

**LIBERIA
CIVIL AVIATION REGULATIONS**



**PART 23.1
AIR NAVIGATION SERVICE**

EDITION 1.0

JULY 13, 2021



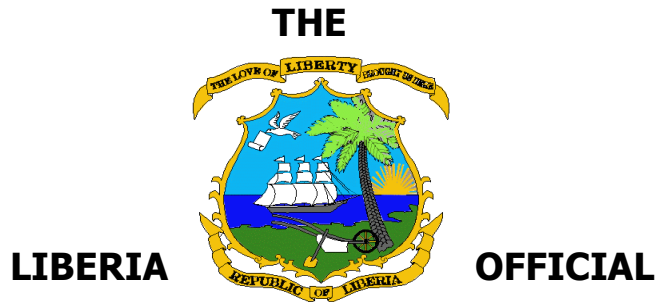

GAZETTE

PUBLISHED BY AUTHORITY

VOL. XXI WEDNESDAY, AUGUST 11, 2021 NO. 46

EXTRAORDINARY

The Government of the Republic of Liberia announces that the Liberia Civil Aviation Authority, pursuant to its mandate under the Liberia Civil Aviation Act of 2019, and specifically consistent with Subchapter XII, Section 1218 (1), has issued on August 11, 2021 its Regulation N0. LCAA/LCAR/001/2021, herein under:

CONCERNING LIBERIA CIVIL AVIATION REGULATIONS

BY ORDER OF THE PRESIDENT

**AMB. DEE-MAXWELL SAAH KEMAYAH, SR.
MINISTER OF FOREIGN AFFAIRS**

**MINISTRY OF FOREIGN AFFAIRS
MONROVIA, LIBERIA**



AUTHORITY TO PROMULGATE CIVIL AVIATION REGULATIONS

IN EXERCISE OF THE POWERS CONFERRED ON THE DIRECTOR GENERAL OF LIBERIA CIVIL AVIATION AUTHORITY UNDER THE LIBERIA CIVIL AVIATION ACT OF 2019 THESE REGULATIONS ARE MADE.

DATE: 13th July 2021



SIGNATURE: _____

Hon. Moses Y. Kollie
DIRECTOR GENERAL

THIS PAGE INTENTIONALLY LEFT BLANK

INTRODUCTION

The following Regulations governing Air Navigation Services (ANS) are based on subchapter IV section 401 of the Liberia Civil Aviation Act of 2006 and in accordance with the following ICAO Annexes: 3, 4, 10, 11, 12, 15 and related ICAO Documents.

The promulgation of this regulation is based on the authority granted in Section 409 of the Civil Aviation Act, and is issued under the authority of the Director General, Liberia Civil Aviation Authority (LCAA), as a duly delegated representative of the LCAA Board of Directors.

The Liberia Civil Aviation Authority is responsible for the preparation and distribution of all regulations and procedures in sufficient quantities so that all service providers and aircraft operators based in Liberia are able to obtain an authentic copy prior to the effective date of the Regulation.

Subpart 1 of this Regulation is a technical document which defines for international aircraft operations and systems necessary to provide radio navigation aids used by aircraft in all phases of flight. The requirements and guidance material of this Subpart list essential parameter specifications for radio navigation aids such as the Global Navigation Satellite System (GNSS), Instrument Landing System (ILS), Microwave Landing System (MLS), Very High Frequency (VHF) Omni-Directional Radio Range (VOR), Non-Directional Radio Beacon (NDB) and Distance Measuring Equipment (DME).

The information contained in Subpart 1 includes aspects of power requirements, frequency, modulation, signal characteristics and monitoring needed to ensure that suitably equipped aircraft will be able to receive navigation signals in all parts of the world with the requisite degree of reliability.

Table of Contents

PART 23.1 —RADIO NAVIGATION AIDS.....	8
23.1.1 DEFINITIONS.....	8
23.1.2 GENERAL PROVISIONS FOR RADIO NAVIGATION AIDS.....	11
23.1.2.1 Standard radio navigation aids.....	11
23.1.2.2 GROUND AND FLIGHT TESTING.....	13
23.1.2.3 PROVISION OF INFORMATION ON THE OPERATIONAL STATUS OF RADIO NAVIGATION AIDS.....	13
23.1.2.4 POWER SUPPLY FOR RADIO NAVIGATION AIDS AND COMMUNICATION SYSTEMS.....	13
23.1.2.5 HUMAN FACTORS CONSIDERATIONS.....	13
23.1.3 SPECIFICATIONS FOR RADIO NAVIGATION AIDS.....	13
23.1.3.1 SPECIFICATION FOR ILS.....	14
23.1.3.2 SPECIFICATION FOR PRECISION APPROACH RADAR SYSTEM.....	36
23.1.3.3 SPECIFICATION FOR VHF OMNIDIRECTIONAL RADIO RANGE (VOR).....	38
23.1.3.4 SPECIFICATION FOR NON-DIRECTIONAL RADIO BEACON (NDB).....	42
23.1.3.5 SPECIFICATION FOR UHF DISTANCE MEASURING EQUIPMENT (DME).....	44
23.1.3.6 SPECIFICATION FOR EN-ROUTE VHF MARKER BEACONS (75MHZ).....	64
23.1.3.7 REQUIREMENTS FOR THE GLOBAL NAVIGATION SATELLITE SYSTEM (GNSS).....	65
23.1.3.8 RESERVED.....	78
23.1.3.9 SYSTEM CHARACTERISTICS OF AIRBORNE ADF RECEIVING.....	78
23.1.3.10 RESERVED.....	78
23.1.3.11 MICROWAVE LANDING SYSTEM (MLS) CHARACTERISTICS.....	79
PART 23.1- IMPLEMENTING STANDARDS.....	116
IS: 23.1.3.7. TECHNICAL SPECIFICATIONS FOR THE GLOBAL NAVIGATION SATELLITE SYSTEM (GNSS).....	116
IS: 23.1.3.11 MICROWAVE LANDING SYSTEM (MLS) CHARACTERISTICS.....	281

PART 23.1 —RADIO NAVIGATION AIDS

**INTERNATIONAL STANDARDS
AND RECOMMENDED PRACTICES**

23.1.1 DEFINITIONS

Note 1. — All references to “Radio Regulations” are to the Radio Regulations published by the International Telecommunication Union (ITU). Radio Regulations are amended from time to time by the decisions embodied in the Final Acts of World Radio communication Conferences held normally every two to three years. Further information on the ITU processes as they relate to aeronautical radio system frequency use is contained in the Handbook on Radio Frequency Spectrum Requirements for Civil Aviation including statement of approved ICAO policies (Doc 9718).

Note 2. — Provisions in this Section of Part 2 are for certain forms of equipment for air navigation aids. While the Republic of LIBERIA will determine the necessity for specific installations in accordance with the conditions prescribed in the relevant Provisions, review of the need for specific installation and the formulation of ICAO opinion and recommendations to Contracting States concerned is carried out periodically by Council, ordinarily on the basis of recommendations of Regional Air Navigation Meetings (Doc 8144 — REGULATIONS to Regional Air Navigation Meetings and Rules of Procedure for their Conduct).

Note 3.— The terminology used in this Annex to refer to instrument approach operations is based on a previous version of the Annex 6 classification of instrument approach and landing operations. It can be mapped to the Annex 6 definitions as follows:

Performance requirements in support of instrument approach operations		
Annex 10 system performance		Annex 6 method — Approach operation category
Non-precision approach (NPA)		2D-Type A ⁽¹⁾
Approach with vertical guidance (APV)		3D-Type A ⁽²⁾
Precision approach (PA)	Category I, DH equal to or greater than 75 m (250 ft)	3D-Type A ⁽³⁾
	Category I, DH equal to or greater than 60 m (200 ft) and less than 75 m (250 ft)	3D-Type B — CAT I ⁽³⁾
	Category II	3D-Type B — CAT II
	Category III	3D-Type B — CAT III

(1) Without vertical guidance.
 (2) With barometric or SBAS vertical guidance.
 (3) With ILS, MLS, GBAS or SBAS vertical guidance.

When the following terms are used in this volume, they have the following meanings:

(a) for the purpose of part 23.1, the following definitions shall apply:

- (1) **Altitude.** The vertical distance of a level, a point or an object considered as a point, measured from mean sea level (MSL).
- (2) **Area navigation (RNAV).** A method of navigation which permits aircraft operation on any desired flight path within the coverage of ground- or space-based navigation aids or within the limits of the capability of self-contained aids, or a combination of these.
Note. — Area navigation includes performance-based navigation as well as other operations that do not meet the definition of performance-based navigation.
- (3) **Effective acceptance bandwidth.** The range of frequencies with respect to the assigned frequency for which reception is assured when all receiver tolerances have been taken into account.
- (4) **Effective adjacent channel rejection.** The rejection that is obtained at the appropriate adjacent channel frequency when all relevant receiver tolerances have been taken into account.
- (5) **Elevation.** The vertical distance of a point or a level, on or affixed to the surface of the earth, measured from mean sea level.
- (6) **Essential radio navigation service.** A radio navigation service whose disruption has a significant impact on operations in the affected airspace or aerodrome.
- (7) **Fan marker beacon.** A type of radio beacon, the emissions of which radiate in a vertical fan-shaped pattern.
- (8) **Height.** The vertical distance of a level, a point or an object considered as a point, measured from a specified datum.
- (9) **Human Factors principles.** Principles which apply to design, certification, training, operations and maintenance and which seek safe interface between the human and other system components by proper consideration to human performance.
Note. — A time of 1/10 second during which the mean power is greatest will be selected normally.
- (10) **Navigation specification.** A set of aircraft and flight crew requirements needed to support performance-based navigation operations within a defined airspace. There are two kinds of navigation specifications:
Required navigation performance (RNP) specification. A navigation specification based on area navigation that includes the requirement for performance monitoring and alerting, designated by the prefix RNP, e.g. RNP 4, RNP APCH.
Area navigation (RNAV) specification. A navigation specification based on area navigation that does not include the requirement for performance monitoring and alerting, designated by the prefix RNAV, e.g. RNAV 5, RNAV 1.
Note. 1— The Performance-based Navigation (PBN) Manual (Doc 9613), Subpart II, contains detailed guidance on navigation specifications.

Note 2. — The term RNP, previously defined as “a statement of the navigation performance necessary for operation within a defined airspace”, has been removed from this Annex as the concept of RNP has been overtaken by the concept of PBN. The term RNP in this Annex is now solely used in the context of navigation specifications that require performance monitoring and alerting, e.g. RNP 4 refers to the aircraft and operating requirements, including a 4 NM lateral performance with on-board performance monitoring and alerting that are detailed in Doc 9613.

- (11) **Mean power (of a radio transmitter).** The average power supplied to the antenna transmission line by a transmitter during an interval of time sufficiently long compared with the lowest frequency encountered in the modulation taken under normal operating conditions.
- (12) **Mean power (of a radio transmitter).** The average power supplied to the antenna transmission line by a transmitter during an interval of time sufficiently long compared with the lowest frequency encountered in the modulation taken under normal operating conditions.

Note. — A time of 1/10 second during which the mean power is greatest will be selected normally.

Note. 1— The Performance-based Navigation (PBN) Manual (Doc 9613), Subpart II, contains detailed guidance on navigation specifications.

Note 2. — The term RNP, previously defined as “a statement of the navigation performance necessary for operation within a defined airspace”, has been removed from this Part as the concept of RNP has been overtaken by the concept of PBN. The term RNP in this Part is now solely used in the context of navigation specifications that require performance monitoring and alerting, e.g. RNP 4 refers to the aircraft and operating requirements, including a 4 NM lateral performance with on-board performance monitoring and alerting that are detailed in Doc 9613.

- (13) **Performance-based navigation (PBN).** Area navigation based on performance requirements for aircraft operating along an ATS route, on an instrument approach procedure or in a designated airspace.

Note.— Performance requirements are expressed in navigation specifications (RNAV specification, RNP specification) in terms of accuracy, integrity, continuity, availability and functionality needed for the proposed operation in the context of a particular airspace concept

- (14) **Pressure-altitude.** An atmospheric pressure expressed in terms of altitude which corresponds to that pressure in the Standard Atmosphere.
- (15) **Protected service subpart.** A part of the facility coverage where the facility provides a particular service in accordance with relevant SARPs and within which the facility is afforded frequency protection.
- (16) **Radio navigation service.** A service providing guidance information or position data for the efficient and safe operation of aircraft supported by one or more radio navigation aids
- (17) **Touchdown.** The point where the nominal glide path intercepts the runway.
- (18) **Z marker beacon.** A type of radio beacon, the emissions of which radiate in a vertical cone-shaped pattern.
- (19) **Elevation.** The vertical distance of a point or a level, on or affixed to the surface of the earth, measured from mean sea level.

- (20) **Essential radio navigation service.** A radio navigation service whose disruption has a significant impact on operations in the affected airspace or aerodrome.
- (21) **Fan marker beacon.** A type of radio beacon, the emissions of which radiate in a vertical fan-shaped pattern.
- (22) **Height.** The vertical distance of a level, a point or an object considered as a point, measured from a specified datum.
- (23) **Human Factors principles.** Principles which apply to design, certification, training, operations and maintenance and which seek safe interface between the human and other system components by proper consideration to human performance.

Note. — A time of 1/10 second during which the mean power is greatest will be selected normally.

- (24) **Navigation specification.** A set of aircraft and flight crew requirements needed to support performance-based navigation operations within a defined airspace. There are two kinds of navigation specifications:

Required navigation performance (RNP) specification. A navigation specification based on area navigation that includes the requirement for performance monitoring and alerting, designated by the prefix RNP, e.g. RNP 4, RNP APCH.

Area navigation (RNAV) specification. A navigation specification based on area navigation that does not include the requirement for performance monitoring and alerting, designated by the prefix RNAV, e.g. RNAV 5, RNAV 1.

Note. 1— The Performance-based Navigation (PBN) Manual (Doc 9613), Subpart II, contains detailed guidance on navigation specifications.

Note 2. — The term RNP, previously defined as “a statement of the navigation performance necessary for operation within a defined airspace”, has been removed from this Annex as the concept of RNP has been overtaken by the concept of PBN. The term RNP in this Annex is now solely used in the context of navigation specifications that require performance monitoring and alerting, e.g. RNP 4 refers to the aircraft and operating requirements, including a 4 NM lateral performance with on-board performance monitoring and alerting that are detailed in Doc 9613.

23.1.2 GENERAL PROVISIONS FOR RADIO NAVIGATION AIDS

23.1.2.1 STANDARD RADIO NAVIGATION AIDS

(a) The standard radio navigation aids shall be:

- (1) the instrument landing system (ILS) conforming to the Standards contained in LCAA part 23.1.3.1
- (2) the microwave landing system (MLS) conforming to the Standards contained in LCAA part 23.1.3.11;
- (3) the global navigation satellite system (GNSS) conforming to the Standards contained in LCAA part 23.1.3.7;

- (4) the VHF omnidirectional radio range (VOR) conforming to the Standards contained in LCAA part 23.1.3.3;
- (5) the non-directional radio beacon (NDB) conforming to the Standards contained in LCAA part 23.1.3.4;
- (6) the distance measuring equipment (DME) conforming to the Standards contained in LCAA part 23.1.3.5; and
- (7) the en-route VHF marker beacon conforming to the Standards contained in LCAA part 23.1.3.6

(b) Differences in radio navigation aids in any respect from the provisions of Subpart 3 shall be published in the Liberia Aeronautical Information Publication (AIP).

(c) Wherever there is installed a radio navigation aid that is neither an ILS nor an MLS, but which may be used in whole or in part with aircraft equipment designed for use with the ILS or MLS, full details of parts that may be so used shall be published in the Liberia Aeronautical Information Publication (AIP).

(d) GNSS-SPECIFIC PROVISIONS

(1) It shall be permissible to terminate a GNSS satellite service provided by one of its elements (23.1.3.7.2) on the basis of at least a six-year advance notice by a service provider.

(2) The Authority having approved a GNSS-based operation shall ensure that GNSS data relevant to those operations are recorded.

Note. — *These recorded data are primarily intended for use in accident and incident investigations. They may also support periodic confirmation that accuracy, integrity, continuity and availability are maintained within the limits required for the operations approved.*

(3) Recordings shall be retained for a period of at least 14 days. When the recordings are pertinent to accident and incident investigations, they shall be retained for longer periods until it is evident that they will no longer be required.

(e) PRECISION APPROACH RADAR

(1) A Precision Approach Radar (PAR) system, where installed and operated as a radio navigation aid together with equipment for two-way communication with aircraft and facilities for the efficient coordination of these elements with air traffic control, shall conform to the provisions contained in 23.1.3.2.

Note 1.— *The precision approach radar (PAR) element of the precision approach radar system may be installed and operated without the surveillance radar element (SRE), when it is*

determined that the SRE is not necessary to meet the requirements of air traffic control for the handling of aircraft.

Note 2. — Although SRE is not considered, in any circumstances, a satisfactory alternative to the precision approach radar system, the SRE may be installed and operated without the PAR for the assistance of air traffic control in handling aircraft intending to use a radio navigation aid, or for surveillance radar approaches and departures.

- (f) When a radio navigation aid is provided to support precision approach and landing, it shall be supplemented, as necessary, by a source or sources of guidance information which, when used in conjunction with appropriate procedures, will provide effective guidance to, and efficient coupling (manual or automatic) with, the desired reference path.

Note. — DME, GNSS, NDB, VOR and aircraft navigation systems have been used for such purposes.

23.1.2.2 GROUND AND FLIGHT TESTING

- (a) Radio navigation aids of the types covered by the specifications in Subpart 23.1.3 and available for use by aircraft engaged in international air navigation shall be the subject of periodic ground and flight tests.

Note. — Guidance on the ground and flight testing of ICAO standard facilities, including the periodicity of the testing, is contained in the Manual on Testing of Radio Navigation Aids (Doc 8071).

23.1.2.3 PROVISION OF INFORMATION ON THE OPERATIONAL STATUS OF RADIO NAVIGATION AIDS

- (a) Aerodrome control towers and units providing approach control service shall be provided with information on the operational status of radio navigation services essential for approach, landing and take-off at the aerodrome(s) with which they are concerned, on a timely basis consistent with the use of the service(s) involved.

23.1.2.4 POWER SUPPLY FOR RADIO NAVIGATION AIDS AND COMMUNICATION SYSTEMS

- (a) Radio navigation aids and ground elements of communication systems of the types specified in Part 23 of these REGULATIONS shall be provided with suitable power supplies and means to ensure continuity of service appropriate to the needs of the service(s) involved.

23.1.2.5 HUMAN FACTORS CONSIDERATIONS

- (a) Human Factors principles shall be observed in the design and certification of radio navigation aids.

Note. — Guidance material on Human Factors principles can be found in the Human Factors Training Manual (Doc 9683) and Circular 249 (Human Factors Digest No. 11 — Human Factors in CNS/ATM Systems).

23.1.3 SPECIFICATIONS FOR RADIO NAVIGATION AIDS

Note. — Specifications concerning the siting and construction of equipment and installations on operational areas aimed at reducing the hazard to aircraft to a minimum are contained in Subpart 1 of Part 13 of the LIBERIA Civil Aviation (Aerodrome) REGULATIONS.

23.1.3.1 SPECIFICATION FOR ILS

(a) DEFINITIONS

- (1) **Angular displacement sensitivity.** The ratio of measured DDM to the corresponding angular displacement from the appropriate reference line.
- (2) **Back course sector.** The course sector which is situated on the opposite side of the localizer from the runway.
- (3) **Course line.** The locus of points nearest to the runway centre line in any horizontal plane at which the DDM is zero.
- (4) **Course sector.** A sector in a horizontal plane containing the course line and limited by the loci of points nearest to the course line at which the DDM is 0.155.
- (5) **DDM — Difference in depth of modulation.** The percentage modulation depth of the larger signal minus the percentage modulation depth of the smaller signal, divided by 100.
- (6) **Displacement sensitivity (localizer).** The ratio of measured DDM to the corresponding lateral displacement from the appropriate reference line.
- (7) **Facility Performance Category I — ILS.** An ILS which provides guidance information from the coverage limit of the ILS to the point at which the localizer course line intersects the ILS glide path at a height of 60 m (200 ft) or less above the horizontal plane containing the threshold.
- (8) **Facility Performance Category II — ILS.** An ILS which provides guidance information from the coverage limit of the ILS to the point at which the localizer course line intersects the ILS glide path at a height of 15 m (50 ft) or less above the horizontal plane containing the threshold.

Note.— This definition is not intended to preclude the use of Facility Performance Category I — ILS below the height of 60 m (200 ft), with visual reference where the quality of the guidance provided permits, and where satisfactory operational procedures have been established.

- (9) **Facility Performance Category III — ILS.** An ILS which, with the aid of ancillary equipment where necessary, provides guidance information from the coverage limit of the facility to, and along, the surface of the runway.
- (10) **Front course sector.** The course sector which is situated on the same side of the localizer as the runway.
- (11) **Half course sector.** The sector in a horizontal plane containing the course line and limited by the loci of points nearest to the course line at which the DDM is 0.0775.
- (12) **Half ILS glide path sector.** The sector in the vertical plane containing the ILS glide path and limited by the loci of points nearest to the glide path at which the DDM is 0.0875

- (13) **ILS continuity of service.** That quality which relates to the rarity of radiated signal interruptions. The level of continuity of service of the localizer or the glide path is expressed in terms of the probability of not losing the radiated guidance signals.
- (14) **ILS glide path.** That locus of points in the vertical plane containing the runway centre line at which the DDM is zero, which, of all such loci, is the closest to the horizontal plane.
- (15) **ILS glide path angle.** The angle between a straight line which represents the mean of the ILS glide path and the horizontal.
- (16) **ILS glide path sector.** The sector in the vertical plane containing the ILS glide path and limited by the loci of points nearest to the glide path at which the DDM is 0.175.
- (17) **ILS integrity.** That quality which relates to the trust which can be placed in the correctness of the information supplied by the facility. The level of integrity of the localizer or the glide path is expressed in terms of the probability of not radiating false guidance signals.
- (18) **ILS Point “A”** A point on the ILS glide path measured along the extended runway centre line in the approach direction a distance of 7.5 km (4 NM) from the threshold.
- (19) **ILS Point ‘B’.** A point on the ILS glide path measured along the extended runway centre line in the approach direction a distance of 1 050 m (3500ft) from the threshold.
- (20) **ILS Point “C”.** A point through which the downward extended straight portion of the nominal ILS glide path passes at a height of 30 m (100 ft.) above the horizontal plane containing the threshold.
- (21) **ILS Point “D”** A point 4 m (12 ft.) above the runway centre line and 900 m (3 000 ft.) from the threshold in the direction of the localizer.
- (22) **ILS Point “E”.** A point 4 m (12 ft.) above the runway centre line and 600m (2 000 ft.) from the stop end of the runway in the direction of the threshold.
- (23) **ILS reference datum (Point “T”).** A point at a specified height located above the intersection of the runway centre line and the threshold and through which the downward extended straight portion of the ILS glide path passes.
- (24) **Two-frequency glide path system.** An ILS glide path in which coverage is achieved by the use of two independent radiation field patterns spaced on separate carrier frequencies within the particular glide path channel.
- (25) **Two-frequency localizer system.** A localizer system in which coverage is achieved by the use of two independent radiation field patterns spaced on separate carrier frequencies within the particular localizer VHF channel.

(b) BASIC REQUIREMENTS

- (1) The ILS shall comprise the following basic components:
 - i) VHF localizer equipment, associated monitor system, remote control and indicator equipment;

- ii) UHF glide path equipment, associated monitor system, remote control and indicator equipment;
 - iii) VHF marker beacons, associated monitor systems, remote control and indicator equipment, except as provided in (8) below.
- (2) Distance to threshold information to enable glide path verification checks shall be provided by either VHF marker beacons or distance measuring equipment (DME), together with associated monitor systems and remote control and indicator equipment.
- (3) If one or more VHF marker beacons are used to provide distance to threshold information, the equipment shall conform to the specifications in 23.1.3 (n). If DME is used in lieu of marker beacons, the equipment shall conform to the specifications in (9).
- (4) Facility Performance Categories I, II and III — ILS shall provide indications at designated remote control points of the operational status of all ILS ground system components, as follows:
- i) for all Category II and Category III ILS, the air traffic services unit involved in the control of aircraft on the final approach shall be one of the designated remote control points and shall receive information on the operational status of the ILS, with a delay commensurate with the requirements of the operational environment;
 - ii) for a Category I ILS, if that ILS provides an essential radio navigation service, the air traffic services unit involved in the control of aircraft on the final approach shall be one of the designated remote control points and shall receive information on the operational status of the ILS, with a delay commensurate with the requirements of the operational environment.

Note 1. — The indications required by this Part are intended as a tool to support air traffic management functions, and the applicable timeliness requirements are sized accordingly (consistently with 23.1.2). Timeliness requirements applicable to the ILS integrity monitoring functions that protect aircraft from ILS malfunctions are specified in 23.1.3.1 (c) (11) (iii) (A) and 23.1.3.1 (e) (7) (iii) (A).

Note 2.— It is intended that the air traffic system is likely to call for additional provisions which may be found essential for the attainment of full operational Category III capability, e.g. to provide additional lateral and longitudinal guidance during the landing roll-out, and taxiing, and to ensure enhancement of the integrity and reliability of the system.

- (5) The ILS shall be constructed and adjusted so that, at a specified distance from the threshold, similar instrumental indications in the aircraft represent similar displacements from the course line or ILS glide path as appropriate, irrespective of the particular ground installation in use.
- (6) For Facility Performance Category II and III localizers and glide paths, the level of integrity and continuity of service shall be at least Level 3, as defined in 3.1.3.12.4 (localizer) and 3.1.5.8.4 (glide path).

Note.— The specifications for Facility Performance Categories II and III — ILS are intended to achieve the highest degree of system integrity, reliability and stability of operation under

the most adverse environmental conditions to be encountered. Guidance material to achieve this objective is given in 2.8 of Attachment C.

- (7) The localizer and glide path components specified in 23.1.3.1.2.1 (a and b) above which form part of a Facility Performance Category II — ILS shall comply with the Provisions applicable to these components in a Facility Performance Category I — ILS, as supplemented or amended by the Provisions in 23.1.3.1 (c) and 23.1.3.1 (e) below in which application to Facility Performance Category II — ILS is prescribed.
- (8) The localizer and glide path components and other ancillary equipment specified in 23.1.3.1 (b) (1) (i) above, which form part of a Facility Performance Category III — ILS, shall otherwise comply with the Provisions applicable to these components in Facility Performance Categories I and II ILS, except as supplemented by the Provisions in 23.1.3.1 (c) and 23.1.3.1 (e) below in which application to Facility Performance Category III — ILS is prescribed.
- (9) To ensure an adequate level of safety, the ILS shall be so designed and maintained that the probability of operation within the performance requirements specified is of a high value, consistent with the category of operational performance concerned.
- (10) At those locations where two separate ILS facilities serve opposite ends of a single runway, an interlock shall ensure that only the localizer serving the approach direction in use shall radiate, except where the localizer in operational use is Facility Performance Category I — ILS and no operationally harmful interference results.
- (11) At those locations where two separate ILS facilities serve opposite ends of a single runway and where a Facility Performance Category I— ILS is to be used for auto-coupled approaches and landings in visual conditions an interlock shall ensure that only the localizer serving the approach direction in use radiates, providing the other localizer is not required for simultaneous operational use.
- (12) At locations where ILS facilities serving opposite ends of the same runway or different runways at the same airport use the same paired frequencies, an interlock shall ensure that only one facility shall radiate at a time. When switching from one ILS facility to another, radiation from both shall be suppressed for not less than 20 seconds.

(c) VHF LOCALIZER AND ASSOCIATED MONITOR

The specifications of this 23.1.3.1 (c) cover ILS localizers providing either positive guidance information over 360 degrees of azimuth or providing such guidance only within a specified portion of the front coverage. Where ILS localizers providing positive guidance information in a limited sector are installed, information from some suitably located navigation aid, together with appropriate procedures, will generally be required to ensure that any misleading guidance information outside the sector is not operationally significant.

(1) GENERAL

- i) The radiation from the localizer antenna system shall produce a composite field pattern which is amplitude modulated by a 90 Hz and a 150 Hz tone. The radiation

field pattern shall produce a course sector with one tone predominating on one side of the course and with the other tone predominating on the opposite side.

- ii) When an observer faces the localizer from the approach end of a runway, the depth of modulation of the radio frequency carrier due to the 150 Hz tone shall predominate on his right hand and that due to the 90 Hz tone shall predominate on his left hand.
- iii) All horizontal angles employed in specifying the localizer field patterns shall originate from the centre of the localizer antenna systems which provides the signal used in the front course sector.

(2) RADIO FREQUENCY

- i) The localizer shall operate in the band 108 MHz to 111.975 MHz. Where a single radio frequency carrier is used, the frequency tolerance shall not exceed plus or minus 0.005 per cent. Where two radio frequency carriers are used, the frequency tolerance shall not exceed 0,002 per cent and the nominal band occupied by the carriers shall be symmetrical about the assigned frequency. With all tolerances applied, the frequency separation between the carriers shall not be less than 5 kHz nor more than 14 kHz.
- ii) The emission from the localizer shall be horizontally polarized. The vertically polarized component of the radiation on the course line shall not exceed that which corresponds to a DDM error of 0.0 23 when an aircraft is positioned on the course line and is in a roll attitude of 20 degrees from the horizontal.
 - A. For Facility Performance Category II localizers, the vertically polarized component of the radiation on the course line shall not exceed that which corresponds to a DDM error of 0.008 when an aircraft is positioned on the course line and is in a roll attitude of 20 degrees from the horizontal.
 - B. For Facility Performance Category III localizers, the vertically polarized component of the radiation within a sector bounded by 0.02 DDM either side of the course line shall not exceed that which corresponds to a DDM error of 0.005 when an aircraft is in a roll attitude of 20 degrees from the horizontal.
- iii) For Facility Performance Category III localizers, signals emanating from the transmitter shall contain no components which result in an apparent course line fluctuation of more than 0.005 DDM peak to peak in the frequency band 0.01 Hz to 10 Hz.

(3) COVERAGE

- i) The localizer shall provide signals sufficient to allow satisfactory operation of a typical aircraft installation within the localizer and glide path coverage Sectors. The localizer coverage sector shall extend from the centre of the localizer antenna system to distances of 46.3 km (25 NM) within plus or minus 10 degrees from the front course line; 31.5 km (17 NM) between 10 degrees and 35 degrees from the front course line; 18.5 km (10 NM) outside of plus or minus 35 degrees if coverage is provided; except that, where topographical features dictate or operational requirements permit, the limits may be reduced to 33.3 km (18 NM) within the plus or minus 10-degree sector and 18.5 km (10 NM) within the remainder of the coverage when alternative navigational facilities provide satisfactory coverage

within the intermediate approach area. The localizer signals shall be receivable at the distances specified at and above a height of 600m (2 000 ft.) above the elevation of the threshold, or 300 m (1 000ft.) above the elevation of the highest point within the intermediate and final approach areas, whichever is the higher. Such signals shall be receivable, to the distances specified, up to a surface extending outward from the Localizer antenna and inclined at 7 degrees above the horizontal.

- ii) In all parts of the coverage subpart above, other than as specified in 23.1.3.1 (c) (3) (ii) (A), 23.1.3.1 (c) (3) (ii) (B) and 23.1.3.1 (c) (3) (ii) (C) below, the field strength shall be not less than 40 microvolts per metre (minus 114 dBW/m²),
 - A. For Facility Performance Category I localizers, the minimum field strength on the ILS glide path and within the localizer course sector from a distance of 18.5 km (10 NM) to a height of 60 m (200ft.) above the horizontal plane containing the threshold shall be not less than 90 microvolts its per metre (minus 107 dBW/m²).
 - B. For Facility Performance Category II localizers, the minimum field strength on the ILS glide path and within the localizer course sector shall be not less than 100 microvolts per metre (minus 106 dBW/m²) at a distance of 18.5 km (10 NM) increasing to not less than 200 microvolts per metre (minus 100dBWm²) at a height of 15 m (50 ft) above the horizontal plane containing the threshold.
 - C. For Facility Performance Category III localizers, the minimum field strength on the ILS glide path and within the localizer course sector shall be not less than 100 microvolts per metre (minus 106 dBW/m²) at a distance of 18.5 km (10 NM), increasing to not less than 200 microvolts per metre (minus 100 dBW/m²) at 6 in (20 ft) above the horizontal plane containing the threshold. From this point to a further point 4 m (12 ft) above the runway centre line, and 300 in (1 000 ft) from the threshold in the direction of the localizer, and thereafter at a height of 4 m (12 ft) along the length of the runway in the direction of the localizer, the field strength shall be not less than 100 microvolts per metre (minus 106 dBW/m²).

Note. — The field strengths given in 23.1.3.1 (c) (3) (ii) (B) and 23.1.3.1 (c) (3) (ii) (C) are necessary to provide the signal-to-noise ratiorequired for improved integrity.

- iii) Above 7 degrees, the signals shall be reduced to as low a value as practicable.
- iv) When coverage is achieved by a localizer using two radio frequency carriers, one carrier providing a radiation field pattern in the front course sector and the other providing a radiation field pattern outside that sector, the ratio of the two carrier signal strengths in space within the front course sector to the coverage limits specified at 23.1.3.1 (c) (3) (ii) (A)above shall not be less than 10dB.
- v) For Facility Performance Category III Localizers, the ratio of the two carrier signal strengths in space within the front course sector shall not be less than 23dB.

(4) COURSE STRUCTURE

- i) For Facility Performance Category I localizers, bends in the course line shall not have amplitudes which exceed the following:

: (DDM)
ability)

of coverage to
1”

1” to
3”

oint “A”
g at a
e to
LS

“B” to
“C”

- ii) For Facility Performance Categories II and III localizers, bends in the course line shall not have amplitudes which exceed the following:

(95% probability)

limit of coverage to
int “A”

0.031

int “A” to
int “B”

0.031 at ILS Point “A”
decreasing at a linear rate to
0.005 at ILS Point “B”

int “B” to the
reference datum

0.005

Category III only:

reference datum to
int “D”

0.005

int “D” to
int “E”

0.005 at ILS Point “D”
increasing at a linear rate to
0.010 at ILS Point “E”

(5) CARRIER MODULATION

- i) The nominal depth of modulation of the radio frequency carrier due to each of the 90 Hz and 150 Hz tones shall be 20 per cent along the course line.

- ii) The depth of modulation of the radio frequency carrier due to each of the 90 Hz and 150 Hz tones shall be within the limits of 18 and 22 per cent.
- iii) The following tolerances shall be applied to the frequencies of the modulating tones:
 - A. the modulating tones shall be 90 Hz and 150 Hz within plus or minus 2.5 per cent;
 - B. the modulating tones shall be 90 Hz and 150 Hz within plus or minus 1.5 per cent for Facility Performance Category II installations;
 - C. the modulating tones shall be 90 Hz and 150 Hz within plus or minus 1 per cent for Facility Performance Category III installations;
 - D. the total harmonic content of the 90 Hz tone shall not exceed 10 per cent; additionally, for Facility Performance Category III localizers, the second harmonic of the 90 Hz tone shall not exceed 5 per cent;
 - E. the total harmonic content of the 150 Hz tone shall not exceed 10 per cent.
 - F. For Facility Performance Category I — ILS, the modulating tones shall be 90Hz and 150 Hz within plus or minus 1.5 per cent where practicable.
 - G. For Facility Performance Category III localizers, the depth of amplitude modulation of the radio frequency carrier at the power supply frequency or its harmonics, or by other unwanted components, shall not exceed 0.5 percent. Harmonics of the supply, or other unwanted noise components that may intermodulate with the 90 Hz and 150 Hz navigational tones or their harmonics to produce fluctuations in the course line, shall not exceed 0.05 per cent modulation depth of the radio frequency carrier.
 - H. The modulation tones shall be phase-locked so that within the half course sector, the demodulated 90 Hz and 150 Hz wave forms pass through zero in the same direction within:
 - I. for Facility Performance Categories I and II localizers: 20 degrees; and
 - J. for Facility Performance Category III localizers: 10 degrees, of phase relative to the 150 Hz component, every half cycle of the combined 90 Hz and 150 Hz wave form.
- iv) With two-frequency localizer systems, (f) above shall apply to each carrier. In addition, the 90 Hz modulating tone of one carrier shall be phase-locked to the 90 Hz modulating tone of the other carrier so that the demodulated wave forms pass through zero in the same direction within:
 - A. for Categories I and II localizers: 20 degrees; and
 - B. for Category III localizers: 10 degrees, of phase relative to 90 Hz. Similarly, the 150 Hz tones of the two carriers shall be phase-locked so that the demodulated wave forms pass through zero in the same direction within:
 - C. for Categories I and II localizers: 20 degrees; and
 - D. for Category III localizers: 10 degrees, of phase relative to 150 Hz.
- v) Alternative two-frequency localizer systems that employ audio phasing different from the normal inphase conditions described in 23.1.3.1 (c) (5) (iii) (D) above shall be permitted. In this alternative system, the 90 Hz to 90 Hz phasing and the 150 Hz to

150 Hz ph asing shall be adjusted to their nominal values to within limits equivalent to those stated in 23.1.3.1 (c) (5) (iii) (D) above.

- vi) The sum of the modulation depths of the radio frequency carrier due to the 90 Hz and 150 Hz tones shall not exceed 60 per cent or be less than 30 per cent within the required coverage.
 - A. For equipment first installed after 1 January 2000, the sum of the modulation depths of the radio frequency carrier due to the 90 Hz and 150 Hz tones shall not exceed 60 percent or be less than 30 per cent within the required coverage.

Note 1.— If the sum of the modulation depths is greater than 60 per cent for Facility Performance Category I localizers, the nominal displacement sensitivity may be adjusted as provided for in 23.1.3.1 (c) (7) (i) to achieve the above modulation limit.

Note 2.— For two-frequency systems, the standard for maximum sum of modulation depths does not apply at or near azimuths where the course and clearance carrier signal levels are equal in amplitude (i.e. at azimuths where both transmitting systems have a significant contribution to the total modulation depth).

- vii) When utilizing a localizer for radiotelephone communications, the sum of the modulation depths of the radio frequency carrier due to the 90 Hz and 150 Hz tones shall not exceed 65 per cent within 10 degrees of the course line and shall not exceed 78 per cent at any other point around the localizer.
- viii) Undesired frequency and phase modulation on ILS localizer radio frequency carriers that can affect the displayed DDM values in localizer receivers shall be minimized to the extent practical.

(6) COURSE ALIGNMENT ACCURACY

- i) The mean course line shall be adjusted and maintained within limits equivalent to the following displacements from the runway centre line at the ILS reference datum:
 - A. for Facility Performance Category I localizers: plus or minus 10.5 m (35 ft), or the linear equivalent of 0.015 DDM, whichever is less;
 - B. for Facility Performance Category II localizers: plus or minus 7.5 m (25 ft.);
 - C. for Facility Performance Category III localizers: plus or minus 3 m (10 ft.).
- ii) For Facility Performance Category II localizers, the mean course line shall be adjusted and maintained within limits equivalent to plus or minus 4.5 m (15 ft) displacement from runway centre line at the ILS reference datum.

(7) DISPLACEMENT SENSITIVITY

- i) The nominal displacement sensitivity within the half course sector at the ILS reference datum shall be 0.00145 DDM/m (0.00044 DDM/ft.) except that for Category I localizers, where the specified nominal displacement sensitivity cannot be met, the displacement sensitivity shall be adjusted as near as possible to that value. For Facility Performance Category I localizer on runway codes 1 and 2, the nominal displacement sensitivity shall be achieved at the ILS Point “B”. The maximum course sector angle shall not exceed 6 degrees.
- ii) The lateral displacement sensitivity shall be adjusted and maintained within the limits of plus or minus:
 - A. 17 per cent of the nominal value for Facility Performance Categories I and II;

modulation is approximately 9:1 (see 23.1. 3.1 (c) (8) (iii) (B) above), The emissions carrying the identification signal shall be horizontally polarized. Where two carriers are modulated with identification signals, the relative phase of the modulations shall be such as to avoid the occurrence of nulls within the coverage of the localizer.

- iii) The identification signal shall employ the International Morse Code and consist of two or three letters. It may be preceded by the International Morse Code signal of the letter “I”, followed by a short pause where it is necessary to distinguish the ILS facility from other navigational facilities in the immediate area.
 - iv) The identification signal shall be transmitted by dots and dashes at a speed corresponding to approximately seven words per minute, and shall be repeated at approximately equal intervals, not less than six times per minute, at all times during which the localizer is available for operational use, When the transmissions of the localizer are not available for operational use, as, for example, after removal of navigational components, or during maintenance or test transmissions, the identification signal shall be suppressed. The dots shall have a duration of 0.1 second. The dash duration shall be typically three times the duration of the dots. The interval between dots and/or dashes shall be equal to that of one dot plus or minus 10 percent. The interval between letters shall not be less than a duration of the three dots.
- (10) SITING
- i) For Facility Performance Categories II and III, the localizer antenna system shall be located on the extension on the centre line of the runway at the stop end, and the equipment shall be adjusted so that the course lines will be in a vertical plane containing the centre line of the runway served. The antenna height and location shall be consistent with safe obstruction clearance practices.
 - ii) For Facility Performance Category I, the localizer antenna system shall be located and adjusted as in 23.1. 3.1 (c) (10) (i), unless site constraints dictate that the antenna be offset from the centre line of the runway.
 - A. The offset localizer system shall be located and adjusted in accordance with the offset ILS provisions of the Procedures for Air Navigation Services — Aircraft Operations (PANS-OPS) (Doc 8238), Subpart II, and the localizer provisions shall be referenced to the associated fictitious threshold point.
- (11) MONITORING
- i) The automatic monitor system shall provide a warning to the designated control points and cause one of the following to occur, within the period specified in 23.1. 3.1 (c) (11) (iii) (A) below, if any of the conditions stated in 23.1. 3.1 (c) (11) (ii) below persists:
 - A. radiation to cease;
 - B. removal of the navigation and identification components from the carrier;
 - ii) The conditions requiring initiation of monitor action shall be the following:
 - A. for Facility Performance Category I localizers, a shift of the mean course line from the runway centre line equivalent to more than 10.5 m (35 ft), or the linear equivalent to 0,015 DDM, whichever is less, at the ILS reference datum;
 - B. for Facility Performance Category II localizers, a shift of the mean course line from the runway centre line equivalent to more than 7.5 m (25 ft.) at the ILS reference datum;
 - C. for Facility Performance Category III localizers, a shift of the mean course line from the runway centre line equivalent to more than 6 m (20 ft.) at the ILS reference datum;

- D. in the case of localizers in which the basic functions are provided by the use of a single-frequency system, a reduction of power output to less than 50 per cent of normal, provided the localizer continues to meet the requirements of 23.1.3.1(c) (3), 23.1.3.1(c) (4) and 23.1.3.1(c) (5) above;
- E. in the case of localizers in which the basic functions are provided by the use of a two-frequency system, a reduction of power output for either carrier to less than 80 per cent of normal, except that a greater reduction to between 80 per cent and 50 per cent of normal may be permitted, provided the localizer continues to meet the requirements of 23.1.3.1(c) (3), 23.1.3.1(c) (4) and 23.1.3.1(c) (5) above;

Note. — It is important to recognize that a frequency change resulting in a loss of the frequency difference specified in 23.1.3.1(c) (2) (i) may produce a hazardous condition. This problem is of greater operational significance for Categories II and III installations. As necessary, this problem can be dealt with through special monitoring provisions or highly reliable circuitry.

- F. change of displacement sensitivity to a value differing by more than 17 per cent from the nominal value for the localizer facility.
 - G. In the case of localizers in which the basic functions are provided by the use of a two-frequency system, the conditions requiring initiation of monitor action shall include the case when the DDM in the required coverage beyond plus or, minus 10 degrees from the front course line, except in the back course sector decreases below 0.155
- iii) The total period of radiation, including period(s) of zero radiation, outside the performance limits specified in 23.1.3.1 (c) (11) (ii) above shall be as short as practicable, consistent with the need for avoiding interruptions of the navigation service provided by the localizer.
- A. The total period referred to under 23.1.3.1 (c) (11) (iii) shall not exceed under any circumstances:
 - 10 seconds for Category I localizers;
 - 5 seconds for Category II localizers;
 - 2 seconds for Category III localizers.
 - B. Where practicable, the total period under 23.1.3.1 (c) (11) (iii) (A) shall be reduced so as not to exceed two seconds for Category II localizers and one second for category III localizers.
- iv) Design and operation of the monitor system shall be consistent with the requirement that navigation guidance and identification will be removed and a warning provided at the designated remote control points in the event of failure of the monitor system itself.

(12) INTEGRITY AND CONTINUITY OF SERVICE REQUIREMENTS

- i) The probability of not radiating false guidance signals shall not be less than $1-0.5 \times 10^{-9}$ in any one landing for facility performance Categories II and III localizers.

- ii) The probability of not radiating false guidance signals shall not be less than $1 - 1.0 \times 10^{-7}$ in any one landing for facility performance category I localizers.
- iii) The probability of not losing the radiated guidance signal shall be greater than:
 - A. $1 - 2 \times 10^{-6}$ in any period of 15 seconds for Facility performance Category II localizers or localizers intended to be used for Category III A operations (equivalent to 2000 hours mean time between outages); and
 - B. $1 - 2 \times 10^{-6}$ in any period of 30 seconds for Facility performance Category III localizers intended to be used for the full range of Category III operations (equivalent to 4000 hours mean time between outages).
- iv) The probability of not losing the radiated guidance signal shall exceed $1 - 4 \times 10^{-6}$ in any period of 15 seconds for facility performance Category I localizers (equivalent to 1 000 hours mean time between outages).

(D) INTERFERENCE IMMUNITY PERFORMANCE FOR ILS LOCALIZER RECEIVING SYSTEMS

- (1) The ILS localizer receiving system shall provide adequate immunity to interference from two-signal, third-order intermodulation products caused by VHF FM broadcast signals having levels in accordance with the following:

$$2N_1 + N_2 + 72 \leq 0$$

for VHF FM sound broadcasting signals in the range 107.7— 108.0 MHz

and

$$2N_1 + N_2 + 3(24 - 20 \log \Delta f / 0.4) \leq 0$$

for VHF FM sound broadcasting signals below 107.7 MHz,

where the frequencies of the two VHF FM sound broadcasting signals produce, within the receiver, a two-signal, third-order intermodulation product on the desired ILS localizer frequency.

N_1 and N_2 are the levels (dBm) of the two VHF FM sound broadcasting signals at the ILS localizer receiver input. Neither level shall exceed the desensitization criteria set forth in 23.1.3.1 (d) (ii).

$\Delta f = 108.1 - f_1$, where f_1 is the frequency of N_1 , the VHF FM sound broadcasting signal closer to 108.1 MHz.

- (2) The ILS localizer receiving system shall not be desensitized in the presence of VHF FM broadcast signals having levels in accordance with the following table:

Frequency (MHz)	Maximum level of unwanted signal at receiver input (dBm)
88-102	+15
104	+10
106	+5
107.9	-10

(e) **UHF GLIDE PATH EQUIPMENT AND ASSOCIATED MONITOR**

(1) **General**

- i) The radiation from the UHF glide path antenna system shall produce a composite field pattern which is amplitude modulated by a 90 Hz and a 150 Hz tone. The pattern shall be arranged to provide a straight line descent path in the vertical plane containing the centre line of the runway, with the 150 Hz tone predominating below the path and the 90 Hz tone predominating above the path to at least an angle equal to 1.75 θ
- (2) The ILS glide path angle shall be 3 degrees. ILS glide path angles in excess of 3 degrees shall not be used except where alternative means of satisfying obstruction clearance requirements are impracticable.
- i) The glide path angle shall be adjusted and maintained within:
- A. 0.075 θ from θ for Facility Performance Categories I and II — ILS glide paths;
 - B. 0.04 θ from θ for Facility Performance Category III — ILS glides paths.
- (3) The downward extended straight portion of the ILS glide path shall pass through the ILS reference datum at a height ensuring safe guidance over obstructions and also safe and efficient use of the runway served.
- (4) The height of the U.S reference datum for Facility Performance Categories II and III — ILS shall be 15 m (50 ft). A tolerance of plus 3 m (10 ft) is permitted.
- (5) The height of the ILS reference datum for Facility Performance Category I -ILS shall be 15 m (50 ft). A tolerance of plus 3 m (10 ft) is permitted.
- (6) The height of the ILS reference datum for Facility Performance Category I —ILS used on short precision approach runway codes 1 and 2 shall be 12 m (40 ft). A tolerance of plus 6 m (20 ft) is permitted.

(f) **RADIO FREQUENCY**

- (1) The glide path equipment shall operate in the band 328.6 MHz to 335.4 MHz. Where a single radio frequency carrier is used, the frequency tolerance shall not exceed 0.005 per cent. Where two carrier glide path systems are used, the frequency tolerance shall not exceed 0.002 per cent and the nominal band occupied by the carriers shall be symmetrical about the assigned frequency. With all tolerances applied, the frequency separation between the carriers shall not be less than 4 kHz nor more than 32 kHz.
- (2) The emission from the glide path equipment shall be horizontally polarized.
- (3) For Facility Performance Category III — ILS glide path equipment, signals emanating from the transmitter shall contain no components which result in apparent glide path fluctuations of more than 0.02 DDM peak to peak in the frequency band 0.01 Hz to 10 Hz.

(g) **COVERAGE**

- (1) The glide path equipment shall provide signals sufficient to allow satisfactory operation of a typical aircraft installation in sectors of 8 degrees in azimuth on each side of the centre line of the ILS glide path, to a distance of at least 18.5 km (10 NM) up to 1.75 θ and down to 0.45 θ above the horizontal or to such lower angle, down to 0.30 θ , as required to safeguard the promulgated glide path intercept procedure.
- (2) In order to provide the coverage for glide path performance specified in 23.1.3.1 (e) (3) (i) above, the minimum field strength within this coverage sector shall be 400 microvolts per

metre (minus 95 dBW/m²). For Facility Performance Category I glide paths, this field strength shall be provided down to a height of 30 m (100 ft) above the horizontal plane containing the threshold. For Facility Performance Categories II and ILS glide paths, this field strength shall be provided down to a height of 15 m (50 ft) above the horizontal plane containing the threshold.

(h) ILS GLIDE PATH STRUCTURE

- (1) For Facility Performance Category I — ILS glide paths, bends in the glide path shall not have amplitudes which exceed the following

Zone	Amplitude (DDM) (95% probability)
Outer limit of coverage To ILS Point “C”	0.035

- (2) For Facility Performance Categories II and III — ILS glide paths, bends in the glide path shall not have amplitudes which exceed the following:

Zone	Amplitude (DDM) (95% probability)
Outer limit of coverage To ILS Point “A”	0.035
ILS Point “A” To ILS Point “B”	0.035 at ILS Point “A” decreasing at linear rate To 0.023 at ILS Point “B”
ILS Point “B” to the ILS reference datum	0.023.

Note 1.— The amplitudes referred to in 3.1.5.4.1 and 3.1.5.4.2 are the DDMs due to bends as realized on the mean ILS glide path correctly adjusted.

Note 2.— In regions of the approach where ILS glide path curvature is significant, bend amplitudes are calculated from the mean curved path, and not the downward extended straight line.

Note 3.— Guidance material relevant to the ILS glide path course structure is given in 2.1.4 of Attachment C.

(i) CARRIER MODULATION

- (1) The nominal depth of modulation of the radio frequency carrier due to each of the 90 Hz and 150 Hz tones shall be 40 per cent along the ILS glide path. The depth of modulation shall not deviate outside the limits of 37.5 per cent to 42.5 per cent.

- (2) The following tolerances shall be applied to the frequencies of the modulating tones:
- i) the modulating tones shall be 90 Hz and 150 Hz within 2.5 per Cent for Facility Performance Category I — ILS:
 - A. the modulating tones shall be 90 Hz and 150 Hz within 1.5 per cent for Facility performance Category II — ILS;
 - B. the modulating tones shall be 90 Hz and 150 Hz within 1 per cent for Facility Performance Category III — ILS;

- C. the total harmonic content of the 90 Hz tone shall not exceed 10 per cent; additionally, for Facility Performance Category III equipment, the second harmonic of the 90 Hz tone shall not exceed 5 per cent;
 - D. the total harmonic content of the 150 Hz tone shall not exceed 10 percent.
- ii) For Facility Performance Category I — ILS, the modulating tones shall be 90 Hz and 150 Hz within plus or minus 1.5 percent where practicable.
 - iii) For Facility Performance Category III glide path equipment, the depth of amplitude modulation of the radio frequency carrier at the power supply frequency or harmonics, or at other noise frequencies, shall not exceed 1 per cent.
- (3) The modulation shall be phase locked so that within the ILS half glide path sector, the demodulated 90 Hz and 150 Hz wave forms pass through zero in the same direction within:
- i) for Facility Performance Categories I and II — ILS glide paths: 20 degrees;
 - ii) for Facility Performance Category III ILS glide paths: 10 degrees, of phase relative to the 150 Hz component, every half cycle of the combined 90 Hz and 150 Hz wave form.
- iii) With two-frequency glide path systems, 23.1. 3.1.5.5.3 above shall apply to each carrier. In addition, the 90 Hz modulating tone of one carrier shall be phase-locked to the 90 Hz modulating tone of the other carrier so that the demodulated wave forms pass through zero in the same direction within:
 - A. for Categories I and II — ILS glide paths: 20 degrees;
 - B. for Category III — ILS glide paths: 10 degrees, of phase relative to 90 Hz. Similarly, the 150 Hz tones of the two carriers shall be phase-locked so that the demodulated wave forms pass through zero in the same direction, within:
 - C. for Categories I and II — ILS glide paths: 20 degrees;
 - D. for Category III — ILS glide paths: 10 degrees, of phase relative to 150 Hz.
 - iv) Alternative two-frequency glide path systems that employ audio phasing different from the normal in-phase condition described in 23.1.3.1 (e) (5) (iii) (A) above shall be permitted. In these alternative systems, the 90 Hz to 90 Hz phasing and the 150 Hz to 150 Hz phasing shall be adjusted to their nominal values to within limits equivalent to those stated in 23.1.3.1 (e) (5) (iii) (A) above.
 - v) Undesired frequency and phase modulation on ILS glide path radio frequency carriers that can affect the displayed DDM values in glide path receivers shall be minimized to the extent practical.

(j) DISPLACEMENT SENSITIVITY

- (1) For Facility Performance Category I — ILS glide paths, the nominal angular displacement sensitivity shall correspond to a DDM of 0.0875 at angular displacements above and below the glide path between 0.07θ and 0.14θ .
- (2) For Facility Performance Category I — ILS glide paths, the nominal angular displacement sensitivity shall correspond to a DDM of 0.0875 at an angular displacement below the glide path of 0.12θ with a tolerance of plus or minus 0.02θ . The upper and lower sectors shall be as symmetrical as practicable within the limits specified in 23.1.3(a) above.
- (3) For Facility Performance Category II — ILS glide paths, the angular displacement sensitivity shall be as symmetrical as practicable. The nominal angular displacement sensitivity shall correspond to a DDM of 0.0875 at an angular displacement of:
 - i) 0.12θ below path with a tolerance of plus or minus 0.02θ ;

- ii) 0.12 θ above path with a tolerance of plus 0.02 θ and minus 0.05 θ .
- (4) For Facility Performance Category III— ILS glide paths, the nominal angular displacement sensitivity shall correspond to a DDM of 0.0875 at angular displacements above and below the glide path of 0.12 θ with a tolerance of plus or minus 0.02 θ .
- (5) The DDM below the ILS glide path shall increase smoothly for decreasing angle until a value of 0.22 DDM is reached. This value shall be achieved at an angle not less than 0.30 θ above the horizontal. However, if it is achieved at an angle above 0.45 θ , the DDM value shall not less than 0.22 at least down to 0.45 θ or to such lower angle, down to 0.30 θ , as required to safeguard the promulgated glide path intercept procedure.
- (6) For Facility Performance Category I — ILS glide paths, the angular displacement sensitivity shall be adjusted and maintained within plus or minus 25 per cent of the nominal value selected.
- (7) For Facility Performance Category II — ILS glide paths, the angular displacement sensitivity shall be adjusted and maintained within plus or minus 20 per cent of the nominal value selected.
- (8) For Facility Performance Category III — ILS glide paths, the angular displacement sensitivity shall be adjusted and maintained within plus or minus 15 per cent of the nominal value selected.

(k) MONITORING

- (1) The automatic monitor system shall provide a warning to the designated control points and cause radiation to cease within the periods specified in 23.1.3.1 (e) (7) (iii) (A) if any of the following conditions persist:
 - i) shift of the mean ILS glide path angle equivalent to more than minus 0.075 θ to plus 0.10 θ from θ ;
 - ii) in the case of ILS glide paths in which the basic functions are provided by the use of a single-frequency system, a reduction of power output to less than 50 per cent of normal, provided the glide path continues to meet the requirements of 23.1.3.1 (e) (3), 23.1.3.1 (e) (4) and 23.1.3.1 (e) (5);
 - iii) in the case of ILS glide paths in which the basic functions are provided by the use of two-frequency systems, a reduction of power output for either carrier to less than 80 per cent of normal, except that a greater reduction to between 80 per cent and 50 per cent of normal may be permitted, provided the glide path continues to meet the requirements of 23.1.3.1 (e) (3), 23.1.3.1 (e) (4) and 23.1.3.1 (e) (5); for Facility Performance Category I — ILS glide paths, a change of the angle between the glide path and the line below the glide path (150 Hz predominating) at which a DDM of 0.0875 is realized by more than plus or minus 0.0375 θ ;
 - iv) for Facility Performance Categories II and III — ILS glide paths, a change of displacement sensitivity to a value differing by more than 25 per cent from the nominal value;
 - v) lowering of the line beneath the ILS glide path at which a DDM of 0.0875 is realized to less than 0.7475 θ from horizontal;
 - vi) a reduction of DDM to less than 0.175 within the specified coverage below the glide path sector.
- (2) Monitoring of the ILS glide path characteristics to smaller tolerances shall be arranged in those cases where operational penalties would otherwise exist.
- (3) The total period of radiation, including period(s) of zero radiation, outside the performance limits specified in 23.1.3.1 (e) (7) (i) shall be as short as practicable, consistent with the need for avoiding interruptions of the navigation service provided by the ILS glide path.
 - i) The total period referred to under 23.1.3.1 (e) (7) (iii) shall not exceed under any circumstances:
 - 6 seconds for Category I — ILS glide paths;
 - 2 seconds for Categories II and III — ILS glide paths.

- ii) Where practicable, the total period specified under above for Categories II and III — ILS glide paths shall not exceed 1 second.
- (4) Design and operation of the monitor system shall be consistent with the requirement that radiation shall cease and a warning shall be provided at the designated remote control points in the event of failure of the monitor system itself.

(l) INTEGRITY AND CONTINUITY OF SERVICE REQUIREMENTS

- (1) The probability of not radiating false guidance signals shall not be less than $1 - 0.5 \times 10^{-9}$ in any one landing for Facility Performance Categories II and III glide paths.
- (2) The probability of not radiating false guidance signals shall not be less than $1 - 1.0 \times 10^{-7}$ in any one landing for facility performance Category I glide paths.
- (3) The probability of not losing the radiated guidance signal shall be greater than $1 - 2 \times 10^{-6}$ in any period of 15 seconds for facility performance Categories II and III glide paths (equivalent to 2000 hours mean time between outages).
- (4) The probability of not losing the radiated guidance signal shall exceed $1 - 4 \times 10^{-6}$ in any period of 15 seconds for facility performance Category 1 glide paths (equivalent to 1000 hours mean time between outages.)

(m) LOCALIZER AND GLIDE PATH FREQUENCY PAIRING

- (1) The pairing of the runway localizer and glide path transmitter frequencies of an instrument landing system shall be taken from the following list in accordance with the provisions of Subpart 23.5.4.2 of Subpart 5 of Part 23:

<i>Localizer (MHz)</i>	<i>Glide path (MHz)</i>	<i>Localizer (MHz)</i>	<i>Glide path (MHz)</i>
108.1	334.7	110.1	334.4
108.15	334.55	110.15	334.25
108.3	334.1	110.3	335.0
108.35	333.95	110.35	334.85
108.5	329.9	110.5	329.6
108.55	329.75	110.55	329.45
108.7	330.5	110.7	330.2
108.75	330.35	110.75	330.05
108.9	329.3	110.9	330.8
108.95	329.15	110.95	330.65
109.1	331.4	111.1	331.7
109.15	331.25	111.15	331.55
109.3	332.0	111.3	332.3
109.35	331.85	111.35	332.15
109.5	332.6	111.5	332.9
109.55	332.45	111.55	332.75
109.7	333.2	111.7	333.5
109.75	333.05	111.75	333.35
109.9	333.8	111.9	331.1
109.95	333.65	111.95	330.95

- i) In those region where the requirements for runway localizer and glide path transmitter frequencies of an instrument landing system do no justify more than 20 pairs, they shall be selected sequentially, as required from the following list:

<i>Sequence number</i>	<i>Localizer (MHz)</i>	<i>Glide path (MHz)</i>
1	110.3	335.0
2	109.9	333.8
3	109.5	332.6
4	110.1	334.4
5	109.7	333.2
6	109.3	332.0
7	109.1	331.4
8	110.9	330.8
9	110.7	330.2
10	110.5	329.6
11	108.1	334.7
12	108.3	334.1
13	108.5	329.9
14	108.7	330.5
15	108.9	329.3
16	111.1	331.7
17	111.3	332.3
18	111.5	332.9
19	111.7	333.5
20	111.9	331.1

- (2) Where existing ILS localizers meeting national requirements are operating on frequencies ending in even tenths of a megahertz, they shall be re- assigned frequencies, conforming with 23.1.3.1 (f) (1) or 23.1.3.1(f) (1) (A) as soon as practicable and may continue operating on their present assignments only until this re-assignment can be effected.
- (3) Existing ILS localizers in the international service operating on frequencies ending in odd tenths of a megahertz shall not be assigned new frequencies ending in odd tenths plus one twentieth of a megahertz except where, by regional agreement, general use may be made of any of the channels listed in 23.1.3.1(f) (1) (A).

(n) VHF MARKER BEACONS

- (1) General
- i) There shall be two marker beacons in each installation except as provided in 23.1.3.1 (g) (6) (vi). A third marker beacon may be added whenever, in the opinion of the Competent Authority, an additional beacon is required because of operational procedures at a particular site.

- ii) The marker beacons shall conform to the requirements prescribed in 23.1.3.1 (g) when the installation comprises only two marker beacons, the requirements applicable to the middle marker and to the outer marker shall be complied with.
- iii) The marker beacons shall produce radiation patterns to indicate predetermined distance from the threshold along the ILS glide path.
 - A. When a marker beacon is used in conjunction with the back course of a localizer, it shall conform with the marker beacon characteristics specified in 23.1.3.1 (g).
 - B. Identification signals of marker beacons used in conjunction with the back course of a localizer shall be clearly distinguishable from the inner, middle and outer marker beacon identifications, as prescribed in 23.1.3.1.7.5.1.
- (2) RADIO FREQUENCY
 - i) The marker beacons shall operate at 75 MHz with a frequency tolerance of plus or minus 0.005 per cent and shall utilize horizontal polarization.
- (3) COVERAGE
 - i) The marker beacon system shall be adjusted to provide coverage over the following distances, measured on the ILS glide path and localizer course line:
 - A. inner marker (where installed): 150 m plus or minus 50m(500ftplus or minus 230 ft);
 - B. middle marker: 300 m plus or minus 100 m (1 000 ft plus or minus 325 ft);
 - C. outer marker: 600 m plus or minus 200 m (2 000 ft plus or minus 650 ft).
 - ii) The field strength at the limits of coverage specified in 23.1.3.1.7.3.1 shall be 1.5 millivolts per metre (minus 82 dBW/m²). In addition, the field strength within the coverage area shall rise to at least 3.0 millivolts per metre (76 dBW/m²).
- (4) MODULATION
 - i) The modulation frequencies shall be as follows:
 - A. inner marker (when installed): 3000 Hz;
 - B. middle marker: 1300 Hz;
 - C. outer marker: 400 Hz. The frequency tolerance of the above frequencies shall be plus or minus 2.5 per cent, and the total harmonic content of each of the frequencies shall not exceed 15 per cent.
 - ii) The depth of modulation of the markers shall be 95 per cent plus or minus 4 per cent.
- (5) IDENTIFICATION
 - i) The carrier energy shall not be interrupted. The audio frequency modulation shall be keyed as follows:
 - A. inner marker (when installed): 6 dots per second continuously;
 - B. middle marker: a continuous series of alternate dots and dashes, the dashes keyed at the rate of 2 dashes per second, and the dots at the rate of 6 dots per second;
 - C. Outer marker: 2 dashes per second continuously. These keying rates shall be maintained to within plus or minus 15 percent.
- (6) SITING

- i) The inner marker, when installed, shall be located so as to indicate in low visibility conditions the imminence of arrival at the runway threshold.
 - A. If the radiation pattern is vertical, the inner marker, when installed, shall be located between 75 in (250ft) and 450 in (1 500fl) from the threshold and at not more than 30 m (100 ft) from the extended centre line of the runway.
 - B. If the radiation pattern is other than vertical, the equipment shall be located so as to produce a field within the course sector and ILS glide path sector that is substantially similar to that produced by an antenna radiating a vertical pattern and located as prescribed in A. above.
 - ii) The middle marker shall be located so as to indicate the imminence, in low visibility conditions, of visual approach guidance.
 - A. If the radiation pattern is vertical, the middle marker shall be located 1050m (3500 ft) plus or minus 150 m (500 ft), from the landing threshold at the approach end of the runway and at not more than 75m (250 ft) from the extended centre line of the runway.
 - B. If the radiation pattern is other than vertical, the equipment shall be located so as to produce a field within the course sector and ILS glide path sector that is substantially similar to that produced by an antenna radiating a vertical pattern and located as prescribed in 23.1.3.1.7.6.2.1.
 - iii) The outer marker shall be located so as to provide height, distance and equipment functioning checks to aircraft on intermediate and final approach.
 - A. The outer marker shall be located 7.2 km (3.9 NM) from the threshold except that, where for topographical or operational reasons this distance is not practicable, the outer marker may be located between 6.5 and 11.1 km (3.5 and 6NM) from the threshold.
 - iv) If the radiation pattern is vertical, the outer marker shall be not more than 75 in (250ft) from the extended centre line of the runway. If the radiation pattern is other than vertical, the equipment shall be located so as to produce a field within the course sector and ILS glide path sector that is substantially similar to that produced by an antenna radiating a vertical pattern.
 - v) The positions of marker beacons, or where applicable, the equivalent distance(s) indicated by the DME when used as an alternative to part or all of the marker beacon component of the ILS, shall be published in accordance with the provisions of Part 15.
 - A. When so used, the DME shall provide distance information operationally equivalent to that furnished by marker beacon(s).
 - B. When used as an alternative for the middle marker, the DME shall be frequency paired with the ILS localizer and sited so as to minimize the error in distance information.
 - C. The DME in 23.1.3.1 (g) (6) (iv) above shall conform to the specification in 23.1.3.5.
- (7) MONITORING
- i) Suitable equipment shall provide signals for the operation of an automatic monitor. The monitor shall transmit a warning to a control point if either of the following conditions arise:
 - A. failure of the modulation or keying;
 - B. reduction of power output to less than 50 per cent of normal.

- ii) For each marker beacon, suitable monitoring equipment shall be provided which will indicate at the appropriate location a decrease of the modulation depth below 50 per cent.

23.1.3.2 SPECIFICATION FOR PRECISION APPROACH RADAR SYSTEM

Note. — *Slant distances are used throughout this specification.*

- (a) The precision approach radar system shall comprise the following elements:

- (1) The precision approach radar element (PAR).
- (2) The surveillance radar element (SRE).

- (b) When the PAR only is used, the installation shall be identified by the term PAR or precision approach radar and not by the term "precision approach radar system".

Note. — *Provisions for the recording and retention of radar data are contained in Subpart 6 of Part 23 of LIBERIA Civil Aviation (ANS) REGULATIONS.*

- (c) THE PRECISION APPROACH RADAR ELEMENT (PAR)

- (1) **COVERAGE**

- i) The PAR shall be capable of detecting and indicating the position of an aircraft of 15 m echoing area or larger, which is within a space bounded by a 20-degree azimuth sector and a 7-degree elevation sector, to a distance of at least 23.7 km (9 NM) from its respective antenna.

Note. — *For guidance in determining the significance of the echoing areas of aircraft, the following table is included:*

private flyer (single-engined): 5 to 10 m²; small twin-engined aircraft: from 15 m²; medium twin-engined aircraft: from 25 m²; four-engined aircraft: from 50 to 100 m².

- (2) **SITING**

- i) The PAR shall be sited and adjusted so that it gives complete coverage of a sector with its apex at a point 150 m (500 ft) from the touchdown in the direction of the stop end of the runway and extending plus or minus 5 degrees about the runway centre line in azimuth and from minus 1 degree to plus 6 degrees in elevation.

Note.— *23.1.3.2 (c) (2) (i) can be met by siting the equipment with a set-back from the touchdown, in the direction of the stop end of the runway, of 915 m (3 000 ft) or more, for an offset of 120 m (400 ft) from the runway centre line, or of 1 200 m (4 000 ft) or more, for an offset of 185 m (600 ft) when the equipment is aligned to scan plus or minus 10 degrees about the centre line of the runway. Alternatively, if the equipment is aligned to scan 15 degrees to one side and 5 degrees to the other side of the centre line of the runway, then the minimum set-back can be reduced to 685 m (2 250 ft) and 915 m (3000 ft) for offsets of 120 m (400 ft) and 185 m (600 ft) respectively.*

- (3) **ACCURACY**

- i) Azimuth accuracy. Azimuth information shall be displayed in such a manner that left-right deviation from the on-course line shall be easily observable. The maximum permissible error with respect to the deviation from the on-course line shall be either 0.6 per cent of the distance from the PAR antenna plus 10 per cent of the deviation from the on-course line or 9 m (30 ft), whichever is greater. The equipment shall be so sited that the error at the touchdown shall not exceed 9 m (30 ft). The equipment shall be so aligned and adjusted that the displayed error at the touchdown shall be a minimum and shall not exceed 0.3 per cent of the distance from the PAR antenna

- or 4.5 m (15 ft), whichever is greater. It shall be possible to resolve the positions of two aircraft which are at 1.2 degrees in azimuth of one another.
- ii) Elevation accuracy. Elevation information shall be displayed in such a manner that up-down deviation from the descent path for which the equipment is set shall be easily observable. The maximum permissible error with respect to the deviation from the on-course line shall be 0.4 per cent of the distance from the PAR antenna plus 10 per cent of the actual linear displacement from the chosen descent path or 6 (20 ft), whichever is greater. The equipment shall be so sited that the error at the touchdown shall not exceed 6 m (20 ft). The equipment shall be so aligned and adjusted that the displayed error at the touchdown shall be a minimum and shall not exceed 0.2 per cent of the distance from the PAR antenna or 3 m (10 ft), whichever is greater. It shall be possible to resolve the positions of two aircraft that are at 0.6 degree in elevation of one another.
 - iii) Distance accuracy. The error in indication of the distance from the touchdown shall not exceed 30 m (100 ft) plus 3 per cent of the distance from the touchdown. It shall be possible to resolve the positions of two aircraft which are at 120 m (400 ft) of one another on the same azimuth.
 - iv) Information shall be made available to permit the position of the controlled aircraft to be established with respect to other aircraft and obstructions. Indications shall also permit appreciation of ground speed and rate of departure from or approach to the desired flight path.
 - v) Information shall be completely renewed at least once every second.
- (4) **THE SURVEILLANCE RADAR ELEMENT (SRE)**
- i) A surveillance radar used as the SRE of a precision approach radar system shall satisfy at least the following broad performance requirements.
 - ii) Coverage
 - A. The SRE shall be capable of detecting aircraft of 15 m² echoing area and larger, which are in line of sight of the antenna within a subpart described as follows:

The rotation through 360 degrees about the antenna of a vertical plane surface bounded by a line at an angle of 1.5 degrees above the horizontal plane of the antenna, extending from the antenna to 37 km (20 NM); by a vertical line at 37 km (20 NM) from the intersection with the 1.5-degree line up to 2 400 m (8 000 ft) above the level of the antenna; by a horizontal line at 2 400 m (8 000 ft) from 37 km (20 NM) back towards the antenna to the intersection with a line from the antenna at 20 degrees above the horizontal plane of the antenna, and by a 20-degree line from the intersection with the 2 400 m (8 000 ft) line to the antenna.
 - B. Efforts shall be made in development to increase the coverage on an aircraft of 15 m² echoing area to at least the subpart obtained by amending 23.1.3.2.4.2.1 above with the following substitutions:
 - for 1.5 degrees, read 0.5 degree',
 - for 37 km (20 NM), read 46.3 km (25 NM);
 - for 2 400 m (8 000ft), read 3 000 m (10 000ft);
 - for 20 degrees, read 30 degrees.
 - iii) Accuracy

- A. Azimuth accuracy. The indication of position in azimuth shall be within plus or minus 2 degrees of the true position. It shall be possible to resolve the positions of two aircraft which are at 4 degrees of azimuth of one another.
 - B. Distance accuracy. The error in distance indication shall not exceed 5 per cent of true distance or 150 m, whichever is the greater. It shall be possible to resolve the positions of two aircraft that are separated by a distance of 1 per cent of the true distance from the point of observation or 230 m (700ft), whichever is the greater.
 - C. The error in distance indication shall not exceed 3 per cent of the true distance or 150 m (500ft), whichever is the greater.
- iv) The equipment shall be capable of completely renewing the information concerning the distance and azimuth of any aircraft within the coverage of the equipment at least once every 4 seconds.
 - v) Efforts shall be made to reduce, as far as possible, the disturbance caused by ground echoes or echoes from clouds and precipitation.

23.1.3.3 SPECIFICATION FOR VHF OMNIDIRECTIONAL RADIO RANGE (VOR)

(a) General

- (1) The VOR shall be constructed and adjusted so that similar instrumental indications in aircraft represent equal clockwise angular deviations (bearings), degree for degree from magnetic North as measured from the location of the VOR.
- (2) The VOR shall radiate a radio frequency carrier with which are associated two separate 30 Hz modulations. One of these modulations shall be such that its phase is independent of the azimuth of the point of observation (reference phase). The other modulation (variable phase) shall be such that its phase at the point of observation differs from that of the reference phase by an angle equal to the bearing of the point of observation with respect to the VOR.
- (3) The reference and variable phase modulations shall be in phase along the reference meridian through the station.

Note. — The reference and variable phase modulations are in phase when the maximum value of the sum of the radio frequency carrier and the sideband energy due to the variable phase modulation occurs at the same time as the highest instantaneous frequency of the reference phase modulation.

(b) Radio frequency

- (1) The VOR shall operate in the band 111.975 MHz to 117.975 MHz except that frequencies in the band 108 MHz to 111.975 MHz may be used when, in accordance with the provisions of 23.5.4.4.2.1 and 23.5.4.4.2.3.1, the use of such frequencies is acceptable. The highest assignable frequency shall be 117.950 MHz. The channel separation shall be in increments of 50 kHz referred to the highest assignable frequency. In areas where 100 kHz or 200 kHz channel spacing is in general use, the frequency tolerance of the radiofrequency carrier shall be plus or minus 0.005 per cent.
- (2) The frequency tolerance of the radio frequency carrier of all new installations implemented after 23 May 1974 in areas where 50 kHz channel spacing is in use shall be plus or minus 0.002 per cent.
- (3) In areas where new VOR installations are implemented and are assigned frequencies spaced at 50 kHz from existing VORs in the same area, priority

shall be given to ensuring that the frequency tolerance of the radio frequency carrier of the existing VORs is reduced to plus or minus 0.002 per cent.

(c) Polarization and pattern accuracy

- (1) The emission from the VOR shall be horizontally polarized. The vertically polarized component of the radiation shall be as small as possible.
- (2) The accuracy of the bearing information conveyed by the horizontally polarized radiation from the VOR at a distance of approximately four wavelengths for all elevation angles between 0 and 40 degrees, measured from the centre of the VOR antenna system, shall be within plus minus 2 degrees.

(d) Coverage

- (1) The VOR shall provide signals such as to permit satisfactory operation of a typical aircraft installation at the levels and distances required for operational reasons, and up to an elevation angle of 40 degrees.
- (2) The field strength or power density in space of VOR signals required to permit satisfactory operation of a typical aircraft installation at the minimum service level at the maximum specified service radius shall be 90 microvolts per metre or minus 107 dBW/m².

(e) Modulations of navigational signals

- (1) The radio frequency carrier as observed at any point in space shall be amplitude modulated by two signals as follows:
 - i) subcarrier of 9 960 Hz of constant amplitude, frequency modulated at 30 Hz and having a deviation ratio of 23 plus or minus 1 (i.e. 15 to 17):
 - A. for the conventional VOR, the 30 Hz component of this FM subcarrier is fixed without respect to azimuth and is termed the "reference phase";
 - B. for the Doppler VOR, the phase of the 30 Hz component varies with azimuth and is termed the "variable phase";
 - ii) a 30 Hz amplitude modulation component:
 - A. for the conventional VOR, this component results from a rotating field pattern, the phase of which varies with azimuth, and is termed the "variable phase";
 - B. for the Doppler VOR, this component, of constant phase with relation to azimuth and constant amplitude, is radiated omnidirectionally and is termed the "reference phase".

- (2) The depth of modulation of the radio frequency carrier due to the subcarrier of 9 960 Hz shall be within the limits of 28 per cent and 32 per cent.
- (3) The depth of modulation of the radio frequency carrier due to the 30Hz signal, as observed at any angle of elevation up to 5 degrees, shall be within the limits of 25 to 35 per cent. The depth of modulation of the radio frequency carrier due to the 9 960 Hz signal, as observed at any angle of elevation up to 5 degrees, shall be within the limits of 20 to 55 per cent on facilities without voice modulation, and within the limits of 20 to 35 per cent on facilities with voice modulation.

Note. — When modulation is measured during flight testing under strong dynamic multipath conditions, variations in the received modulation percentages are to be expected. Short-term variations beyond these values may be acceptable. The Manual on Testing of Radio Navigation Aids (Doc 8071) contains additional information on the application of airborne modulation tolerances.

- (4) The variable and reference phase modulation frequencies shall be 30 Hz within plus or minus 1 per cent.

- (5) The subcarrier modulation mid-frequency shall be 9 960 Hz within plus or minus 1 per cent.
- (6) For the conventional VOR, the percentage of amplitude modulation of the 9 960 Hz subcarrier shall not exceed 5 per cent.
- i) For the Doppler VOR, the percentage of amplitude modulation of the 9 960 Hz subcarrier shall not exceed 40 per cent when measured at a point at least 300 m (1000ft) from the VOR.
- (7) Where 50 kHz VOR channel spacing is implemented, the sideband level of the harmonics of the 9 960 Hz component in the radiated signal shall not exceed the following levels referred to the level of the 9 960 Hz sideband:

Subcarrier	Level
9 960 Hz	0 dB reference
2nd harmonic	-30 dB
3rd harmonic	-50 dB
4th harmonic and above	-60 dB

(f) Voice and identification

- (1) If the VOR provides a simultaneous communication channel ground-to-air, it shall be on the same radio frequency carrier as used for the navigational function. The radiation on this channel shall be horizontally polarized.
- (2) The peak modulation depth of the carrier on the communication channel shall not be greater than 30 per cent.
- (3) The audio frequency characteristics of the speech channel shall be within 3 dB relative to the level at 1 000 Hz over the range 300 Hz to 3000 Hz.
- (4) The VOR shall provide for the simultaneous transmission of a signal of identification on the same radio frequency carrier as that used for the navigational function. The identification signal radiation shall be horizontally polarized.
- (5) The identification signal shall employ the International Morse Code and consist of two or three letters. It shall be sent at a speed corresponding to approximately 7 words per minute. The signal shall be repeated at least once every 30 seconds and the modulation tone shall be 1 020 Hz within plus or minus 50 Hz.
 - i) The identification signal shall be transmitted at least three times each 30 seconds, spaced equally within that time period. One of these identification signals may take the form of a voice identification.
- (6) The depth to which the radio frequency carrier is modulated by the code identification signal shall be close to, but not in excess of 10 per cent except that, where a communication channel is not provided, it shall be permissible to increase the modulation by the code identification signal to a value not exceeding 20 per cent.
 - i) If the VOR provides a simultaneous communication channel ground-to-air, the modulation depth of the code identification signal shall be 5 plus or minus 1 per cent in order to provide a satisfactory voice quality.
- (7) The transmission of speech shall not interfere in any way with the basic navigational function. When speech is being radiated, the code identification shall not be suppressed.

- (8) The VOR receiving function shall permit positive identification of the wanted signal under the signal conditions encountered within the specified coverage limits, and with the modulation parameters specified at 23.1.3.3 (f) (5), 23.1.3.3 (f) (6) and 23.1.3.3 (f) (7) above.

(g) Monitoring

- (1) Suitable equipment located in the radiation field shall provide signals for the operation of an automatic monitor. The monitor shall transmit a warning to a control point, and either remove the identification and navigation components from the carrier or cause radiation to cease if anyone or a combination of the following deviations from established conditions arises:
- i) a change in excess of 1 degree at the monitor site of the bearing information transmitted by the VOR;
 - ii) a reduction of 15 per cent in the modulation components of the radio frequency signals voltage level at the monitor of either the subcarrier, or 30 Hz amplitude modulation signals, or both.
- (2) Failure of the monitor itself shall transmit a warning to a control point and either:
- i) remove the identification and navigation components from the carrier; or
 - ii) cause radiation to cease.

(h) Interference immunity performance for VOR receiving systems

- (1) The VOR receiving system shall provide adequate immunity to interference from two signal, third-order intermodulation products caused by VHF FM broadcast signals having levels in accordance with the following:

$$2N1 + N2 + 72 \leq 0$$

for VHF FM sound broadcasting signals in the range 107.7-
108.0 MHz

and

$$2N1 + N2 + 3(24 - 20 \log \Delta f / 0.4) \leq 0$$

for VHF FM sound broadcasting signals below 107.7 MHz,

where the frequencies of the two VHF FM sound broadcasting signals produce, within the receiver, a two signal, third-order intermodulation product on the desired VOR frequency.

N1 and N2 are the levels (dBm) of the two VHF FM sound

broadcasting signals at the VOR receiver input. Neither level shall exceed the desensitization criteria set forth in 23.1.3.3.8.2 below.

$\Delta f = 108.1 - f_1$, where f_1 is the frequency of N1, the VHF FM sound broadcasting signal closer to 108.1 MHz.

- (2) The VOR receiving system shall not be desensitized in the presence of VHF FM broadcast signals having levels in accordance with the following table:

<i>Frequency (MHz)</i>	<i>Maximum level of unwanted signal at receiver input (dBm)</i>
88-102	+15
104	+10
106	+ 5
107.9	-10

23.1.3.4 SPECIFICATION FOR NON-DIRECTIONAL RADIO BEACON (NDB)

(a) Definitions

- (1) **Average radius of rated coverage.** The radius of a circle having the same area as the rated coverage.
- (2) **Effective coverage.** The area surrounding an NDB within which bearings can be obtained with an accuracy sufficient for the nature of the operation concerned.
- (3) **Locator.** An LF/MF NDB used as an aid to final approach.
- (4) **Rated coverage.** The area surrounding an NDB within which the strength of the vertical field of the ground wave exceeds the minimum value specified for the geographical area in which the radio beacon is situated.

(b) Coverage

- (1) The minimum value of field strength in the rated coverage of an NDB shall be 70 microvolts per metre.
- (2) All notifications or promulgations of NDBs shall be based upon the average radius of the rated coverage.
- (3) Where the rated coverage of an NDB is materially different in various operationally significant sectors, its classification shall be expressed in terms of the average radius of rated coverage and the angular limits of each sector as follows:
Radius of coverage of sector or angular limits of sector expressed as magnetic bearing clockwise from the beacon.
Where it is desirable to classify an NDB in such a manner, the number of sectors shall be kept to a minimum and preferably shall not exceed two.

(c) Limitations in radiated power

The power radiated from an NDB shall not exceed by more than 2dB that necessary to achieve its agreed rated coverage, except that this power may be increased if coordinated regionally or if no harmful interference to other facilities will result.

(d) Radio frequencies

- (1) The radio frequencies assigned to NDBs shall be selected from those available in that portion of the spectrum between 190 kHz and 1750 kHz.
- (2) The frequency tolerance applicable to NDBs shall be 0.01 per cent except that, for NDBs of antenna power above 200 W using frequencies of 2306.5 kHz and above, the tolerance shall be 0.005 per cent.
- (3) Where two locators are used as supplements to an ILS, the frequency separation between the carriers of the two shall be not less than 15 kHz. to ensure correct operation of the radio compass, and preferably not more than 25 kHz in order to permit a quick tuning shift in cases where an aircraft has only one radio compass.
- (4) Where locators associated with ILS facilities serving opposite ends of a single runway are assigned a common frequency, provision shall be made to ensure that the facility not in operational use cannot radiate.

Note. — Additional guidance on the operation of locator beacons on common frequency channels is contained in 23.5.3.3.2.2.

(e) Identification

- (1) Each NDB shall be individually identified by a two- or three-letter International Morse Code group transmitted at a rate corresponding to approximately 7 words per minute.
- (2) The complete identification shall be transmitted at least once every 30 seconds, except where the beacon identification is effected by on/off keying of the carrier. In this latter case, the identification shall be at approximately 1- minute intervals, except that a shorter interval may be used at particular NDB stations where this is found to be operationally desirable.
 - i) Except for those cases where the beacon identification is effected by on/off keying of the carrier, the identification signal shall be transmitted at least three times each 30 seconds, spaced equally within that time period.
- (3) For NDBs with an average radius of rated coverage of 92.7 km (50 NM) or less that are primarily approach and holding aids in the vicinity of an aerodrome, the identification shall be transmitted at least three times each 30 seconds, spaced equally within that time period.
- (4) The frequency of the modulating tone used for identification shall be 1020 Hz plus or minus 50 Hz or 400 Hz plus or minus 25 Hz.

(f) Characteristics of emissions

- (1) Except as provided in ((f) (2)), all NDBs shall radiate an uninterrupted carrier and be identified by on/off keying of an amplitude modulating tone (NON/A2A).
- (2) NDBs other than those wholly or partly serving as holding, approach and landing aids, or those having an average radius of rated coverage of less than 92.7 km (50 NM), may be identified by on/off keying of the unmodulated carrier (NON/A1 A) if they are in areas of high beacon density and/or where the required rated coverage is not practicable of achievement because of:
 - i) radio interference from radio stations;
 - ii) high atmospheric noise;
 - iii) local conditions.
- (3) For each NDB identified by on/off keying of an audio modulating tone, the depth of modulation shall be maintained as near to 95 percent as practicable.

- (4) For each NDB identified by on/off keying of an audio modulating tone, the characteristics of emission during identification shall be such as to ensure satisfactory identification at the limit of its rated coverage.
- (5) The carrier power of an NDB with NON/A2A emissions shall not fall when the identity signal is being radiated except that, in the case of an NDB having an average radius of rated coverage exceeding 92.7 km (50 NM), a fall of not more than 1.5 dB may be accepted,
- (6) Unwanted audio frequency modulations shall total less than 5 percent of the amplitude of the carrier.
- (7) The bandwidth of emissions and the level of spurious emissions shall be kept at the lowest value that the state of technique and the nature of the service permit.

(g) Siting of locators

- (1) Where locators are used as a supplement to the ILS, they shall be located at the sites of the outer and middle marker beacons. Where only one locator is used as a supplement to the ILS, preference shall be given to location at the site of the outer marker beacon. Where locators are employed as an aid to final approach in the absence of an ILS, equivalent locations to those applying when an ILS is installed shall be selected, taking into account the relevant obstacle clearance provisions of the Procedures for Air Navigation Services —Aircraft Operations (Part 8).
- (2) Where locators are installed at both the middle and outer marker positions, they shall be located, where practicable, on the same side of the extended centre line of the runway in order to provide a track between the locators which will be more nearly parallel to the centre line of the runway.

(h) Monitoring

- (1) For each NDB, suitable means shall be provided to enable detection of any of the following conditions at an appropriate location:
 - i) decrease in radiated carrier power of more than 50 percent below that required for the rated coverage;
 - ii) failure to transmit the identification signal;
 - iii) malfunctioning or failure of the means of monitoring itself.
- (2) When an NDB is operated from a power source having a frequency which is close to airborne ADF equipment switching frequencies, and where the design of the NDB is such that the power supply frequency is likely to appear as a modulation product on the emission, the means of monitoring shall be capable of detecting such power supply modulation on the carrier in excess of 5 percent.
- (3) During the hours of service of a locator, the means of monitoring shall provide for a continuous check on the functioning of the locator as prescribed in 23.1.3.4 (h) (1) above.
- (4) During the hours of service of an NDB other than a locator, the means of monitoring shall provide for a continuous check on the functioning of the NDB as prescribed in 23.1.3.4 (h) (1).

23.1.3.5 SPECIFICATION FOR UHF DISTANCE MEASURING EQUIPMENT (DME)

(a) Definitions

- (1) **Control motion noise (CMN).** That portion of the guidance signal error which causes control surface, wheel and column motion and could affect aircraft attitude angle during coupled flight, but does not cause aircraft displacement from the desired course and or glide path.

- (2) **DME dead time.** A period immediately following the decoding of a valid interrogation during which a received interrogation will not cause a reply to be generated.
- (3) **DME/N.** Distance measuring equipment, primarily serving operational needs of en-route or TMA navigation, where the "N" stands for narrow spectrum characteristics (to be distinguished from "W").
- (4) **DME/P.** The distance measuring element of the MLS, where the "P" stands for precise distance measurement. The spectrum characteristics are those of DME/N.
- (5) **DME/W.** Distance measuring equipment, primarily serving operational needs of en-route or TMA navigation, where the "W" stands for wide spectrum characteristics (to be distinguished from "N").
- (6) **Equivalent isotropically radiated power (e.i.r.p.).** The product of the power supplied to the antenna and the antenna gain in a given direction relative to an isotropic antenna (absolute or isotropic gain).
- (7) **Final approach (FA) mode.** The condition of DME/P operation which supports flight operations in the final approach and runway regions.
- (8) **Initial approach (IA) mode.** The condition of DMEyp operation which supports those flight operations outside the final approach region and which is interoperable with DME/N.
- (9) **Key down time.** The time during which a dot or dash of a Morse character is being transmitted.
- (10) **MLS approach reference datum.** A point on the minimum glide path at a specified height above the threshold. (See 23.1.3.10 below.)
- (11) **MLS datum point.** The point on the runway centre line closest to the phase centre of the approach elevation antenna. (See 23.1.3.10 below.)
- (12) **Mode W, X, Y, Z.** A method of coding the DME transmissions by time spacing pulses of a pulse pair, so that each frequency can be used more than once.
- (13) **Partial rise time.** The time as measured between the 5 and 30 per cent amplitude points on the leading edge of the pulse envelope, i.e. between points h and i on Figures 3-1 and 3-2.
- (14) **Path following error (PFE).** That portion of the guidance signal error which could cause aircraft displacement from the desired course and/or glide path. (See 23.1.3.10 below.)
- (15) **Pulse amplitude.** The maximum voltage of the pulse envelope, i.e. A in Figure 3-1.
- (16) **Pulse decay time.** The time as measured between the 90 and 10 per cent amplitude points on the trailing edge of the pulse envelope, i.e. between points e and g on Figure 3-1.
- (17) **Pulse code.** The method of differentiating between W, X, Y and Z modes and between FA and IA modes.
- (18) **Pulse duration.** The time interval between the 50 per cent amplitude point on leading and trailing edges of the pulse envelope, i.e. between points b and f on Figure 3-1.
- (19) **Pulse rise time.** The time as measured between the 10 and 90 per cent amplitude points on the leading edge of the pulse envelope, i.e. between points a and c on Figure 3-1.
- (20) **Reply efficiency.** The ratio of replies transmitted by the transponder to the total of received valid interrogations.
- (21) **Search.** The condition which exists when the DME interrogator is attempting to acquire and lock onto the response to its own interrogations from the selected transponder,
- (22) **System efficiency.** The ratio of valid replies processed by the interrogator to the total of its own interrogations.

- (23) **Track.** The condition which exists when the DME interrogator has locked onto replies in response to its own interrogations, and is continuously providing a distance measurement.
- (24) **Transmission rate.** The average number of pulse pairs transmitted from the transponder per second.
- (25) **Virtual origin.** The point at which the straight line through the 30 per cent and 5 per cent amplitude points on the pulse leading edge intersects the 0 per cent amplitude axis (see Figure 3-2).

(b) General

- (1) The DME system shall provide for continuous and accurate indication in the cockpit of the slant range distance of an equipped aircraft from an equipped ground reference point.
- (2) The system shall comprise two basic components, one fitted in the aircraft, the other installed on the ground. The aircraft component shall be referred to as the interrogator and the ground component as the transponder.
- (3) In operation interrogators shall interrogate transponders which shall, in turn, transmit to the interrogator replies synchronized with the interrogations, thus providing means for accurate measurement of distance.
- (4) DME/P shall have two operating modes, IA and FA.

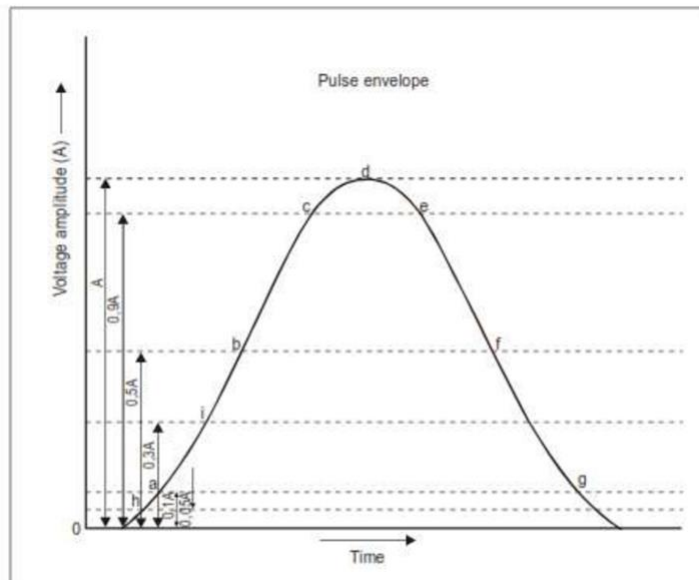

Figure 3-1

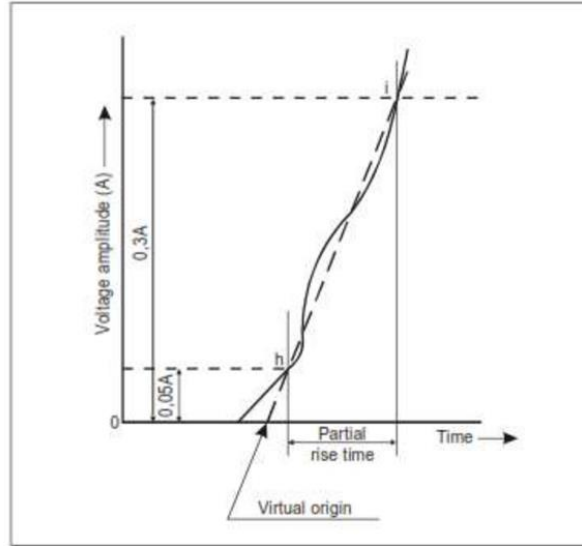

Figure 3-2

- (5) When a DME is associated with an ILS, MLS or VOR for the purpose of constituting a single facility, they shall:
 - i) be operated on a standard frequency pairing in accordance with 23.1.3.5(8) below;
 - ii) be collocated within the limits prescribed for associated facilities in 23.1.3.5(6) below; and
 - iii) comply with the identification provisions of 23.1.3.5(9)(ix) below.
- (6) Collocation limits for a DME facility associated with an ILS, MLS or VOR facility
- (7) Associated VOR and DME facilities shall be collocated in accordance with the following:
 - i) for those facilities used in terminal areas for approach purposes or other procedures where the highest position fixing accuracy of system capability is required, the separation of the VOR and DME antennas does not exceed 80 m (260 ft);
 - ii) for purposes other than those indicated in a), the separation of the VOR and DME antennas does not exceed 600 m (2 000 ft).
- (8) Association of DME with ILS
Guidance on the association of DME with ILS are specified in IS: 23.1.3.5 (b) (6) (ii)
- (9) Association of DME with MLS
 - i) If a DME/P is used to provide ranging information, it shall be sited as close as possible to the MLS azimuth facility.
- (10) The Provisions in 23.1.3.5 (c), 23.1.3.5 (d) and 23.1.3.5 (e) denoted by ‡ shall apply only to DME equipment first installed after 1 January 1989.

(c) System characteristics

- (1) Performance
 - i) Range. The system shall provide a means of measurement of slant range distance from an aircraft to a selected transponder to the limit of coverage prescribed by the operational requirements for the selected transponder.
 - ii) Coverage
 - A. When associated with a VOR, DME/N coverage shall be at least that of the VOR to the extent practicable.
 - B. When associated with either an ILS or an MLS, DME/N coverage shall be at least that of the respective ILS or of the MLS azimuth angle guidance coverage sectors.
 - C. DME/P coverage shall be at least that provided by the MLS azimuth angle guidance coverage sectors.
 - iii) Accuracy
 - A. System accuracy. The accuracy standards specified in 23.1.3.5 (c) (1) (iv), 23.1.3.5 (d) (5) and 23.1.3.5 (e) (4) shall be met on a 95 per cent probability basis.
 - iv) DME/P accuracy
 - A. Error components. The path following error (PFE) shall be comprised of those frequency components of the DME/P error at the output of the interrogator which lie below 1.5 rad/s. The control motion noise (CMN) shall be comprised of those frequency components of the DME/P error at the output of the interrogator which lie between 0.5 rad/s and 10 rad/s.
 - B. Errors on the extended runway centre line shall not exceed the values given in Table B at the end of this Subpart.
 - C. In the approach sector, away from the extended runway centre line, the allowable PFE for both standard 1 and standard 2 shall be permitted to increase linearly with angle up to plus or minus 40 degrees MLS azimuth angle where the permitted error is 1.5 times that on the extended runway centre line at the same distance. The allowable CMN shall not increase with angle. There shall be no degradation of either PEE or CMN with elevation angle.
- (2) Radio frequencies and polarization. The system shall operate with vertical polarization in the frequency band 960 MHz to 1215 MHz. The interrogation and reply frequencies shall be assigned with 1-MHz spacing between channels.
- (3) Channelling
 - i) DME operating channels shall be formed by pairing interrogation and reply frequencies and by pulse coding on the paired frequencies.
 - ii) Pulse coding. DME/P channels shall have two different interrogation pulse codes as shown in the table of 23.1.3.5.4.4.1. One shall be used in the initial approach (IA) mode; the other shall be used in the final approach (FA) mode.
 - iii) DME operating channels shall be chosen from Table A (located at the end of this Subpart), of 352 channels in which the channel numbers, frequencies, and pulse codes are assigned.
 - iv) Channel pairing. When a DME transponder is intended to operate in association with a single VHF navigation facility in the 108 MHz to 117.95 MHz frequency band and/or an MLS angle facility in the 5 031.0 MHz to 5 090.7 MHz frequency band, the DME operating channel shall

be paired with the VHF channel and/or MLS angle frequency as given in Table A.

Note.— There may be instances when a DME channel will be paired with both the ILS frequency and an MLS channel (see Subpart 23.5.4.3 of this Part).

(4) Interrogation pulse repetition frequency

Note.— If the interrogator operates on more than one channel in one second, the following specifications apply to the sum of interrogations on all channels.

- i) DME/N. The interrogator average pulse repetition frequency (PRF) shall not exceed 30 pairs of pulses per second, based on the assumption that at least 95 per cent of the time is occupied for tracking.
- ii) DME/N. If it is desired to decrease the time of search, the PRF may be increased during search but shall not exceed 150 pairs of pulses per second.
- iii) DME/N. After 15 000 pairs of pulses have been transmitted without acquiring indication of distance, the PRF shall not exceed 60 pairs of pulses per second thereafter, until a change in operating channel is made or successful search is completed.
- iv) DME/N. When, after a time period of 30 seconds, tracking has not been established the pulse pair repetition frequency shall not exceed 30 pulse pairs per second thereafter.
- v) DME/P. The interrogator pulse repetition frequency shall not exceed the following number of pulse pairs per second:

A.	search	40
B.	aircraft on the ground	5
C.	initial approach mode track	23
D.	final approach mode track	40

(5) Aircraft handling capacity of the system

- i) The aircraft handling capacity of transponders in an area shall be adequate for the peak traffic of the area or 100 aircraft, whichever is the lesser.
- ii) Where the peak traffic in an area exceeds 100 aircraft, the transponder shall be capable of handling that peak traffic.

(6) Transponder identification

- i) All transponders shall transmit an identification signal in one of the following forms as required by 23.1.3.5.3.6.5 below:
 - A. an "independent" identification consisting of coded (International Morse Code) identity pulses which can be used with all transponders;
 - B. an "associated" signal which can be used for transponders specifically associated with a VHP navigation or an MLS angle guidance facility which itself transmits an identification signal.

Note.— An MLS angle guidance facility provides its identification as a digital word transmitted on the data channel into the approach and back azimuth coverage regions as specified in 23.1.3.10 (d) (6) (ii) (A).

- ii) Both systems of identification shall use signals, which shall consist of the transmission for an appropriate period of a series of paired pulses transmitted at a repetition rate of 1 350 pulse pairs per second, and shall temporarily replace all reply pulses that would normally occur at that time except as in 23.1.3.5 (c) (6) (ii) (B) below. These pulses shall have similar characteristics to the other pulses of the reply signals.
- A. DME/N. Reply pulses shall be transmitted between key down times.
 - B. DME/N. If it is desired to preserve a constant duty cycle, an equalizing pair of pulses, having the same characteristics as the identification pulse pairs, shall be transmitted 100 microseconds plus or minus 10 microseconds after each identity pair.
 - C. DME/P. Reply pulses shall be transmitted between key down times.
 - D. For the DME/P transponder, reply pulse pairs to valid FA mode interrogations shall also be transmitted during key down times and have priority over identification pulse pairs.
 - E. The DME/P transponder shall not employ the equalizing pair of pulses of 23.1.3.5 (c) (6) (ii) (B) above.
- iii) The characteristics of the "independent" identification signal shall be as follows:
- A. the identity signal shall consist of the transmission of the beacon code in the form of dots and dashes (International Morse Code) of identity pulses at least once every 40 seconds, at a rate of at least 6 words per minute; and
 - B. the identification code characteristic and letter rate for the DME, transponder shall conform to the following to ensure that the maximum total key down time does not exceed 5 seconds per identification code group. The dots shall be a time duration of 0.1 second to 0.230 second. The dashes shall be typically 3 times the duration of the dots. The duration between dots and/or dashes shall be equal to that of one dot plus or minus 10 per cent. The time duration between letters or numerals shall not be less than three dots. The total period for transmission of an identification code group shall not exceed 10 seconds.
- Note.— The tone identification signal is transmitted at a repetition rate of 1 350 pps. This frequency may be used directly in the airborne equipment as an aural output for the pilot, or other frequencies may be generated at the option of the interrogator designer (see 23.1.3.5 (c) (6) (ii)).*
- iv) The characteristics of the "associated" signal shall be as follows:
- A. when associated with a VHF or an MLS angle facility, the identification shall be transmitted in the form of dots and dashes (International Morse Code) as in 23.1.3.5.3,6.3 above and shall be synchronized with the VHF facility identification code;
 - B. each 40-second interval shall be divided into four or more equal periods, with the transponder identification transmitted during one period only and the associated VHF and MLS angle

- facility identification, where these are provided, transmitted during the remaining periods;
- C. for a DME transponder associated with an MLS, the identification shall be the last three letters of the MLS angle facility identification specified in 23.1.3.10 (d) (6) (ii) (A) below.
- v) Identification implementation
- A. The "independent" identification code shall be employed wherever a transponder is not specifically associated with a VHF navigational facility or an MLS facility.
- B. Wherever a transponder is specifically associated with a VHF navigational facility or an MLS facility, identification shall be provided by the "associated" code.
- C. When voice communications are being radiated on an associated VHF navigational facility, an "associated" signal from the transponder shall not be suppressed.
- (7) DME/P mode transition
- i) The DME/P interrogator for Standard 1 accuracy shall change from IA mode track to FA mode track at 13 km (7 NM) from the transponder when approaching the transponder, or any other situation when within 13 km (7 NM).
- ii) For Standard 1 accuracy, the transition from IA mode to FA mode track operation may be initiated within 14.8 km (8 NM) from the transponder. Outside 14.8 km (8 NM), the interrogator shall not interrogate in the FA mode.
- Note. — Paragraph 23.1.3.5. (c) (7) (i) does not apply if the transponder is a DME/N or if the DME/P transponder FA mode is inoperative.*
- (8) System efficiency. The DME/P system accuracy of 23.1.3.5(c) (1) (iii) (D) above shall be achieved with a system efficiency of 50 per cent or more.
- (d) Detailed technical characteristics of transponder and associated monitor**
- (1) Transmitter
- i) Frequency of operation. The transponder shall transmit on the reply frequency appropriate to the assigned DME channel (see 23.1.3.5(c) (1) (iii) (C) above).
- ii) Frequency stability. The radio frequency of operation shall not vary more than plus or minus 0.002 per cent from the assigned frequency.
- iii) Pulse shape and spectrum. The following shall apply to all radiated pulses:
- * Pulse rise time.
- A. DME/N. Pulse rise time shall not exceed 3 microseconds.
- B. DME/P. Pulse rise time shall not exceed 1.6 microseconds. For the FA mode, the pulse shall have a partial rise time of 0.25 plus or minus 0.05microsecond. With respect to the FA mode and accuracy standard 1, the slope of the pulse in the partial rise time shall not vary by more than plus or minus 20 per cent. For accuracy standard 2, the slope shall not vary by more than plus or minus 10 per cent.
- C. DME/P. Pulse rise time shall not exceed 1.2 microseconds.

- D. Pulse duration shall be 3.5 microseconds plus or minus 0.5 microsecond.
 - E. Pulse decay time shall nominally be 2.5 microseconds but shall not exceed 3.5 microseconds
 - F. The instantaneous amplitude of the pulse shall not, at any instant between the point of the leading edge which is 95 per cent of maximum amplitude and the point of the trailing edge which is 95 per cent of the maximum amplitude, fall below a value which is 95 per cent of the maximum voltage amplitude of the pulse.
 - G. For DME/N and DME/P: the spectrum of the pulse modulated signal shall be such that during the pulse the effective radiated power contained in a 0.5 MHz band centred on frequencies 0.8 MHz above and 0.8 MHz below the nominal channel frequency in each case shall not exceed 200 mW, and the effective radiated power contained in a 0.5 MHz band centred on frequencies 2 MHz above and 2 MHz below the nominal channel frequency in each case shall not exceed 2 mW. The effective radiated power contained within any 0.5 MHz band shall decrease monotonically as the band centre frequency moves away from the nominal channel frequency.
 - H. For DME/W, the spectrum of the pulse modulated signal shall be such that during the pulse the effective radiated power contained in a 0.5 MHz band centred on frequencies 1.8 MHz above and 1.8 MHz below the nominal channel frequency in each case shall not exceed 200 mW, and the effective radiated power contained in a 0.5 MHz band centred on frequencies 3 MHz above and 3 MHz below the nominal channel frequency in each case shall not exceed 2 mW. Any lobe of the spectrum shall be of less amplitude than the adjacent lobe nearer the nominal channel frequency.
 - I. To ensure proper operation of the thresholding techniques, the instantaneous magnitude of any pulse turn-on transients which occur in time prior to the virtual origin shall be less than one per cent of the pulse peak amplitude. Initiation of the turn-on process shall not commence sooner than 1 microsecond prior to the virtual origin.
- iv) Pulse spacing
- A. The spacing of the constituent pulses of transmitted pulse pairs shall be as given in the table in 23.1.3.5 (d) (4) (i).
 - B. DME/N. The tolerance on the pulse spacing shall be plus or minus 0.25 microseconds.
 - C. DME/N. The tolerance on the DME/N pulse spacing shall be plus or minus 0.10 microsecond.
 - D. DME/P. The tolerance on the pulse spacing shall be plus or minus 0.10 microseconds.
 - E. The pulse spacings shall be measured between the half voltage points on the leading edges of the pulses.
- v) Peak power output

- A. DME/N. The peak effective radiated power shall not be less than that required to ensure a peak pulse power density of approximately minus 83 dBW/m² at the maximum specified service range and level.
 - B. DME/N. The peak equivalent isotropically radiated power shall not be less than that required to ensure a peak pulse power density of minus 89 dB W/ m² under all operational weather conditions at any point within coverage specified in 23.1.3.5 (c) (1) (ii) above.
 - C. DME/P. The peak equivalent isotropically radiated power shall not be less than that required to ensure the following peak pulse power densities under all operational weather conditions:
 - D. minus 89 dBW/m² at any point within the coverage specified in 23.1.3.5 (c) (1) (ii)above at ranges greater than 13 km (7 NM) from the transponder antenna;
 - E. minus 75 dBW/m² at any point within the coverage specified in 23.1.3.5 (c) (1) (ii)above at ranges less than 13 km (7 NM) from the transponder antenna;
 - F. minus 70 dBW/m² at the MLS approach reference datum;
 - G. minus 79 dBW/m² at 2.5 m (8 ft) above the runway surface, at the MLS datum point, or at the farthest point on the runway centre line which is in line of sight of the DME transponder antenna.
 - H. The peak power of the constituent pulses of any pair of pulses shall not differ by more than 1 dB.
 - I. The reply capability of the transmitter shall be such that the transponder shall be capable of continuous operation at a transmission rate of 2700 plus or minus 90 pulse pairs per second (if 100 aircraft are to be served).
 - J. The transmitter shall operate at a transmission rate, including randomly distributed pulse pairs and distance reply pulse pairs, of not less than 700 pulse pairs per second except during identity. The minimum transmission rate shall be as close as practicable to 700 pulse pairs per second. For DME/P, in no case shall it exceed 1200 pulse pairs per second.
- vi) Spurious radiation. During intervals between transmission of individual pulses, the spurious power received and measured in a receiver having the same characteristics as a transponder receiver, but tuned to any DME interrogation or reply frequency, shall be more than 50 dB below the peak pulse power received and measured in the same receiver tuned to the reply frequency in use during the transmission of the required pulses. This provision refers to all spurious transmissions, including modulator and electrical interference.
- A. DME/N. The spurious power level specified in 23.1.3.5 (d) (1) (vi) above shall be more than 80 dB below the peak pulse power level.
 - B. DME/P. The spurious power level specified in 23.1.3.5 (d) (1) (vi) above shall be more than 80 dB below the peak pulse power level.
 - C. Out-of-band spurious radiation. At all frequencies from 10 to 1800MHz, but excluding the band of frequencies from 960 to 1 215 MHz, the spurious output of the DME transponder transmitter shall not exceed minus 40 dBm in any one kHz of receiver bandwidth.

- D. The equivalent isotropically radiated power of any CW harmonic of the carrier frequency on any DME operating channel shall not exceed minus 10 dBm.
- (2) Receiver
- i) Frequency of operation. The receiver centre frequency shall be the interrogation frequency appropriate to the assigned DME operating channel (see 23.1.3.5 (c) (3) (iii) above).
- ii) Frequency stability. The centre frequency of the receiver shall not vary more than plus or minus 0.002 per cent from the assigned frequency.
- iii) Transponder sensitivity
- A. In the absence of all interrogation pulse pairs, with the exception of those necessary to perform the sensitivity measurement, interrogation pulse pairs with the correct spacing and nominal frequency shall trigger the transponder if the peak power density at the transponder antenna is at least:
- B. minus 103 dBW/m² for DME/N with coverage range greater than 56 km (30 NM);
- C. minus 93 dBW/m² for DME/N with coverage range not greater than 56 km (30 NM);
- D. minus 86 dBW/m² for DME/P IA mode;
- E. minus 75 dBW/m² for DME/P FA mode.
- F. The minimum power densities specified in 23.1.3.5 (d) (2) (iii) (A) above shall cause the transponder to reply with an efficiency of at least:
- G. 70 per cent for DME/N;
- H. 70 per cent for DME/P IA mode;
- I. 80 per cent for DME/P FA mode.
- J. ‡DME/N dynamic range. The performance of the transponder shall be maintained when the power density of the interrogation signal at the transponder antenna has any value between the minimum up to a maximum of minus 22 dBW/m² when installed with ILS or MLS and minus 35 dBW/m² when installed for other applications.
- K. DME/P dynamic range. The performance of the transponder shall be maintained when the power density of the interrogation signal at the transponder antenna has any value between the minimum up to a maximum of minus 22 dBW/m².
- L. The transponder sensitivity level shall not vary by more than 1 dB for transponder loadings between 0 and 90 per cent of its maximum transmission rate.
- M. ‡DME/N. When the spacing of an interrogator pulse pair varies from the nominal value by up to plus or minus 1 microsecond, the receiver sensitivity shall not be reduced by more than 1 dB.
- N. DME/P. When the spacing of an interrogator pulse pair varies from the nominal value by up to plus or minus 1 microsecond, the receiver sensitivity shall not be reduced by more than 1 dB.
- iv) Load limiting

- A. DME/N. When transponder loading exceeds 90 per cent of the maximum transmission rate, the receiver sensitivity shall be automatically reduced in order to limit the transponder replies, so as to ensure that the maximum permissible transmission rate is not exceeded. (The available range of sensitivity reduction shall be at least 50 dB.)
 - B. DME/P. To prevent transponder overloading the transponder shall automatically limit its replies, so as to ensure that the maximum transmission rate is not exceeded. If the receiver sensitivity reduction is implemented to meet this requirement, it shall be applied to the IA mode only and shall not affect the FA mode.
- v) Noise. When the receiver is interrogated at the power densities specified in 23.1.3.5 (d) (2) (iii) (A) above to produce a transmission rate equal to 90 per cent of the maximum, the noise generated pulse pairs shall not exceed 5 per cent of the maximum transmission rate.
- vi) Bandwidth
- A. The minimum permissible bandwidth of the receiver shall be such that the transponder sensitivity level shall not deteriorate by more than 3 dB when the total receiver drift is added to an incoming interrogation frequency drift of plus or minus 100 kHz.
 - B. DME/N. The receiver bandwidth shall be sufficient to allow compliance with 23.1.3.5 (c) (1) (iii) above when the input signals are those specified in 23.1.3.5 (e) (1) (iii) below.
 - C. DME/P — IA mode. The receiver bandwidth shall be sufficient to allow compliance 23.1.3.5 (c) (1) (iii) above when the input signals are those specified in 23.1.3.5 (c) (1) (iii) below. The 12 dB bandwidth shall not exceed 2 MHz and the 60 dB bandwidth shall not exceed 10 MHz.
 - D. DME/P — FA mode. The receiver bandwidth shall be sufficient to allow compliance with 23.1.3.5 (c) (1) (iii) above when the input signals are those specified in 23.1.3.5 (e) (1) (iii) below. The 12 dB bandwidth shall not exceed 6 MHz and the 60 dB bandwidth shall not exceed 20 MHz.
 - E. Signals greater than 900 kHz removed from the desired channel nominal frequency and having power densities up to the values specified in 23.1.3.5 (d) (3) (iii) for DME/N and 23.1.3.5 (d) (3) (iv) for DME/P shall not trigger the transponder. Signals arriving at the intermediate frequency shall be suppressed at least 80 dB. All other spurious response or signals within the 960 MHz to 1 215 MHz band and image frequencies shall be suppressed at least 75 dB.
- vii) Recovery time. Within 8 microseconds of the reception of a signal between 0 dB and 60 dB above minimum sensitivity level, the minimum sensitivity level of the transponder to a desired signal shall be within 3 dB of the value obtained in the absence of signals. This requirement shall be met with echo suppression circuits, if any, rendered inoperative. The 8 microseconds are to be measured between the half voltage points on the leading edges of the two signals, both of which conform in shape, with the specifications in 23.1.3.5 (e) (1) (iii) below.
- viii) Spurious radiations. Radiation from any part of the receiver or allied circuits shall meet the requirements stated in 23.1.3.5 (d) (3) (vi) above.
- ix) CW and echo suppression

- A. CW and echo suppression shall be adequate for the sites at which the transponders will be used.
- x) Protection against interference
 - A. Protection against interference outside the DME frequency band shall be adequate for the sites at which the transponders will be used.
- (3) Decoding
 - i) The transponder shall include a decoding circuit such that the transponder can be triggered only by pairs of received pulses having pulse duration and pulse spacings appropriate to interrogator signals as described in 23.1.3.5 (e) (1) (iii) and 23.1.3.5 (e) (1) (iv) below.
 - ii) The decoding circuit performance shall not be affected by signals arriving before, between, or after, the constituent pulses of a pair of the correct spacing.
 - iii) ‡DME/N — Decoder rejection. An interrogation pulse pair with a spacing of plus or minus 2 microseconds, or more, from the nominal value and with any signal level up to the value specified in 23.1.3.5 (d) (2) (iii) (C) shall be rejected such that the transmission rate does not exceed the value obtained when interrogations are absent.
 - iv) DME/P— Decoder rejection. An interrogation pulse pair with a spacing of plus or minus 2 microseconds, or more, from the nominal value and with any signal level up to the value specified in 23.1.3.5.4.2.3.4 shall be rejected such that the transmission rate does not exceed the value obtained when interrogations are absent.
- (4) Time delay
 - i) When a DME is associated only with a VHP facility, the time delay shall be the interval from the half voltage point on the leading edge of the second constituent pulse of the interrogation pair and the half voltage point on the leading edge of the second constituent pulse of the reply transmission. This delay shall be consistent with the following table, when it is desired that aircraft interrogators are to indicate distance from the transponder site.

Channel suffix	Operating mode	Pulse pair spacing (μ s)		Time delay (μ s)	
		Interrogation	Reply	1st pulse timing	2nd pulse timing
X	DME/N	12	12	50	50
	DME/P IA M	12	12	50	–
	DME/P FA M	18	12	56	–
Y	DME/N	36	30	56	50
	DME/P IA M	36	30	56	–
	DME/P FA M	42	30	62	–
W	DME/N	–	–	–	–
	DME/P IA M	24	24	50	–

	DME/P FA M	30	24	56	–
Z	DME/N	–	–	–	–
	DME/P IA M	21	15	56	–
	DME/P FA M	27	15	62	–

Note 1.— W and X are multiplexed on the same frequency.

Note 2.— Z and Y are multiplexed on the same frequency.

- ii) When a DME is associated with an MLS angle facility, the time delay shall be the interval from the half voltage point on the leading edge of the first constituent pulse of the interrogation pair and the half voltage point on the leading edge of the first constituent pulse of the reply transmission. This delay shall be 50 microseconds for mode X channels and 56 microseconds for mode Y channels, when it is desired that aircraft interrogators are to indicate distance from the transponder site.
 - A. For DME/P transponders, no time delay adjustment shall be permitted.
 - iii) For the DME/N the transponder time delay shall be capable of being set to an appropriate value between the nominal value of the time delay minus 15 microseconds and the nominal value of the time delay, to permit aircraft interrogators to indicate zero distance at a specific point remote from the transponder site.
 - A. DME/N. The time delay shall be the interval from the half voltage point on the leading edge of the first constituent pulse of the interrogation pair and the half voltage point on the leading edge of the first constituent pulse of the reply transmission.
 - B. DME/P — IA mode. The time delay shall be the interval from the half voltage point on the leading edge of the first constituent pulse of the interrogation pulse pair to the half voltage point on the leading edge of the first constituent pulse of the reply pulse pair.
 - C. DME/P — FA mode. The time delay shall be the interval from the virtual origin of the first constituent pulse of the interrogation pulse pair to the virtual origin of the first constituent pulse of the reply pulse pair. The time of arrival measurement points shall be within the partial rise time of the first constituent pulse of the pulse pair in each case.
 - D. DME/N. Transponders shall be sited as near to the point at which zero indication is required as is practicable.
- (5) Accuracy
- i) DME/N. The transponder shall not contribute more than plus or minus 1 microsecond (150 m (500 ft)) to the over-all system error.
 - A. DME/N. The contribution to the total system error due to the combination of the transponder errors, transponder location coordinate errors, propagation effects and random pulse interference effects shall be not greater than plus or minus 340 m (0.183 NM) plus 1.25 per cent of distance measure.

Note.— This error contribution limit includes errors from all causes except the airborne equipment, and assumes that the airborne equipment measures time delay based on the first constituent pulse of a pulse pair.

- B. DME/N. The combination of the transponder errors, transponder location coordinate errors, propagation effects and random pulse interference effects shall not contribute more than plus or minus 185 m (0.1 NM) to the overall system error.

Note. — This error contribution limit includes errors from all causes except the airborne equipment, and assumes that the airborne equipment measures time delay based on the first constituent pulse of a pulse pair.

- ii) \pm DME/N. A transponder associated with a landing aid shall not contribute more than plus or minus 0.5 microsecond (75 m (250 ft)) to the over-all system error.
 - iii) DME/P — FA mode
 - A. Accuracy standard 1. The transponder shall not contribute more than plus or minus 10m (plus or minus 33 ft) PFE and plus or minus 8 m (plus or minus 26 ft) CMN to the over-all system error.
 - B. Accuracy standard 2. The transponder shall not contribute more than plus or minus 5 m (plus or minus 23 ft) PFE and plus or minus 5 m (plus or minus 23 ft) CMN to the over-all system error.
 - iv) DME/P — IA mode. The transponder shall not contribute more than plus or minus 15m (plus or minus 50 ft) PFE and plus or minus 10 m (plus or minus 33 ft) CMN to the over-all system error.
 - v) When a DME is associated with an MLS angle facility, the above accuracy shall include the error introduced by the first pulse detection due to the pulse spacing tolerances.
- (6) Efficiency
- i) The transponder reply efficiency shall be at least 70 per cent for DME/N and DME/P (IA mode) and 80 per cent for DME/P (FA mode) at all values of transponder loading up to the loading corresponding to 23.1.3.5 (c) (5) above and at the minimum sensitivity level specified in 23.1.3.5 (d) (2) (iii) (A) and 23.1.3.5 (d) (2) (iii) (E) above.

- ii) Transponder dead time. The transponder shall be rendered inoperative for a period normally not to exceed 60 microseconds after a valid interrogation decode has occurred. In extreme cases when the geographical site of the transponder is such as to produce undesirable reflection problems, the dead time may be increased but only by the minimum amount necessary to allow the suppression of echoes for DME/N and DME/P IA mode.
 - A. In DME/P the IA mode dead time shall not blank the FA mode channel and vice versa.
- (7) Monitoring and control
 - i) Means shall be provided at each transponder site for the automatic monitoring and control of the transponder in use.
 - ii) DME/N monitoring action
 - A. In the event that any of the conditions specified in 23.1.3.5 (d) (7) (ii) (B) below occur, the monitor shall cause the following action to take place:
 - * a suitable indication shall be given at a control point;
 - * the operating transponder shall be automatically switched off; and
 - * the standby transponder, if provided, shall be automatically placed in operation.
 - B. The monitor shall cause the actions specified in 23.1.3.5 (d) (7) (ii) (A) above if:
 - * the transponder delay differs from the assigned value by 1 microsecond (150 m (500 ft)) or more;
 - * in the case of a DME/N associated with a landing aid, the transponder delay differs from the assigned value by 0.5 microsecond (75 m (250 ft)) or more.
 - C. The monitor shall cause the actions specified in 23.1.3.5 (d) (7) (ii) (A) above if the spacing between the first and second pulse of the transponder pulse pair differs from the nominal value specified in the table following 23.1. 3.5 (d) (4) (i) above by 1 microsecond or more.
 - D. The monitor shall also cause a suitable indication to be given at a control point if any of the following conditions arise:
 - * a fall of 3 dB or more in transponder transmitted power output;
 - * a fall of 6 dB or more in the minimum transponder receiver sensitivity (provided that this is not due to the action of the receiver automatic gain reduction circuits);
 - * the spacing between the first and second pulse of the transponder reply pulse pair differs from the normal value specified in 23.1.3.5 (d) (1) (iv) above by 1 microsecond or more;
 - * variation of the transponder receiver and transmitter frequencies beyond the control range of the reference circuits (if the operating frequencies are not directly crystal controlled).
 - E. Means shall be provided so that any of the conditions and malfunctioning enumerated in 23.1.3.5.4.7.2.2, 23.1.3.5.4.7.2.3 and 23.1.3.5.4.7.2.4 above which are monitored can persist for a certain period before the monitor takes action. This period shall be as low as practicable, but shall not exceed 10 seconds, consistent with the need for avoiding interruption, due to transient effects, of the service provided by the transponder.
 - F. 23.1.3.5.4.7.2.6 The transponder shall not be triggered more than 120 times per second for either monitoring or automatic frequency control purposes, or both.

- iii) DME/P monitoring action

- A. The monitor system shall cause the transponder radiation to cease and provide a warning at a control point if any of the following conditions persist for longer than the period specified:
- * there is a change in transponder PFE that exceeds the limits specified in either 23.1.3.5 (d) (5) (ii) or 23.1.3.5 (d) (5) (ii) (A) above for more than one second. If the FA mode limit is exceeded, but the IA mode limit is maintained, the IA mode may remain operative;
 - * there is a reduction in the effective radiated power to less than that necessary to satisfy the requirements specified in 23.1.3.5 (d) (1) (v) (C) above for a period of more than one second;
 - * there is a reduction of 3 dB or more in the transponder sensitivity necessary to satisfy the requirements specified in 23.1.3.5 (d) (2) (iii) above for a period of more than five seconds in FA mode and ten seconds in IA mode (provided that this is not due to the action of the receiver automatic sensitivity reduction circuits);
 - * the spacing between the first and second pulse of the transponder reply pulse pair differs from the value specified in the table in 23.1.3.5 (d) (4) (i) above by 0.25 microsecond or more for a period of more than one second.
- B. The monitor shall cause a suitable indication to be given at a control point if there is an increase above 0.3 microseconds or a decrease below 0.2 microseconds of the reply pulse partial rise time which persists for more than one second.
- C. The period during which erroneous guidance information is radiated shall not exceed the periods specified in 23.1.3.5 (d) (7) (iii) (A) above. Attempts to clear a fault by resetting the primary ground equipment or by switching to standby ground equipment, if fitted, shall be completed within this time. If the fault is not cleared within the time allowed, the radiation shall cease. After shutdown, no attempt shall be made to restore service until a period of 20 seconds has elapsed.
- D. The transponder shall not be triggered for monitoring purposes more than 120 times per second in the LA mode and 150 times per second in the FA mode.
- E. DME/N and DME/P monitor failure. Failure of any part of the monitor itself shall automatically produce the same results as the malfunctioning of the element being monitored.

(e) Technical characteristics of interrogator

- (1) Transmitter
- i) Frequency of operation. The interrogator shall transmit on the interrogation frequency appropriate to the assigned DME channel (see 23.1.3.5.3.3.3 above).
 - ii) Frequency stability. The radio frequency of operation shall not vary more than plus or minus 100 kHz from the assigned value.
 - iii) Pulse shape and spectrum. The following shall apply to all radiated pulses:
Pulse rise time.

- A. DME/N. Pulse rise time shall not exceed 3 micro-seconds.
- B. DME/P. Pulse rise time shall not exceed 1.6 microseconds. For the FA mode, the pulse shall have a partial rise time of 0.25 plus or minus 0.05 microsecond. With respect to the FA mode and accuracy standard 1, the slope of the pulse in the partial rise time shall not vary by more than plus or minus 20 per cent. For accuracy standard 2 the slope shall not vary by more than plus or minus 10 per cent.
- C. DME/P. Pulse rise time shall not exceed 1.2 microseconds.

- D. Pulse duration shall be 3.5 microseconds plus or minus 0.5 microsecond.
 - E. Pulse decay time shall nominally be 2.5 microseconds, but shall not exceed 3.5 microseconds.
 - F. The instantaneous amplitude of the pulse shall not, at any instant between the point of the leading edge which is 95 per cent of maximum amplitude and the point of the trailing edge which is 95 per cent of the maximum amplitude, fall below a value which is 95 per cent of the maximum voltage amplitude of the pulse.
 - G. The spectrum of the pulse modulated signal shall be such that at least 90 per cent of the energy in each pulse shall be within 0.5 MHz in a band centred on the nominal channel frequency.
 - H. To ensure proper operation of the thresholding techniques, the instantaneous magnitude of any pulse turn-on transients which occur in time prior to the virtual origin shall be less than one per cent of the pulse peak amplitude. Initiation of the turn-on process shall not commence sooner than 1 microsecond prior to the virtual origin.
- iv) Pulse spacing
- A. The spacing of the constituent pulses of transmitted pulse pairs shall be as given in the table in 23.1.3.5.4.4.1 above.
 - B. DME/N. The tolerance on the pulse spacing shall be plus or minus 0.5 microsecond.
 - C. DME/N. The tolerance on the pulse spacing shall be plus or minus 0.25 microsecond.
 - D. DME/P. The tolerance on the pulse spacing shall be plus or minus 0.25 microsecond.
 - E. The pulse spacing shall be measured between the half voltage points on the leading edges of the pulses.
- v) Pulse repetition frequency
- A. The pulse repetition frequency shall be as specified in 23.1.3.5 (c) (4) above.
 - B. The variation in time between successive pairs of interrogation pulses shall be sufficient to prevent false lock-on.
 - C. DME/P. In order to achieve the system accuracy specified in 23.1.3.5 (c) (1) (iii) (D) above, the variation in time between successive pairs of interrogation pulses shall be sufficiently random to decorrelate high frequency multipath errors.
- vi) Spurious radiation. During intervals between transmission of individual pulses, the spurious pulse power received and measured in a receiver having the same characteristics of a DME transponder receiver, but tuned to any DME interrogation or reply frequency, shall be more than 50 dB below the peak pulse power received and measured in the same receiver tuned to the interrogation frequency in use during the transmission of the required pulses. This provision shall apply to all spurious pulse transmissions. The spurious CW power radiated from the interrogator on any DME interrogation or reply frequency shall not exceed 20 microwatts (minus 47 dBW).
- vii) The spurious pulse power received and measured under the conditions stated in 23.1.3.5 (e) (1) (vi) above shall be 80 dB below the required peak pulse power received.
- viii) DME/P. The peak effective radiated power (ERP) shall not be less than that required to ensure the power densities in 23.1.3.5 (d) (2) (iii) (A) above under all operational weather conditions.

- (2) Time delay
- i) The time delay shall be consistent with the table in 23.1.3.5 (d) (4) (i) above.
 - ii) DME/N. The time delay shall be the interval between the time of the half voltage point on the leading edge of the second constituent interrogation pulse and the time at which the distance circuits reach the condition corresponding to zero distance indication.
 - iii) DME/N. The time delay shall be the interval between the time of the half voltage point on the leading edge of the first constituent interrogation pulse and the time at which the distance circuits reach the condition corresponding to zero distance indication.
 - iv) DME/P — IA mode. The time delay shall be the interval between the time of the half voltage point on the leading edge of the first constituent interrogation pulse and the time at which the distance circuits reach the condition corresponding to zero distance indication.
 - v) DME/P — FA mode. The time delay shall be the interval between the virtual origin of the leading edge of the first constituent interrogation pulse and the time at which the distance circuits reach the condition corresponding to zero distance indication. The time of arrival shall be measured within the partial rise time of the pulse.
- (3) Receiver
- i) Frequency of operation. The receiver centre frequency shall be the transponder frequency appropriate to the assigned DME operating channel.
 - ii) Receiver sensitivity
 - A. DME/N. The airborne equipment sensitivity shall be sufficient to acquire and provide distance information to the accuracy specified in 23.1.3.5 (e) (4) below for the signal power density specified in 23.1.3.5 (d) (1) (v) (B) above.
 - B. DME/P. The airborne equipment sensitivity shall be sufficient to acquire and provide distance information to the accuracy specified in 23.1.3.5 (e) (4) (ii) and 23.1.3.5 (e) (4) (iii) below for the signal power densities specified in 23.1.3.5 (d) (1) (v) (C) above.
 - C. DME/N, The performance of the interrogator shall be maintained when the power density of the transponder signal at the interrogator antenna is between the minimum values given in 23.1.3.5 (d) (1) (v) above and a maximum of minus 18 dBW/m².
 - D. DME/P. The performance of the interrogator shall be maintained when the power density of the transponder signal at the interrogator antenna is between the minimum values given in 23.1.3.5 (d) (1) (v) and a maximum of minus 18 dBW/m².
 - iii) Bandwidth
 - A. DME/N. The receiver bandwidth shall be sufficient to allow compliance with 23.1.3.5 (d) (1) (iii), when the input signals are those specified in 23.1.3.5 (d) (1) (iii).

- B. DME/P — 1A mode. The receiver bandwidth shall be sufficient to allow compliance with 23.1.3.5 (c) (1) (iii) when the input signals are those specified in 23.1.3.5 (d) (1) (iii). The 12-dB bandwidth shall not exceed 2 MHz and the 60-dB bandwidth shall not exceed 10 MHz.
 - C. DME/P — FA mode. The receiver bandwidth shall be sufficient to allow compliance with 23.1.3.5 (c) (1) (iii) when the input signals are those specified in 23.1.3.5 (c) (1) (iii). The 12-dB bandwidth shall not exceed 6 MHz and the 60-dB bandwidth shall not exceed 20 MHz.
- iv) Interference rejection
- A. When there is a ratio of desired to undesired co-channel DME signals of at least 8 dB at the input terminals of the airborne receiver, the interrogator shall display distance information and provide unambiguous identification from the stronger signal.
 - B. DME/N. DME signals greater than 900 kHz removed from the desired channel nominal frequency and having amplitudes up to 42 dB above the threshold sensitivity shall be rejected.
 - C. DME/P. DME signals greater than 900 kHz removed from the desired channel nominal frequency and having amplitudes up to 42 dB above the threshold sensitivity shall be rejected.
- v) Decoding
- A. The interrogator shall include a decoding circuit such that the receiver can be triggered only by pairs of received pulses having pulse duration and pulse spacings appropriate to transponder signals as described in 23.1.3.5 (d) (1) (iv).
 - B. DME/N — Decoder rejection. A reply pulse pair with a spacing of plus or minus 2 microseconds, or more, from the nominal value and with any signal level up to 42 dB above the receiver sensitivity shall be rejected.
 - C. DME/P — Decoder rejection. A reply pulse pair with a spacing of plus or minus 2 microseconds, or more, from the nominal value and with any signal level up to 42 dB above the receiver sensitivity shall be rejected.
- (4) Accuracy
- i) DME/N. The interrogator shall not contribute more than plus or minus 315 m (plus or minus 0.17 NM) to the over-all system error.
 - ii) DME/P — IA mode. The interrogator shall not contribute more than plus or minus 30 m (plus or minus 100 ft) to the over-all system PFE and not more than plus or minus 15m (plus or minus 50 ft) to the over-all system CMN.
 - iii) DME/P — FA mode
 - A. Accuracy standard 1. The interrogator shall not contribute more than plus or minus 15 m (plus or minus 50 ft) to the over-

- all system PFE and not more than plus or minus 10m (plus or minus 33 ft) to the over-all system CMN.
- B. Accuracy standard 2. The interrogator shall not contribute more than plus or minus 7 m (plus or minus 23 ft) to the over-all system PFE and not more than plus or minus 7 m (plus or minus 23 ft) to the overall system CMN.
- iv) DME/P. The interrogator shall achieve the accuracy specified in 23.1.3.5 (c) (1) (iii) (A) with a system efficiency of 50 per cent or more.

23.1.3.6 SPECIFICATION FOR EN-ROUTE VHF MARKER BEACONS (75MHZ)

(a) Equipment

- (1) Frequencies. The emissions of an en-route VHF marker beacon shall have a radio frequency of 75 MHz plus or minus 0.005 per cent.
- (2) Characteristics of emissions
- i) Radio marker beacons shall radiate an uninterrupted carrier modulated to a depth of not less than 95 per cent or more than 100 per cent. The total harmonic content of the modulation shall not exceed 15 per cent.
- ii) The frequency of the modulating tone shall be 3 000 Hz plus or minus 75 Hz.
- iii) The radiation shall be horizontally polarized.
- iv) Identification. If a coded identification is required at a radio marker beacon, the modulating tone shall be keyed so as to transmit dots or dashes or both in an appropriate sequence. The mode of keying shall be such as to provide a dot-and- dash duration together with spacing intervals corresponding to transmission at a rate equivalent to approximately six to ten words per minute. The carrier shall not be interrupted during identification.
- v) Coverage and radiation pattern

Note.— The coverage and radiation pattern of marker beacons will ordinarily be established by Contracting States on the basis of operational requirements, taking into account recommendations of regional meetings

The most desirable radiation pattern would be one that:

A. *in the case of fan marker beacons, results in lamp operation only when the aircraft is within a rectangular parallelepiped, symmetrical about the vertical line through the marker beacon and with the major and minor axes adjusted in accordance with the flight path served;*

B. *in the case of a Z marker beacon, results in lamp operation only when the aircraft is within a cylinder, the axis of which is the vertical line through the marker beacons.*

In practice, the production of such patterns is impracticable and a compromise radiation pattern is necessary. In Attachment C, antenna systems currently in use and which have proved generally satisfactory are described for guidance. Such designs and any new designs providing a closer approximation to the most desirable radiation pattern outlined above will normally meet operational requirements

- vi) Determination of coverage. The limits of coverage of marker beacons shall be determined on the basis of the field strength specified in 23.1.3.1 (g) (3) (ii).

- vii) Radiation pattern. The radiation pattern of a marker beacon normally shall be such that the polar axis is vertical, and the field strength in the pattern is symmetrical about the polar axis in the plane or planes containing the flight paths for which the marker beacon is intended.
- (3) Monitoring. For each marker beacon, suitable monitoring equipment shall be provided which will show at an appropriate location:
 - i) a decrease in radiated carrier power below 50 per cent of normal;
 - ii) a decrease of modulation depth below 70 per cent;
 - iii) a failure of keying.

23.1.3.7 REQUIREMENTS FOR THE GLOBAL NAVIGATION SATELLITE SYSTEM (GNSS)

(a) Definitions

- (1) **Aircraft-based augmentation system (ABAS).** An augmentation system that augments and/or integrates the information obtained from the other GNSS elements with information available on board the aircraft.
- (2) **Alert.** An indication provided to other aircraft systems or annunciation to the pilot to identify that an operating parameter of a navigation system is out of tolerance.
- (3) **Alert limit.** For a given parameter measurement, the error tolerance not to be exceeded without issuing an alert.
- (4) **Antenna port.** A point where the received signal power is specified. For an active antenna, the antenna port is a fictitious point between the antenna elements and the antenna pre-amplifier. For a passive antenna, the antenna port is the output of the antenna itself.
- (5) **Axial ratio.** The ratio, expressed in decibels, between the maximum output power and the minimum output power of an antenna to an incident linearly polarized wave as the polarization orientation is varied over all directions perpendicular to the direction of propagation.
- (6) **Channel of standard accuracy (CSA).** The specified level of positioning, velocity and timing accuracy that is available to any GLONASS user on a continuous, worldwide basis.
- (7) **Core satellite constellation(s).** The core satellite constellations are GPS and GLONASS.
- (8) **Global navigation satellite system (GNSS).** A worldwide position and time determination system that includes one or more satellite constellations, aircraft receivers and system integrity monitoring, augmented as necessary to support the required navigation performance for the intended operation.
- (9) **Global navigation satellite system (GLONASS).** The satellite navigation system operated by the Russian Federation.
- (10) **Global positioning system (GPS).** The satellite navigation system operated by the United States.
- (11) **GNSS position error.** The difference between the true position and the position determined by the GNSS receiver.

- (12) **Ground-based augmentation system (GBAS).** An augmentation system in which the user receives augmentation information directly from a ground-based transmitter,
- (13) **Integrity.** A measure of the trust that can be placed in the correctness of the information supplied by the total system. Integrity includes the ability of a system to provide timely and valid warnings to the user (alerts).
- (14) **Pseudo-range.** The difference between the time of transmission by a satellite and reception by a GNSS receiver multiplied by the speed of light in a vacuum, including bias due to the difference between a GNSS receiver and satellite time reference.
- (15) **Satellite-based augmentation system (SBAS).** A wide coverage augmentation system in which the user receives augmentation information from a satellite-based transmitter.
- (16) **Standard positioning service (SPS).** The specified level of positioning, velocity and timing accuracy that is available to any global positioning system (GPS) user on a continuous, worldwide basis.
- (17) **Time-to-alert.** The maximum allowable time elapsed from the onset of the navigation system being out of tolerance until the equipment enunciates the alert.

(b) General

- (1) Functions
 - i) The GNSS shall provide position and time data to the aircraft.
- (2) GNSS elements
 - i) The GNSS navigation service shall be provided using various combinations of the following elements installed on the ground, on satellites and/or on board the aircraft:
 - A. Global Positioning System (GPS) that provides the Standard Positioning Service (SPS) as defined in 23.1.3.7 (c) (1);
 - B. Global Navigation Satellite System (GLONASS) that provides the Channel of Standard Accuracy (CSA) navigation signal as defined 23.1.3.7 (c) (2);
 - C. aircraft-based augmentation system (ABAS) as defined in 23.1.3.7 (c) (3);
 - D. satellite-based augmentation system (SBAS) as defined in 23.1.3.7 (c) (4) ground-based augmentation system (GBAS) as defined in 23.1.3.7 (c) (5); and
 - E. ground-based regional augmentation system (GRAS) as defined in 3.7.3.5; and
 - F. aircraft GNSS receiver as defined in 23.1.3.7 (c) (6).
- (3) Space and time reference

- i) Space reference. The position information provided by the GNSS to the user shall be expressed in terms of the World Geodetic System — 1984 (WGS-84) geodetic reference datum.
 - ii) Time reference. The time data provided by the GNSS to the user shall be expressed in a time scale that takes the Universal Time Coordinated (UTC) as reference.
- (4) Signal-in-space performance
- i) The combination of GNSS elements and a fault-free GNSS user receiver shall meet the signal-in-space requirements defined in Table 23.1.3.7.2.4.1 (located at the end of Subpart 23.1. 3.7).

(c) GNSS elements specifications

(1) GPS Standard Positioning Service (SPS) (LI)

- i) Space and control segment accuracy. The conditions specified in IS: 23.1.3.7, 3.1.3.1.1 shall apply.

A. Positioning accuracy. The GPS SPS position errors shall not exceed the following limits:

	Global average 95% of the time	Worst site 95% of the time
Position error	9 m (30 ft)	7 m (56 ft)
Position error	15 m (49 ft)	12 m (121 ft)

B. Time transfer accuracy. The GPS SPS time transfer errors shall not exceed 40 nanoseconds 95 per cent of the time.

C. Range domain accuracy. The range domain error shall not exceed the following limits:

D. range error of any satellite — 30 m (100 ft) with reliability specified in 23.1.3.7 (c) (1) (iii);

E. 95th percentile range rate error of any satellite — 0.006 m (0.02 ft) per second (global average);

F. 95th percentile range acceleration error of any satellite —0.002 m (0.006 ft) per second-squared (global average); and

G. 95th percentile range error for any satellite over all time differences between time of data generation and time of use of data — 7.8 m (26 ft) (global average).

- ii) Availability. The GPS SPS availability shall be as follows:

- ≥99 per cent horizontal service availability, average location (37 metre 95 per cent threshold)
- ≥99 per cent vertical service availability, average location (17metre 95 per cent threshold)
- ≥90 per cent horizontal service availability, worst-case location (37metre 95 per cent threshold)
- ≥90 per cent vertical service availability, worst-case location (17 metre 95 per cent threshold)

- iii) Reliability. The GPS SPS reliability shall be within the following limits:
 - A. reliability — at least 99.94 per cent (global average); and
 - B. reliability — at least 99.79 per cent (worst single point average).
- iv) Probability of major service failure. The probability that the user range error (URE) of any satellite will exceed 4.42 times the upper bound on the user range accuracy (URA) broadcast by that satellite without an alert received at the user receiver antenna within 10 seconds shall not exceed 1×10^{-5} per hour.

Note.— The different alert indications are described in the United States Department of Defense, Global Positioning System – Standard Positioning Service – Performance Standard, 4th Edition, September 2008, Subpart 2.3.4.

- v) Continuity. The probability of losing GPS SPS signal-in-space (SIS) availability from a slot of the nominal 24-slot constellation due to unscheduled interruption shall not exceed 2×10^{-4} per hour.
- vi) Coverage. The GPS SPS shall cover the surface of the earth up to an altitude of 3000 kilometres.
- vii) Radio frequency (RF) characteristics
 - A. Carrier frequency. Each GPS satellite shall broadcast an SPS signal at the carrier frequency of 1 575.42 MHz (GPS L1) using code division multiple access (CDMA).
 - B. Signal spectrum. The GPS SPS signal power shall be contained within a ± 12 MHz band (1 563.42 – 1 587.42 MHz) centred on the L1 frequency.
 - C. Polarization. The transmitted RF signal shall be right-hand (clockwise) circularly polarized.
 - D. Signal power level. Each GPS satellite shall broadcast SPS navigation signals with sufficient power such that, at all unobstructed locations near the ground from which the satellite is observed at an elevation angle of 5 degrees or higher, the level of the received RF signal at the output of a 3 dBi linearly-polarized antenna is within the range of -230 158dBW to -153 dBW for all antenna orientations orthogonal to the direction of propagation.
 - E. Modulation. The SPS L1 signal shall be bipolar phase shift key (BPSK) modulated with a pseudo random noise (PRN) 1.023 MHz coarse/acquisition (C/A) code. The C/A code sequence shall be repeated each millisecond. The transmitted PRN code sequence shall be the Modulo-2 addition of a 50 bits per second navigation message and the C/A code.

- viii) GPS time. GPS time shall be referenced to UTC (as maintained by the U.S. Naval Observatory).
- ix) Coordinate system. The GPS coordinate system shall be WGS-84.
- x) Navigation information. The navigation data transmitted by the satellites shall include the necessary information to determine:
 - A. satellite time of transmission;
 - B. satellite position;
 - C. satellite health;
 - D. satellite clock correction;
 - E. propagation delay effects;
 - F. time transfer to UTC; and
 - G. constellation status.

(2) GLONASS Channel of Standard Accuracy (CSA) (L1)

Note.— In this Subpart, the term GLONASS refers to all satellites in the constellation. Provisions relating only to GLONASS-M satellites are qualified accordingly.

- i) Space and control segment accuracy
 - A. Positioning accuracy. The GLONASS CSA position errors shall not exceed the following limits:
 - B. Time transfer accuracy. The GLONASS CSA time transfer errors shall not exceed 700 nanoseconds 95 per cent of the time.
 - C. Range domain accuracy. The range domain error shall not exceed the following limits:
 - D. range error of any satellite — 18 m (59.7 ft);
 - E. range rate error of any satellite — 0.02 m (0.07 ft) per second;
 - F. range acceleration error of any satellite — 0.007 m (0.023 ft) per second squared;
 - G. root-mean-square range error over all satellites — 6 m (19.9 ft).
- ii) Availability. The GLONASS CSA availability shall be as follows:
 - A. ≥99 per cent horizontal service availability, average location (12 m, 95 per cent threshold);
 - B. ≥99 per cent vertical service availability, average location (25 m, 95 per cent threshold);
 - C. ≥90 per cent horizontal service availability, worst-case location (12m,95 percent threshold);
 - D. ≥90 per cent vertical service availability, worst-case location (25 m, 95 per cent threshold).
- iii) Reliability. The GLONASS CSA reliability shall be within the following limits:
 - A. frequency of a major service failure — not more than three per year for the constellation (global average); and
 - B. reliability — at least 99.7 per cent (global average).
- iv) Coverage. The GLONASS CSA shall cover the surface of the earth up to an altitude of 2 000 km.
- v) RF characteristics

Note.— Detailed RF characteristics are specified in IS: 23.1.3.7, 3.2.1.1.

- A. **Carrier frequency.** Each GLONASS satellite shall broadcast CSA navigation signal at its own carrier frequency in the L1

(1.6 GHz) frequency band using frequency division multiple access (FDMA).

- B. **Signal spectrum.** GLONASS CSA signal power shall be contained within a ± 5.75 MHz band centred on each GLONASS carrier frequency.
- C. **Polarization.** The transmitted RF signal shall be right-hand circularly polarized.
- D. **Signal power level.** Each GLONASS satellite shall broadcast CSA navigation signals with sufficient power such that, at all unobstructed locations near the ground from which the satellite is observed at an elevation angle of 5 degrees or higher, the level of the received RF signal at the output of a 3dBi linearly polarized antenna is within the range of -231 dBW to -155.2 dBW for all antenna orientations orthogonal to the direction of propagation.

Modulation

- E. Each GLONASS satellite shall transmit at its carrier frequency the navigation RF signal using a BPSK- modulated binary train. The phase shift keying of the carrier shall be performed at p -radians with the maximum error ± 0.2 radian. The pseudo-random code sequence shall be repeated each millisecond.
- F. The modulating navigation signal shall be generated by the Modulo-2 addition of the following three binary signals:

ranging code transmitted at 511 kbits/s;

navigation message transmitted at 50 bits/s; and

100 Hz auxiliary meander sequence.

- vi) GLONASS time. GLONASS time shall be referenced to UTC (SU) (as maintained by the National Time Service of Russia).
- vii) Coordinate system. The GLONASS coordinate system shall be PZ-90.

Note.— Conversion from the PZ-90 coordinate system used by GLONASS to the WGS-84 coordinates is defined in IS: 23.1.3.7, 3.2.5.2.

- viii) Navigation information. The navigation data transmitted by the satellite shall include the necessary information to determine:
 - A. satellite time of transmission;
 - B. satellite position;
 - C. satellite health;
 - D. satellite clock correction;
 - E. time transfer to UTC; and
 - F. constellation status.

Note.— Structure and contents of data are specified in IS: 23.1.3.7, 3.2.1.2 and 3.2.1.3, respectively.

(3) Aircraft-based augmentation system (ABAS)

- i) Performance. The ABAS function combined with one or more of the other GNSS elements and both a fault-free GNSS receiver and fault-free aircraft system used for the ABAS function shall meet the requirements for accuracy, integrity, continuity and availability as stated in 23.1.3.7 (b) (4).

- (4) Satellite-based augmentation system (SBAS)
- i) Performance. SBAS combined with one or more of the other GNSS elements and a fault-free receiver shall meet the requirements for system accuracy, integrity, continuity and availability for the intended operation as stated in 23.1.3.7 (b) (4).
 - ii) Functions. SBAS shall perform one or more of the following functions:
 - A. Ranging: provide an additional pseudo-range signal with an accuracy indicator from a SBAS satellite (23.1.3.7 (c) (4) (ii) (A) and IS: 23.1.3.7, 3.5.7.2);
 - B. GNSS satellite status: determine and transmit the GNSS satellite health status (IS: 23.1.3.7, 3.5.7.3);
 - C. Basic differential correction: provide GNSS satellite ephemeris and clock corrections (fast and long-term) to be applied to the pseudo-range measurements from satellites (IS: 23.1.3.7, 3.5.7.4); and
 - D. Precise differential correction: determine and transmit the ionospheric corrections (IS: 23.1.3.7, 3.5.7.5).

Ranging

- A. Excluding atmospheric effects, the range error for the ranging signal from SBAS satellites shall not exceed 25 metres (82ft)(95 per cent).
 - B. The probability that the range error exceeds 150 metres(490ft) in any hour shall not exceed 10⁻⁵.
 - C. The probability of unscheduled outages of the ranging function from an SBAS satellite in any hour shall not exceed 10⁻³.
 - D. The range rate error shall not exceed 2 metres (6.6ft) per second.
 - E. The range acceleration error shall not exceed 0.019(0.06ft) metres per second-squared.
- iii) Service area. The SBAS service area shall be a defined area within an SBAS coverage area where SBAS meets the requirements of 23.1.3.7 (b) (4) and supports the corresponding approved operations.
- iv) RF characteristics

Note.— Detailed RF characteristics are specified in IS: 23.1.3.7, 3.5.2.

- A. Carrier frequency. The carrier frequency shall be 1575.42 MHz.
- B. Signal spectrum. At least 95 per cent of the broadcast power shall be contained within a ± 12 MHz band centred on the L1 frequency. The bandwidth of the signal transmitted by an SBAS satellite shall be at least 2.2 MHz.
- C. SBAS Satellite Signal power level.
- D. Each SBAS satellite shall broadcast navigation signals with sufficient power such that, at all unobstructed locations near the ground from which the satellite is observed at an elevation angle of 5 degrees or higher, the level of the received RF signal at the output of a 3 dBi linearly polarized antenna is within the range of -231 dBW to -153 dBW for all antenna orientations orthogonal to the direction of propagation.
- E. Each SBAS satellite placed in orbit after 31 December 2013 shall comply with the following requirements:
- F. The satellite shall broadcast navigation signals with sufficient power such that, at all unobstructed locations near the ground from which the satellite is observed at or above the minimum

- elevation angle for which a trackable GEO signal needs to be provided, the level of the received RF signal at the antenna port of the antenna specified in IS: 23.1.3.7, Table B-88, is at least -234.0 dBW.
- G. The minimum elevation angle used to determine GEO coverage shall not be less than 5 degrees for a user near the ground.
 - H. The level of a received SBAS RF signal at the antenna port of a 0 dBic antenna located near the ground shall not exceed -152.5 dBW.
 - I. The ellipticity of the broadcast signal shall be no worse than 2 dB for the angular range of $\pm 9.1^\circ$ from boresight.
 - J. Polarization. The broadcast signal shall be right-hand circularly polarized.
 - K. Modulation. The transmitted sequence shall be the Modulo-2 addition of the navigation message at a rate of 500 symbols per second and the 1 023 bit pseudo-random noise code. It shall then be BPSK-modulated onto the carrier at a rate of 1.023 megachips per second.
- v) SBAS network time (SNT). The difference between SNT and GPS time shall not exceed 50 nanoseconds.
 - vi) Navigation information. The navigation data transmitted by the satellites shall include the necessary information to determine:
 - A. SBAS satellite time of transmission;
 - B. SBAS satellite position;
 - C. corrected satellite time for all satellites;
 - D. corrected satellite position for all satellites;
 - E. ionospheric propagation delay effects;
 - F. user position integrity;
 - G. time transfer to UTC; and
 - H. service level status.

Note. — Structure and contents of data are specified in IS: 23.1.3.7, 3.5.3 and 3.5.4, respectively.

- (5) Ground-based augmentation system (GBAS) and ground-based regional augmentation system (GRAS)

Note 1. — Except where specifically annotated, GBAS Standards apply to GBAS and GRAS.

Note 2. — Except where specifically annotated, reference to approach with vertical guidance (APV) means APV-I and APV-II.

- i) Performance. GBAS combined with one or more of the other GNSS elements and a fault-free GNSS receiver shall meet the requirements for system accuracy, continuity, availability and integrity for the intended operation as stated in 23.1.3.7 (b) (4).

Note. — GBAS is intended to support all types of approach, landing, departure and surface operations and may support en-route and terminal operations. GRAS is intended to support en-route, terminal, non-precision approach, departure, and approach with vertical guidance. The following SARPs are developed to support Category I precision approach, approach with vertical guidance, and a GBAS positioning service. In order to achieve interoperability and enable efficient

spectrum utilization, it is intended that the data broadcast is the same for all operations.

- i) Functions. GBAS shall perform the following functions:
 - A. provide locally relevant pseudo-range corrections;
 - B. provide GBAS-related data;
 - C. provide final approach segment data;
 - D. provide predicted ranging source availability data; and
 - E. provide integrity monitoring for GNSS ranging sources.

- ii) Coverage
 - A. The GBAS coverage to support each Category I precision approach shall be as follows, except where topographical features dictate and operational requirements permit:
 - B. laterally, beginning at 140 m (450 ft) each side of the landing threshold point/fictitious threshold point (LTP/FTP) and projecting out ± 35 degrees either side of the final approach path to 28 km (15 NM) and ± 10 degrees either side of the final approach path to 37 km (20 NM); and
 - C. vertically, within the lateral region, up to the greater of 7 degrees or 1.75 promulgated glide path angle (GPA) above the horizontal with an origin at the glide path interception point (GPIP) and 0.45 GPA above the horizontal or to such lower angle, down to 0.30 GPA, as required, to safeguard the promulgated glide path intercept procedure. This coverage applies between 30 m (100 ft) and 3 000 m (10000 ft) Height above Threshold (HAT).

Note. — LTP/FTP and GPIP are defined in IS: 23.1.3.7, 3.6.4.5.1.

- D. For Category I precision approach, the data broadcast as specified in 23.1.3.7.3.5.4 shall extend down to 3.7 m (12 ft) above the runway surface.
 - E. The data broadcast shall be omnidirectional when required to support the intended applications.
 - F. GBAS positioning service. The GBAS positioning service area shall be that area where the data broadcast can be received and the positioning service meets the requirements of 23.1.3.7.2.4 and supports the corresponding approved operations.
- iii) Data broadcast characteristics

Note. — RF characteristics are specified in IS: 23.1.3.7, 3.6.2.

- A. Carrier frequency. The data broadcast radio frequencies used shall be selected from the radio frequencies in the band 108 to 117.975 MHz. The lowest assignable frequency shall be 108.025 MHz and the highest assignable frequency shall be 117.950 MHz. The separation between assignable frequencies (channel spacing) shall be 25 kHz.
 - B. Access technique. A time division multiple access (TDMA) technique shall be used with a fixed frame structure. The data broadcast shall be assigned one to eight slots.

- C. Modulation. GBAS data shall be transmitted as 3-bit symbols, modulating the data broadcast carrier by D8PSK, at a rate of 10500 symbols per second.
- D. Data broadcast RF field strength and polarization
- E. GBAS/H
- F. A horizontally polarized signal shall be broadcast.
- G. The effective radiated power (ERP) shall provide for a horizontally polarized signal with a minimum field strength of 215 microvolts per metre (-99 dBW/metres-squared) and a maximum field strength of 0.350 volts per metre (-35 dBW/metres-squared) within the GBAS coverage subpart. The field strength shall be measured as an average over the period of the synchronization and ambiguity resolution field of the burst. The RF phase offset between the HPOL and any VPOL components shall be such that the minimum signal power defined in IS: 23.13.7, 3.6.8.2.2.3 is achieved for HPOL users throughout the coverage subpart.
- H. GBAS/E.
- I. An elliptically polarized signal shall be broadcast whenever practical.
- J. When an elliptically polarized signal is broadcast, the horizontally polarized component shall meet the requirements in 23.1.3.7.3.5.4.4.1.2, and the effective radiated power (ERP) shall provide for a vertically polarized signal with a minimum field strength of 136 microvolts per metre (-103 dBW/m²) and a maximum field strength of 0.221 volts per metre (-39 dBW/m²) within the GBAS coverage subpart. The field strength shall be measured as an average over the period of the synchronization and ambiguity resolution field of the burst. The RF phase offset between the HPOL and VPOL components, shall be such that the minimum signal power defined in IS: 23.1.3.7, 3.6.8.2.2.3 is achieved for HPOL and VPOL users throughout the coverage subpart.

Note.— The minimum and maximum field strengths in 23.1.3.7.3.5.4.4.1.2 and 23.1.3.7.3.5.4.4.2.2 are consistent with a minimum receiver sensitivity of -87 dBm and minimum distance of 200 m (660 ft) from the transmitter antenna for a coverage range of 43 km (23 NM).

- K. Power transmitted in adjacent channels. The amount of power during transmission under all operating conditions when measured over a 25 kHz bandwidth centred on the *i*th adjacent channel shall not exceed the values shown in Table 23.1.3.7.3.5-1 (located at the end of Subpart 23.1.3.7).
 - L. Unwanted emissions. Unwanted emissions, including spurious and out-of-band emissions, shall be compliant with the levels shown in Table 23.1.3.7.3.5-1 (located at the end of Subpart 23.1.3.7). The total power in any VDB harmonic or discrete signal shall not be greater than -53 dBm.
- iv) Navigation information. The navigation data transmitted by GBAS shall include the following information:
- A. pseudo-range corrections, reference time and integrity data;
 - B. GBAS-related data;

- C. final approach segment data when supporting precision approach; and d) predicted ranging source availability data.

Note. — Structure and contents of data are specified in IS: 23.1.3.7, 3.6.3.

(6) Aircraft GNSS receiver

- i) The aircraft GNSS receiver shall process the signals of those GNSS elements that it intends to use as specified in IS: 23.1.3.7, 3.1 (for GPS), IS: 23.1.3.7, 3.2 (for GLONASS), IS: 23.1.3.7, 3.3 (for combined GPS and GLONASS), IS: 23.1.3.7, 3.5 (for SBAS) and IS: 23.1.3.7, 3.6 (for GBAS and GRAS).

(d) Resistance to interference

- (1) GNSS shall comply with performance requirements defined in 3.7.2.4 and IS: 23.1.3.7, 3.7 in the presence of the interference environment defined in IS: 23.1.3.7, 3.7.

Note.— GPS and GLONASS operating in the frequency band 1 559 – 1 610 MHz are classified by the ITU as providing a radio navigation satellite service (RNSS) and aeronautical radio navigation service (ARNS) and are afforded special spectrum protection status for RNSS. In order to achieve the performance objectives for precision approach guidance to be supported by the GNSS and its augmentations, RNSS/ARNS is intended to remain the only global allocation in the 1 559 – 1 610 MHz band and emissions from systems in this and adjacent frequency bands are intended to be tightly controlled by national and/or international regulation.

(e) Database

Note. — Provisions applicable to aeronautical data are provided in Parts 14, 15, 21 and 23 of LIBERIA Civil Aviation REGULATIONS.

- (1) Aircraft GNSS equipment that uses a database shall provide a means to:
- A. update the electronic navigation database; and
 - B. determine the Aeronautical Information Regulation and Control (AIRAC) effective dates of the aeronautical database.

Table 1 Signal-in-space phase performance requirements.

Typical operation	Accuracy horizontal 95% (Notes 1 and 3)	Accuracy vertical 95% (Notes 1 and 3)	Integrity (Note 2)	Time-to-alert (Note 3)	Continuity (Note 4)	Availability (Note 5)
En-route	3.7 km (2.0 NM) (Note 6)	N/A	$1 - 1 \times 10^{-7}/h$	5 min	$1 - 1 \times 10^{-4}/h$ to $1 - 1 \times 10^{-8}/h$	0.99 to 0.99999
En-route, Terminal	0.74 km (0.4 NM)	N/A	$1 - 1 \times 10^{-7}/h$	15 s	$1 - 1 \times 10^{-4}/h$ to $1 - 1 \times 10^{-8}/h$	0.99 to 0.99999
Initial approach, Intermediate approach, Non-precision approach (NPA), Departure	220 m (720 ft)	N/A	$1 - 1 \times 10^{-7}/h$	10 s	$1 - 1 \times 10^{-4}/h$ to $1 - 1 \times 10^{-8}/h$	0.99 to 0.99999
Approach operations with vertical guidance (APV-I)	16.0 m (52 ft)	20 m (66 ft)	$1 - 2 \times 10^{-7}$ per approach	10 s	$1 - 8 \times 10^{-6}$ in any 15 s	0.99 to 0.99999
Approach operations with vertical guidance (APV-II)	16.0 m (52 ft)	8.0 m (26 ft)	$1 - 2 \times 10^{-7}$ per approach	6 s	$1 - 8 \times 10^{-6}$ in any 15 s	0.99 to 0.99999
Category I precision approach (Note 8)	16.0 m (52 ft)	6.0 m to 4.0 m (20 ft to 13 ft) (Note 7)	$1 - 2 \times 10^{-7}$ per approach	6 s	$1 - 8 \times 10^{-6}$ in any 15 s	0.99 to 0.99999

NOTES.—

The 95th percentile values for GNSS position errors are those required for the intended operation at the lowest height above threshold (HAT), if applicable. Detailed requirements are specified in **IS: 23.1.3.7**

The definition of the integrity requirement includes an alert limit against which the requirement can be assessed. These alert limits are:

Operation	Horizontal alert limit	Vertical alert limit
En-route/continental	7.4 km (4 NM)	N/A
En-route (continental)	3.7 km (2 NM)	N/A
Initial approach	1.85 km (1 NM)	N/A
Intermediate approach	556 m (0.3 NM)	N/A
Non-precision approach	40 m (130 ft)	50 m (164 ft)
Category I precision approach	40 m (130 ft)	20.0 m (66 ft)
Category II precision approach	40 m (130 ft)	10.0 m to 7.5 m (33 ft to 25 ft)

The accuracy and time-to-alert requirements include the nominal performance of a fault-free receiver.

Ranges of values are given for the continuity requirement for en-route, terminal, initial approach, NPA and departure operations, as this requirement is dependent upon several factors including the intended operation, traffic density, complexity of airspace and availability of alternative navigation aids. The lower value given is the minimum requirement for areas with low traffic density and airspace complexity. The higher value given is appropriate for areas with high traffic density and airspace complexity.

(see Attachment D, 3.4.2). Continuity requirements for APV and Category I operations apply to the average risk (over time) of loss of service, normalized to a 15-second exposure time (see Attachment D, 3.4.3).

Table 1 GBAS broadcast power transmitted in adjacent channels

Channel	Relative power	Maximum power
t		m
:		3m
:		3m
:	3c	dBm
nt	1Bc	dBm
nt	c	3m
nt	c	3m
nt and beyond	c	3m

NOTES.—

The maximum power applies if the authorized transmitter power exceeds 150 W.
The relationship is linear between single adjacent points designated by the adjacent channels identified above.

Table 2 GBAS broadcast unwanted emissions

Frequency	Relative unwanted emission level (Note 2)	Maximum unwanted emission level (Note 1)
9 kHz to 150 kHz	-93 dBc (Note 3)	-55 dBm/1 kHz (Note 3)
150 kHz to 30 MHz	-103 dBc (Note 3)	-55 dBm/10 kHz (Note 3)
30 MHz to 106.125 MHz	-115 dBc	-57 dBm/100 kHz
106.425 MHz	-113 dBc	-55 dBm/100 kHz
107.225 MHz	-105 dBc	-47 dBm/100 kHz
107.625 MHz	-101.5 dBc	-53.5 dBm/10 kHz
107.825 MHz	-88.5 dBc	-40.5 dBm/10 kHz
107.925 MHz	-74 dBc	-36 dBm/1 kHz
107.9625 MHz	-71 dBc	-33 dBm/1 kHz
107.975 MHz	-65 dBc	-27 dBm/1 kHz
118.000 MHz	-65 dBc	-27 dBm/1 kHz
118.0125 MHz	-71 dBc	-33 dBm/1 kHz
118.050 MHz	-74 dBc	-36 dBm/1 kHz
118.150 MHz	-88.5 dBc	-40.5 dBm/10 kHz
118.350 MHz	-101.5 dBc	-53.5 dBm/10 kHz

118.750 MHz	-105 dBc	-47 dBm/100 kHz
119.550 MHz	-113 dBc	-55 dBm/100 kHz
19.850 MHz to 1 GHz	-115 dBc	-57 dBm/100 kHz
1 GHz to 1.7 GHz	-115 dBc	-47 dBm/1 MHz

NOTES.—

1. The maximum unwanted emission level (absolute power) applies if the authorized transmitter power exceeds 150 W.
2. The relative unwanted emission level is to be computed using the same bandwidth for desired and unwanted signals. This may require conversion of the measurement for unwanted signals done using the bandwidth indicated in the maximum unwanted emission level column of this table.
3. This value is driven by measurement limitations. Actual performance is expected to be better.
4. The relationship is linear between single adjacent points designated by the adjacent channels identified above.

23.1.3.8 RESERVED

23.1.3.9 SYSTEM CHARACTERISTICS OF AIRBORNE ADF RECEIVING SYSTEMS

(a) Accuracy of bearing indication

- (1) The bearing given by the ADF system shall not be in error by more than plus or minus 5 degrees with a radio signal from any direction having a field strength of 70 microvolts per metre or more radiated from an LF/MF NDB or locator operating within the tolerances permitted by this Annex and in the presence also of an unwanted signal from a direction 90 degrees from the wanted signal and:
 - i) on the same frequency and 15 dB weaker; or
 - ii) plus or minus 2 kHz away and 4 dB weaker; or
 - iii) plus or minus 6 kHz or more away and 55 dB stronger.

23.1.3.10 RESERVED

23.1.3.11 MICROWAVE LANDING SYSTEM (MLS) CHARACTERISTICS

(a) **Definition**

- (1) **Auxiliary data.** Data, transmitted in addition to basic data that provide ground equipment siting information for use in refining airborne position calculations and other supplementary information.
- (2) **Basic data.** Data transmitted by the ground equipment that are associated directly with the operation of the landing guidance system.
- (3) **Beam centre.** The midpoint between the two minus 3-dB points on the leading and trailing edges of the scanning beam main lobe.
- (4) **Beamwidth.** The width of the scanning beam main lobe measured at the minus 3-dB points and defined in angular units on the boresight, in the horizontal plane for the azimuth function and in the vertical plane for the elevation function.
- (5) **Clearance guidance sector.** The subpart of airspace, inside the coverage sector, within which the azimuth guidance information provided is not proportional to the angular displacement of the aircraft, but is a constant left or right indication of which side the aircraft is with respect to the proportional guidance sector.
- (6) **Control motion noise.** (CMN). That portion of the guidance signal error which causes control surface, wheel and column motion and could affect aircraft attitude angle during coupled flight, but does not cause aircraft displacement from the desired course and/or glide path. (See 23.1.3.5.)
- (7) **Coordinate system — conical.** A function is said to use conical coordinates when the decoded guidance angle varies as the minimum angle between the surface of a cone containing the receiver antenna, and a plane perpendicular to the axis of the cone and passing through its apex. The apex of the cone is at the antenna phase centre. For approach azimuth or back azimuth functions, the plane is the vertical plane containing the runway centre line. For elevation functions, the plane is horizontal.
- (8) **Coordinate system — planar.** A function is said to use planar coordinates when the decoded guidance angle varies as the angle between the plane containing the receiver antenna and a reference plane. For azimuth functions, the reference plane is the vertical plane containing the runway centre line and the plane containing the receiver antenna is a vertical plane passing through the antenna phase centre.
- (9) **Coverage sector.** A subpart of airspace within which service is provided by a particular function and in which the signal power density is equal to or greater than the specified minimum.
- (10) **DME/P.** The distance measuring element of the MLS, where the "P" stands for precise distance measurement. The spectrum characteristics are those of DME/N.
- (11) **Function.** A particular service provided by the MLS, e.g. approach azimuth guidance, back azimuth guidance or basic data, etc.
- (12) **Mean course error.** The mean value of the azimuth error along the runway extended centre line.

- (13) **Mean glide path error.** The mean value of the -elevation error along the glide path of an elevation function.
- (14) **Minimum glide path.** The lowest angle of descent along the zero degree azimuth that is consistent with published approach procedures and obstacle clearance criteria.
- (15) **MLS antenna boresight.** The plane passing through the antenna phase centre perpendicular to the horizontal axis contained in the plane of the antenna array.
- (16) **MLS azimuth.** The locus of points in any horizontal plane where the decoded guidance angle is constant.
- (17) **MLS approach reference datum.** A point at a specified height above the intersection of the runway centre line and the threshold.
- (18) **MLS back azimuth reference datum.** A point at a specified height above the runway centre line at the runway midpoint.
- (19) **MLS datum point.** The point on the runway centre line closest to the phase centre of the approach elevation antenna.
- (20) **MLS elevation.** The locus of points in any vertical plane where the decoded guidance angle is constant.
- (21) **MLS zero degree azimuth.** The MLS azimuth where the decoded guidance angle is zero degrees.
- (22) **Out-of-coverage indication signal.** A signal radiated into areas outside the intended coverage sector where required to specifically prevent invalid removal of an airborne warning indication in the presence of misleading guidance information.
- (23) **Path following error (PFE).** That portion of the guidance signal error which could cause aircraft displacement from the desired course and/or glide path.
- (24) **Path following noise (PFN).** That portion of the guidance signal error which could cause aircraft displacement from the mean course line or mean glide path as appropriate.
- (25) **Proportional guidance sector.** The subpart of airspace within which the angular guidance information provided by a function is directly proportional to the angular displacement of the airborne antenna with respect to the zero angle reference.

(b) General

- (1) MLS is a precision approach and landing guidance system which provides position information and various ground to air data. The position information is provided in a wide coverage sector and is determined by an azimuth angle measurement, an elevation angle measurement and a range (distance) measurement.

Note. — Unless specifically indicated as the MLS airborne equipment, the text in 23.1.3.10 refers to the MLS ground equipment.

(c) MLS configurations

- (1) Basic MLS. The basic configuration of the MLS shall be composed of the following:
- i) approach azimuth equipment, associated monitor, remote control and indicator equipment;
 - ii) approach elevation equipment, associated monitor, remote control and indicator equipment;
 - iii) a means for the encoding and transmission of essential data words, associated monitor, remote control and indicator equipment;

Note. — The essential data are those basic and essential auxiliary data words specified in 23.1.3.10(e) (4).

- iv) DME/N, associated monitor, remote control and indicator equipment.
- (2) If precise ranging information throughout the azimuth coverage sector is required, the option of DME/P, conforming to the Provisions of 23.1.3.5 shall be applied.
- (3) Expanded MLS configurations. It shall be permissible to derive expanded configurations from the basic MLS, by addition of one or more of the following functions or characteristic improvements:
- i) back azimuth equipment, associated monitor, remote control and indicator equipment;
 - ii) flare elevation equipment, associated monitor, remote control and indicator equipment;
 - iii) DME/P, associated monitor, remote control and indicator equipment;
 - iv) a means for the encoding and transmission of additional auxiliary data words, associated monitor, remote control and indicator equipment;
 - v) a wider proportional guidance sector exceeding the minimum specified in 23.1.3.10 (e) below.
- (4) Simplified MLS configurations. It shall be permissible to derive simplified configurations from the basic MLS (23.1.3.10 (c) (1)), by relaxation of characteristics as follows:
- i) an approach azimuth coverage provided in approach region (23.1.3.10 (e) (2) (ii) (A) and (B)) only;
 - ii) an approach azimuth and elevation coverage (23.1.3.10 (e) (2) (ii) and 23.1.3.10 (e) (3) (ii)) not extending below a height of 30 m (100 ft) above the threshold;
 - iii) accuracy limits for PFE and PFN expanded to be not greater than 1.5 times the values specified in 23.1.3.10(d) (9) (iv) for approach azimuth guidance and in 23.1.3.10 (d) (9) (vi) for elevation guidance;
 - iv) ground equipment contribution to the mean course error and to the mean glide path error expanded to be 1.5 times the values specified in 23.1.3.10 (e) (2) (v) and 23.1.3.10 (e) (2) (v), respectively;

- v) CMN requirements (23.1.3.10(d) (9) (iv) and 23.1.3.10 (d) (9) (vi)) waived; and
- vi) monitor and control action period (23.1.3.10 (e) (2) (iii) and 23.1.3.10 (e) (3) (iii)) expanded to a six-second period.

(d) Signal-in-space characteristics — angle and data functions

(1) Channelling

- i) Channel arrangement. The MLS angle and data functions shall operate on any one of the 200 channels assigned on the frequencies from 5031.0 MHz to 5090.7 MHz as shown in Table A.
 - A. Channel assignments in addition to those specified in 23.1.3.10 (d) (1) (i) shall be made within the 5030.4 to 5150.0 MHz sub-band as necessary to satisfy future air navigation requirements.
- ii) Channel pairing with DME. The channel pairing of the angle and data channel with the channel of the ranging function shall be taken in accordance with Table A.
- iii) Frequency tolerance. The operating radio frequency of the ground equipment shall not vary more than plus or minus 10 kHz from the assigned frequency. The frequency stability shall be such that there is no more than a plus or minus 50 Hz deviation from the nominal frequency when measured over a one-second interval.
- iv) Radio frequency signal spectrum. The transmitted signal shall be such that, during the transmission time, the mean power density above a height of 600 m (2 000 ft) shall not exceed -94.5 dBW/m² for angle guidance or data signals, as measured in a 150 kHz bandwidth centred 840 kHz or more from the nominal frequency.
 - A. The transmitted signal shall be such that, during the transmission time, the mean power density above a height of 600m (2 000 ft) shall not exceed -94.5 dBW/m² for angle guidance or data signals, as measured in a 150 kHz bandwidth centred 840 kHz or more from the nominal frequency.
 - B. The transmitted signal shall be such that, during the transmission time, the mean power density beyond a distance of 4 800 m (2.6 NM) from any antennas and for a height below 600 m (2 000 ft) shall not exceed -94.5 dBW/m² for angle guidance or data signals, as measured in a 150 kHz bandwidth centred 840 kHz or more from the nominal frequency.

Note 1. — Requirements in 3.11.4.1.4.2 are applicable when the operational coverage of another MLS ground station has overlap with the radio-horizon of the considered ground station.

- (2) Polarization. The radio frequency transmissions from all ground equipment shall be nominally vertically polarized. The effect of any horizontally polarized component shall not cause the guidance information to change by more than 40 per cent of the PFE allowed at that location with the airborne antenna rotated 30 degrees from the vertical position or cause the PFE limit to be exceeded.

- (3) Time-division-multiplex (TDM) organization
- i) Both angle information and data shall be transmitted by TDM on a single radio frequency channel.
 - ii) Synchronization. The transmissions from the various angle and data ground equipments serving a particular runway shall be time synchronized to assure interference-free operations on the common radio frequency channel of operation.
 - iii) Function rates. Each function transmitted shall be repeated at the rates shown in the following table:

<i>Function</i>	<i>Average rate (Hz) measured over any 10-second period</i>
Approach azimuth guidance	13 ± 0.5
High rate approach azimuth guidance	39 ± 1.5
Back azimuth guidance	6.5 ± 0.25
Approach elevation guidance	39 ± 1.5
Flare elevation guidance	39 ± 1.5
Basic data	see Appendix A, Table A-7
Auxiliary data	see Appendix A, Tables A-10 and A-12

- A. When the proportional guidance sector is not greater than plus or minus 40 degrees and a need for flare elevation or other growth functions at that facility is not anticipated, the high rate approach azimuth function shall be used.
 - iv) Function timing. Timing standards for each angle and data function shall be as specified in IS: 23.1.3.10.4, Tables A-1 through A-6 and A-8. The ground equipment internal timing accuracy of each listed event including jitter shall be the specified nominal value plus or minus 2 microseconds. The timing jitter shall be less than 1 microsecond root mean square (RMS).
 - v) Function sequence. The time interval between repetitive transmissions of any one function shall be varied in a manner which provides protection from synchronous interference.
- (4) Preamble
- i) A preamble signal shall be transmitted throughout the applicable coverage sector to identify the particular function to follow. The preamble shall consist of a radio frequency carrier acquisition period, a receiver reference time code, and a function identification code. The

- timing of the preamble transmissions shall be as specified in IS: 23.1.3.10.4, Table A-1.
- ii) Carrier acquisition. The preamble transmission shall begin with a period of unmodulated radio frequency carrier as specified in IS: 23.1.3.10.4, Table A-1.
 - iii) Modulation and coding
 - A. Differential phase shift keying (DPSK). The preamble codes and the basic and auxiliary data signals specified in 23.1.3.10.4.8 below shall be transmitted by DPSK of the radio frequency carrier. A "zero" shall be represented by a 0 degrees plus or minus 10 degrees phase shift and a "one" shall be represented by a 180 degrees plus or minus 10 degrees phase shift. The modulation rate shall be 15 625 bauds. The internal timing accuracy of the DPSK transition shall be as specified in 23.1.3.10 (d) (3) (iv) above. There shall be no amplitude modulation applied during the phase transition. The transition time shall not exceed 10 microseconds, and the phase shall advance or retard monotonically throughout the transition region.
 - B. Receiver reference time. All preambles shall contain the receiver reference time code, 11101 (bits I1 to I5). The time of the last phase transition midpoint in the code shall be the receiver reference time. The receiver reference time code shall be validated by decoding a valid function identification immediately following the receiver reference time code.
 - C. Function identification. A code for function identification shall follow the receiver reference time code. This code shall consist of the five information bits (I6 to I10) allowing identification of 31 different functions, plus two parity bits (I11 and I12) as shown in the following table:

<i>Function</i>	<i>Code</i>						
	<i>I₆</i>	<i>I₇</i>	<i>I₈</i>	<i>I₉</i>	<i>I₁₀</i>	<i>I₁₁</i>	<i>I₁₂</i>
Approach azimuth	0	0	1	1	0	0	1
High rate approach azimuth	0	0	1	0	1	0	0
Approach elevation	1	1	0	0	0	0	1
Flare elevation	0	1	1	0	0	0	1
Back azimuth	1	0	0	1	0	0	1
360° azimuth	0	1	0	0	1	0	1
Basic data 1	0	1	0	1	0	0	0
Basic data 2	0			1	1	0	0
Basic data 3	1			0	0	0	0
Basic data 4	1			0	1	0	0
Basic data 5	1			1	1	0	0
Basic data 6	0			1	1	0	1
Auxiliary data A	1			0	0	1	0
Auxiliary data B	1			0	1	1	1
Auxiliary data C	1			1	0	0	0

Note.— The function identification codes have been chosen so that parity bits I_{11} and I_{12} satisfy the equations:

$$I_6 + I_7 + I_8 + I_9 + I_{10} + I_{11} = \text{EVEN}$$

$$I_6 + I_8 + I_{10} + I_{12} = \text{EVEN}$$

- (5) Angle guidance parameters. Angle guidance information shall be encoded by the amount of time separation between the centres of the received TO and FRO scanning beam main lobes. The coding shall be interpreted in the airborne equipment as a linear function of time as follows:

$$\theta = (T_0 - t)V/2$$

where:

θ = Azimuth or elevation guidance angle in degrees

t = Time separation in microseconds between TO and FRO beam centres

T_0 = Time separation in microseconds between TO and FRO beam centres corresponding to zero degrees

V = Scan velocity scaling constant in degrees per microsecond.

- i) The values of the angle guidance parameters shall be as shown in the following table:

<i>Function</i>	<i>Maximum scan angle (degrees)</i>	<i>Value of t for maximum scan angle (μs)</i>	<i>T_0 (μs)</i>	<i>V (degrees/μs)</i>
Approach azimuth	-62 to +62	13 000	6 800	0.020
High rate approach azimuth	-42 to +42	9 000	4 800	0.020
Back azimuth	-42 to +42	9 000	4 800	-0.020
Approach elevation	-1.5 to +29.5	3 500	3 350	0.020
Flare elevation	-2 to +10	3 200	2 800	0.010

- ii) The tolerances on the ground equipment scanning beam velocity and the time separation between TO and FRO pulses corresponding to zero degrees shall be sufficient to satisfy the accuracy requirements specified in 23.1.3.10 (d) (9) below.

- iii) The TO and FRO scan transmissions shall be symmetrically disposed about the mid-scan point listed in each of Tables A-2 through A-5 of IS: 23.1.3.10.4. The mid-scan point and the centre of the time interval between the TO and FRO scan transmissions shall coincide with a tolerance of plus or minus 10 microseconds.

(6) Azimuth guidance functions

- i) Each transmission of a guidance angle shall consist of a clockwise TO scan followed by a counterclockwise FRO scan as viewed from above the antenna. For approach azimuth functions, increasing angle values shall be in the direction of the TO scan. For the back azimuth functions, increasing angle values shall be in the direction of the FRO scan.
- ii) Sector signals. The transmission format of any azimuth function shall include time slots for airborne antenna selection, out-of-coverage indication, and test pulses as specified in IS: 23.1.3.10.4, Tables A-2 and A-3. The internal timing accuracy of the sector signals shall conform to the internal timing accuracy of the DPSK transitions specified in 23.1.3.10.4.3.4 above.
 - A. Ground equipment identification. The MLS providing services for a particular runway shall be identified by a four-character alphabetic designator starting with the letter M. This designator less the first letter shall be transmitted as a digital word as listed in IS: 23.1.3.10.4, Table A-7.
 - B. The signal shall be transmitted on the data channel into the approach and back azimuth coverage regions.
 - C. The code bit in the time slot previously allocated for the alternate (Morse code) ground equipment identification following the azimuth preamble shall be fixed in the "ZERO" state.
- iii) Airborne antenna selection signal. A signal for airborne antenna selection shall be transmitted as a "zero" DPSK signal lasting for a six-bit period. The signal shall be available throughout the coverage sector in which approach or back azimuth guidance is provided.
- iv) Azimuth out-of-coverage indication pulses. Where out-of-coverage indication pulses are used, they shall be:
 - A. greater than any guidance signal in the out-of-coverage sector;
 - B. at least 5 dB less than the fly-left (fly-right) clearance level within the fly-left (fly-right) clearance sector; and
 - C. at least 5 dB less than the scanning beam level within the proportional coverage region.

The duration of each pulse measured at the half amplitude point shall be at least 100 microseconds, and the rise and fall times shall be less than 10 microseconds.

- v) If desired, it shall be permissible to sequentially transmit two pulses in each out-of-coverage indication time slot. Where the pulse pairs are used, the duration of each pulse shall be at least 50 microseconds and the rise and fall times shall be less than 10 microseconds.

- vi) The transmissions of out-of-coverage indication pulses radiated from antennas with overlapping coverage patterns shall be separated by at least 10 microseconds.
 - vii) Ground radiated test signals
 - viii) Clearance guidance. Where the proportional guidance sector provided is less than the minimum coverage specified in 23.1.3.10 (e) (2) (ii) (A), (B) and (C) below, clearance guidance shall be provided to supplement the coverage sector by the transmission of fly-left/fly-right clearance pulses in the formats for the approach azimuth, high rate approach azimuth and back azimuth functions. Alternatively, it shall be permissible to provide clearance guidance by permitting the scanning beam to scan beyond the designated proportional guidance sector to provide fly-left or fly-right clearance information as appropriate when the decoded angle exceeds the designated limits of proportional guidance coverage.
 - A. Clearance guidance information shall be provided by transmitting pairs of pulses within the angle scan time slots. One pair shall consist of one pulse adjacent to the start time of the scanning beam TO scan and one pulse adjacent to the stop time of the FRO scan. A second pair shall consist of one pulse adjacent to the stop time of the scanning beam TO scan, and one pulse adjacent to the start time of the FRO scan. The fly-right clearance pulses shall represent positive angles and the fly-left clearance pulses shall represent negative angles. The duration of each clearance pulse shall be 50 microseconds with a tolerance of plus or minus 5 microseconds. The transmitter switching time between the clearance pulses and the scanning beam transmissions shall not exceed 10 microseconds. The rise time at the edge of each clearance pulse not adjacent to the scanning beam shall be less than 10 microseconds.
 - B. The signal-in-space characteristics of the clearance guidance pulses shall be as follows:
 - C. within the fly-right clearance guidance sector, the fly-right clearance guidance signal shall exceed the scanning beam side lobes and all other guidance and out-of-coverage indication signals by at least 5 dB;
 - D. within the fly-left clearance guidance sector, the fly-left clearance guidance signal shall exceed the scanning beam side lobes and all other guidance and out-of-coverage indication signals by at least 5 dB;
 - E. within the proportional guidance sector, the clearance guidance signals shall be at least 5 dB below the scanning beam main lobe.
 - ix) The power density of the clearance signal shall be as required below.
 - A. clearance and scanning beam timing arrangements;
 - B. pulse envelopes in the transition regions between clearance and scanning beam signals;
 - C. clearance (fly-right/fly-left) convention changes.
- (7) Elevation guidance functions
- i) Scanning conventions. For the approach elevation function, increasing elevation guidance angles shall be in the upward direction. Zero elevation angle shall coincide with a horizontal plane through the respective antenna phase centre. Each guidance angle transmission shall consist of a TO scan

- followed by a FRO scan. The TO scan shall be Ln the direction of increasing angle values.
- ii) Sector signal. Provision for transmission of one out-of-coverage indication pulse shall be made in the format for the approach elevation function. Where an out-of-coverage indication pulse is used, it shall be: (1) greater than any guidance signal in the out-of-coverage indication sector and (2) at least 5 dB less than the guidance signals within the guidance sector. The elevation out-of-coverage indication timing shall be as shown in IS: 23.1.3.10.4, Table A-4. The duration of each pulse measured at the half amplitude points shall be at least 100 microseconds, and the rise and fall times shall be less than 10 microseconds.
 - A. If desired, it shall be permissible to sequentially transmit two pulses in each obstacle clearance indication time slot. Where pulse pairs are used, the duration of each pulse shall be at least 50 microseconds, and the rise and fall times shall be less than 10 microseconds.
- (8) Data functions. Provision shall be made in the MLS signal format for the transmission of basic data and auxiliary data.
- i) Data transmission. Data shall be transmitted as specified in 23.1.3.10 (d) (4) (iii) (A) above.
 - ii) Basic data structure and timing. Basic data shall be encoded as 32-bit words consisting of a function preamble (12 bits) specified in 23.1.3.10.4.4 above, and data content as specified in IS: 23.1.3.10.4, Table A-7. The timing of the basic data words shall be as specified in IS: 23.1.3.10.4, Table A-6. The content, maximum interval between transmission of the same word and organization of the words shall be as specified in IS: 23.1.3.10.4, Table A-7. Data containing digital information shall be transmitted with the least significant bit first. The smallest binary number shall represent the lower absolute range limit with increments in binary steps to the upper absolute range limit specified in IS: 23.1.3.10.4, Table A-7.
 - A. Basic data contents. The data items specified in Appendix A, Table A-7 shall be defined as follows:
 - B. Approach azimuth antenna to threshold distance shall represent the minimum distance between the approach azimuth antenna phase centers to the vertical plane perpendicular to the centre line which contains the runway threshold.
 - C. Approach azimuth proportional coverage limit shall represent the limit of the sector in which proportional approach azimuth guidance is transmitted.
 - D. Clearance signal type shall indicate the method of providing the azimuth clearance signal.
 - E. Minimum glide path shall represent the lowest angle of descent along the zero-degree azimuth as defined in 23.1.3.10 (a)
 - F. Back azimuth status shall represent the operational status of the back azimuth equipment.
 - G. DME status shall represent the operational status of the DME equipment.
 - H. Approach azimuth status shall represent the operational status of the approach azimuth equipment.
 - I. Approach elevation status shall represent the operational status of the approach elevation equipment.
 - J. Beamwidth shall represent, for a particular function, the antenna beamwidth as defined in 23.1.3.10 (a).

- K. DME distance shall represent the minimum distance between the DME antenna phase centre and the vertical plane perpendicular to the runway centre line which contains the MLS datum point.
 - L. Approach azimuth magnetic orientation shall represent the angle measured in the horizontal plane clockwise from Magnetic North to the zero-degree approach azimuth, originating from the approach azimuth antenna. The vertex of the measured angle shall be the approach azimuth antenna phase centre.
 - M. Back azimuth magnetic orientation shall represent the angle measured in the horizontal plane clockwise from Magnetic North to the zero-degree back azimuth, originating from the back azimuth antenna. The vertex of the measured angle shall be the back azimuth antenna phase centre.
 - N. Back azimuth proportional coverage limit shall represent the limit of the sector in which proportional back azimuth guidance is transmitted.
 - O. MLS ground equipment identification shall represent the last three characters of the system identification specified in 23.1.3.10 (d) (6) (ii) (A). The characters shall be encoded in accordance with International Alphabet No. 5 (IA-5) using bits b1 through b6.
- iii) Auxiliary data organization and timing. Auxiliary data shall be organized into 76-bit words consisting of the function preamble (12 bits) as specified in 23.1.3.10 (d) (4), the address (8 bits) as specified in IS: 23.1.3.10.4, Table A-9, and data content and parity (56 bits) as specified in Appendix A, Tables A-10, A-11, A-12, A-13 and A-15. Three function identification codes are reserved to indicate transmission of auxiliary data A, auxiliary data B and auxiliary data C. The timing of the auxiliary data function shall be as specified in IS: 23.1.3.10.4, Table A-8. Two auxiliary data word formats shall be provided, one for digital data and one for alphanumeric character data. Data containing digital information shall be transmitted with the least significant bit first. Alpha characters in data words B1 through B39 shall be encoded in accordance with International Alphabet No. 5 (IA-5) using bits b1 to b5 with b1 transmitted first. Alphanumeric data characters in other data words shall be encoded in accordance with IA-5 using seven information bits, plus one even parity bit added to each character. Alphanumeric data shall be transmitted in the order in which they are to be read. The serial transmission of a character shall be with the lower order bit transmitted first and the parity bit transmitted last.
- iv) Auxiliary data A content. The data items contained in auxiliary data words A1 through A4 as specified in Appendix A, Table A-10 shall be defined as follows:
- A. Approach azimuth antenna offset shall represent the minimum distance between the approach azimuth antenna phase centre and a vertical plane containing the runway centre line.
 - B. Approach azimuth antenna to MLS datum point distance shall represent the minimum distance between the approach azimuth antenna phase centre and the vertical plane perpendicular to the runway centre line which contains the MLS datum point.
 - C. Approach azimuth alignment with runway centre line shall represent the minimum angle between the zero-degree approach azimuth and the runway centre line.
 - D. Approach azimuth antenna co-ordinate system shall represent the co-ordinate system (planar or conical) of the angle data transmitted by the approach azimuth antenna.

- E. Approach azimuth antenna height shall represent the vertical location of the antenna phase centre with respect to the MLS datum point.
 - F. Approach elevation antenna offset shall represent the minimum distance between the elevation antenna phase centre and a vertical plane containing the runway centre line.
 - G. MLS datum point to threshold distance shall represent the distance measured along the runway centre line from the MLS datum point to the runway threshold.
 - H. Approach elevation antenna height shall represent the vertical location of the elevation antenna phase centre with respect to the MLS datum point.
 - I. MLS datum point elevation shall represent the datum point elevation relative to mean sea level (msl).
 - J. Runway threshold height shall represent the vertical location of the intersection of the runway threshold and centre line with respect to the MLS datum point.
 - K. DME offset shall represent the minimum distance between the DME antenna phase centre and a vertical plane containing the runway centre line.
 - L. DME to MLS datum point distance shall represent the minimum distance between the DME antenna phase centre and the vertical plane perpendicular to the runway centre line which contains the MLS datum point.
 - M. DME antenna height shall represent the vertical location of the antenna phase centre with respect to the MLS datum point.
 - N. Runway stop-end distance shall represent the distance along centre line between the runway stop-end and the MLS datum points.
 - O. Back azimuth antenna offset shall represent the minimum distance between the back azimuth antenna phase centre and a vertical plane containing the runway centre line.
 - P. Back azimuth to MLS datum point distance shall represent the minimum distance between the back azimuth antenna and the vertical plane perpendicular to the runway centre line which contains the MLS datum point.
 - Q. Back azimuth alignment with runway centre line shall represent the minimum angle between the zero-degree back azimuth and the runway centre line.
 - R. Back azimuth antenna coordinate system shall represent the coordinate system (planar or conical) of the angle data transmitted by the back azimuth antenna.
 - S. Back azimuth antenna height shall represent the vertical location of the antenna phase centre with respect to the MLS datum point.
- v) Auxiliary data B content. Auxiliary data B words shall be defined as specified in IS: 23.1.3.10.4, Tables A-11 and A-13.
- A. Microwave landing system/area navigation (MLS/RNAV) procedure data. Where required, auxiliary data words B1 through B39 shall be used to transmit data to support MLS/RNAV procedures. It shall be permissible to divide this procedure data into two separate data bases: one for transmission in the approach azimuth sector, the other for transmission in the back azimuth sector. Data for each procedure shall be transmitted in the data base for the coverage sector in which the procedure commences. Missed approach procedure data shall be included in the data base containing the associated approach procedure.

- vi) Procedure data base structure. Where used, each procedure data base shall be constructed as follows:
- A. a map/CRC word shall identify the size of the data base, the number of procedures defined, and the cyclic redundancy check (CRC) code for validation of the database;
 - B. procedure descriptor words shall identify all named approach and departure procedures within the data base; and
 - C. way-point data words shall define the location and sequence of way-points for the procedures.

The structure and coding of auxiliary B words b) through B39 are defined in IS: 23.1.3.10.4, Tables A-14 through A-17.

- (9) System accuracy. The accuracy standards specified herein shall be met on a 95 per cent probability basis unless otherwise stated.
- i) MLS approach reference datum. The height of the MLS approach reference datum shall be 15 m (50 ft). A tolerance of plus 3 m (10 ft) shall be permitted.
 - ii) MLS back azimuth reference datum. The height of the MLS back azimuth reference datum shall be 15 m (50 ft). A tolerance of plus 3 m (10 ft) shall be permitted.
 - iii) The PFE shall be comprised of those frequency components of the guidance signal error at the output of the airborne receiver which lie below 0.5 rad/s for azimuth guidance information or below 1.5 rad/s for elevation guidance information. The control motion noise shall be comprised of those frequency components of the guidance signal error at the output of the airborne receiver which lie above 0.3 rad/s for azimuth guidance or above 0.5 rad/s for elevation guidance information. The output filter corner frequency of the receiver used for this measurement is 10 rad/s.
 - iv) Approach azimuth guidance functions. At the approach reference datum, the approach azimuth function shall provide performance as follows:
 - A. the PFE shall not be greater than plus or minus 6 m (20 ft);
 - B. the PFN shall not be greater than plus or minus 3.5 m (11.5 ft);
 - C. the CMN shall not be greater than plus or minus 3.2 m (10.5 ft) or 0.1 degree, whichever is less.
 - v) At the approach reference datum, the PFE shall not be greater than plus or minus 4 m (13.5 ft).
 - vi) The linear accuracy specified at the reference datum shall be maintained throughout the runway coverage region specified in 23.1.3.10.5.2.2.1.2 below except where degradation is allowed as specified in 23.1.3.10.4.9.4.3 below.
 - vii) Degradation allowance. The approach azimuth angular PFE, PFN and CMN shall be allowed to degrade linearly to the limits of coverage as follows:
 - A. With distance. The PFE limit and PFN limit, expressed in angular terms at 37 km (20 NM) from the runway threshold along the extended runway centre line, shall be 2 times the value specified at the approach reference datum. The CMN limit shall be 0.1 degree at 37 km (20 NM) from the approach reference datum along the extended runway centre line at the minimum glide path angle.
 - B. With azimuth angle. The PFE limit and PFN limit, expressed in angular terms at plus or minus 40 degrees azimuth angle, shall be 1.5 times the value on the extended runway centre line at the same distance from the approach reference datum. The CMN limit, expressed in angular terms at plus or minus 40 degrees azimuth

- angle is 1.3 times the value on the extended runway centre line at the same distance from the approach reference datum.
- C. With elevation angle. The PFE limit and PFN limit shall not degrade up to an elevation angle of 9 degrees. The PFE limit and PFN limit, expressed in angular terms at an elevation angle of 15 degrees from the approach azimuth antenna phase centre, shall be 2 times the value permitted below 9 degrees at the same distance from the approach reference datum and the same azimuth angle. The CMN limit shall not degrade with elevation angle.
 - D. Maximum CMN. The CMN limits shall not exceed 0.2 degree in any region of coverage.
 - E. The CMN shall not exceed 0.1 degree in any region of coverage.
- viii) Maximum angular PFE and PFN. In any region within coverage, the angular error limits shall be as follows:
- A. the PFE shall not exceed plus or minus 0.25 degree; and
 - B. the PFN shall not exceed plus or minus 0.15 degree.
- ix) Back azimuth guidance function. At the back azimuth reference datum, the back azimuth function shall provide performance as follows:
- A. the PFE shall not be greater than plus or minus 6 m (20ft);
 - B. the PFN component shall not be greater than plus or minus 3.5 m (11.5 ft);
 - C. the CMN shall not be greater than plus or minus 3.2 m (10.5 ft) or 0.1 degree, whichever is less.
- x) Degradation allowance. The back azimuth angular PFE, PFN and CMN shall be allowed to degrade linearly to the limits of coverage as follows:
- A. With distance. The PFE limit and PFN limit, expressed in angular terms at the limit of coverage along the extended runway centre line, shall be 2 times the value specified at the back azimuth reference datum. The CMN limit, expressed in angular terms at 18.5 km (10 NM) from the runway stop end along the extended runway centre line, shall be 1.3 times the value specified at the back azimuth reference datum.
 - B. With azimuth angle. The PFE limit and PFN limit, expressed in angular terms at plus or minus 20 degrees azimuth angle, shall be 1.5 times the value on the extended runway centre line at the same distance from the back azimuth reference datum. The CMN limit, expressed in angular terms at plus or minus 20 degrees azimuth angle, shall be 1.3 times the value on the extended runway centre line at the same distance from the back azimuth reference datum.
 - C. With elevation angle. The PFE limit and PFN limit shall not degrade up to an elevation angle of 9 degrees. The PFE limit and PFN limit, expressed in angular terms at an elevation angle of 15 degrees from the back azimuth antenna phase centre, shall be 2 times the value permitted below 9 degrees at the same distance from the back azimuth reference datum and the same azimuth angle. The CMN limit shall not degrade with elevation angle.
 - D. Maximum CMN. The CMN limits shall not exceed 0.2 degree in any region of coverage.
- xi) Maximum angular PFE and PFN. In any region within coverage, the angular error limits shall be as follows:
- A. the PFE shall not exceed plus or minus 0.50 degree; and
 - B. the PFN shall not exceed plus or minus 0.30 degree.
- xii) Elevation guidance function. For equipment sited to provide a minimum glide path of nominally 3 degrees or lower, the approach elevation function shall provide performance at the approach reference datum as follows:

- A. the PFE shall not be greater than plus or minus 0.6 m (2 ft);
 - B. the PFN shall not be greater than plus or minus 0.4 m (1-3 ft);
 - C. the CMN shall not be greater than plus or minus 0.3 m (1 ft).
- xiii) Degradation allowance. The approach elevation angular PFE, PFN and CMN shall be allowed to degrade linearly to the limits of coverage as follows:
- A. With distance. The PFE limit and PFN limit, expressed in angular terms at 37 km (20 NM) from the runway threshold on the minimum glide path, shall be 0.2 degree. The CMN limit shall be 0.1 degree at 37 km (20 NM) from the approach reference datum angle.
 - B. With azimuth angle. The PFE limit and PFN limit, expressed in angular terms at plus or minus 40 degrees azimuth angle, shall be 1.3 times the value on the extended runway centre line at the same distance from the approach reference datum. The CMN limit, expressed in angular terms at plus or minus 40 degrees azimuth angle, shall be 1.3 times the value on the extended runway centre line at the same distance from the approach reference datum.
 - C. With elevation angle. For elevation angles above the minimum glide path or 3 degrees, whichever is less and up to the maximum of the proportional guidance coverage and at the locus of points directly above the approach reference datum the PFE limit, PFN Limit and the CMN limit expressed in angular terms shall be allowed to degrade linearly such that at an elevation angle of 15 degrees the limits are 2 times the value specified at the reference datum. In no case shall the CMN directly above the reference datum exceed plus or minus 0.07 degree. For other regions of coverage within the angular sector from an elevation angle equivalent to the minimum glide path up to the maximum angle of proportional coverage the degradations with distance and azimuth angle specified in A and B shall apply.
 - D. The PFE, PFN and CMN limits shall not degrade with elevation angle in the region between the minimum glide path and 60 per cent of the minimum glide path. For elevation angles below 60 per cent of the minimum glide path and down to the limit of coverage specified in **23.1.3.10 (e) (3) (ii) (A) and (B)** below, and at the locus of points directly below the approach reference datum the PFE limit, the PFN limit and the CMN limit expressed in angular terms, shall be allowed to increase linearly to 6 times the value at the approach reference datum. For other regions of coverage within the angular sector from an elevation angle equivalent to 60 per cent of the minimum glide path angle value, and down to the limit of coverage the degradation with distance and azimuth angle specified in a) and b) shall apply. In no case shall the PFE be allowed to exceed 0.8 degree, or the CMN be allowed to exceed 0.4 degree.
 - E. Maximum CMN. For elevation angles above 60 per cent of the minimum glide path, the CMN limits shall not exceed 0.2 degree in any region of coverage.
- xiv) Maximum angular PFE and PFN. In any region within coverage, the angular error limits for elevation angles above 60 per cent of the minimum glide path shall be as follows:
- A. the PFE shall not exceed plus or minus 0.25 degree; and
 - B. the PFN shall not exceed plus or minus 0.15 degree.
- xv) The limit expressed in angular terms on the linear degradation of the PFE limit, the PFN limit and the CMN limit at angles below 60 per cent of the minimum glide path and down to the limit of coverage shall be 3 times the value permitted at the approach reference datum glide path, the CMN limits shall not exceed 0.1 degree in any region of coverage.

Note.— For other regions of coverage within the angular sector from an elevation angle equivalent to 60 per cent of the minimum glide path and down to the limit of coverage, the degradation with distance and azimuth angle specified in 23.1.3.10.4.9.6.1 a) and b) applies.

- xvi) The PFE shall not exceed 0.35 degree, and the CMN shall not exceed 0.2 degree.
- xvii) Approach elevation equipment sited to provide a minimum glide path higher than 3 degrees shall provide angular accuracies not less than those specified for equipment sited for a 3-degree minimum glide path within the coverage subpart.

(10) Power density

- i) The power density for DPSK, clearance and angle guidance signals shall be at least the values shown in the following table under all operational weather conditions at any point within coverage except as specified in 23.1.3.10.4.10.2 below.

Function	DPSK signals (dBW/m ²)	Angle signals (dBW/m ²) (antenna beamwidth)			Clearance signals (dBW/m ²)
		1°	2°	3°	
Approach azimuth guidance	-89.5	-85.7	-79.7	-76.2	-88.0
High rate approach azimuth guidance	-89.5	-88.0	-84.5	-81.0	-88.0
Back azimuth guidance	-89.5	-88.0	-82.7	-79.2	-88.0
Approach elevation guidance	-89.5	-88.0	-84.5	N/A	N/A

N/A = not applicable

Note.— The table above specifies the minimum power densities for clearance signals and scanning beam signals. The relative values of the two signals are specified in 23.1.3.10 (d) (6) (ii) (E).

- ii) The power density of the approach azimuth angle guidance signals shall be greater than that specified in 23.1.3.10 (d) (10) (i) above by at least:
 - A. 15 dB at the approach reference datum;
 - B. 5 dB for one degree or 9 dB for 2 degree or larger beamwidth antennas at 2.5 m (8 ft) above the runway surface, at the MLS datum point, or at the farthest point of the runway centre line which is in line of sight of the azimuth antenna.
- iii) Multipath relative power densities
 - A. Within the MLS azimuth coverage at 60 m (200 ft) or more above threshold, the duration of a reflected scanning beam signal whose power density is higher than four decibels below the approach azimuth guidance, or high rate azimuth guidance scanning beam signal power density, shall be shorter than one second, as seen by an aircraft on a published approach.
 - B. Within the MLS azimuth proportional guidance sector, below 60 m (200 ft) above threshold, the power density of any reflected approach azimuth guidance or high rate approach azimuth guidance scanning beam signal shall be less than ten decibels above the power density

of the approach azimuth guidance or high rate approach azimuth guidance scanning beam signal. On the runway centre line, this reflected signal shall not degrade the azimuth scanning beam shape and generate at the output of a receiver an error beyond the tolerances as stated in 23.1.3.10 (d) (9).

- C. Within the MLS elevation coverage, the duration of a reflected approach elevation guidance scanning beam signal whose power density is higher than four decibels below the approach elevation guidance scanning beam signal power density shall be shorter than one second, as seen by an aircraft on a published approach.

(e) Ground equipment characteristics

- (1) Synchronization and monitoring. The synchronization of the time-division- multiplexed angle guidance and data transmissions which are listed in 23.1.3.10(d) (iii) (C) above shall be monitored.
- i) Residual radiation of MLS functions. The residual radiation of an MLS function at times when another function is radiating shall be at least 70 dB below the level provided when transmitting.
- (2) Azimuth guidance equipment
- i) Scanning beam characteristics. Azimuth ground equipment antennas shall produce a fan-shaped beam which is narrow in the horizontal plane, broad in the vertical plane and which is scanned horizontally between the limits of the proportional guidance sector.
- A. Co-ordinate system. Azimuth guidance information shall be radiated in either conical or planar co-ordinates.
- B. Antenna beamwidth. The antenna beamwidth shall not exceed 4 degrees.
- C. Scanning beam shape. The minus 10-dB points on the beam envelope shall be displaced from the beam centre by at least 0.76 beamwidth, but not more than 0.96 beamwidth.
- ii) Coverage
- A. Approach azimuth. The approach azimuth ground equipment shall provide guidance information in at least the following subparts of space:
- B. Approach region.
- C. Laterally, within a sector of 80 degrees (normally plus and minus 40 degrees about the antenna boresight) which originates at the approach azimuth antenna phase centre.
- D. Longitudinally, from the approach azimuth antenna to 41.7 km (22.5 NM).
- E. Vertically, between:
- F. a lower conical surface originating at the approach azimuth antenna phase centre and inclined upward to reach, at the longitudinal coverage limit, a height of 600 m (2000 ft) above the horizontal plane which contains the antenna phase centre; and
- G. an upper conical surface originating at the approach azimuth antenna phase centre inclined at 15 degrees above the horizontal to a height of 6 000 m (20 000 ft).

Note.— Where the proportional guidance sector provided is less than the minimum lateral coverage specified in 23.1.3.10 (e) (2) (ii) (B), clearance guidance signals specified in 23.1.3.10 (d) (6) (ii) (E) are required.

- H. Runway region.
- I. Horizontally within a sector 45 m (150 ft) each side of the runway centre line beginning at the stop end and extending parallel with the runway centre line in the direction of the approach to join the minimum operational coverage region as described in 23.1.3.10 (e) (2) (ii) below.
- J. Vertically between:
 - K. a horizontal surface which is 2.5 m (8 ft) above the farthest point of the runway centre line which is in line of sight of the azimuth antenna; and
 - L. a conical surface originating at the azimuth ground equipment antenna inclined at 20 degrees above the horizontal up to a height of 600 m (2 000 ft).

Note. — It is intended that guidance below the line of sight may be allowed as long as the signal quality can satisfy the accuracy requirements in 23.1.

- M. The lower level of the coverage in the runway region shall be 2.5 m (8ft) above the runway centre line.
- N. Where required to support automatic landing, roll-out or take-off, the lower level of coverage in the runway region shall not exceed 2.5 m (8 ft) above the runway centre line.
- iii) Minimum operational coverage region.
 - A. Laterally, within a sector of plus and minus 10 degrees about the runway centre line which originates at the MLS datum point.
 - B. Longitudinally, from the runway threshold in the direction of the approach to the longitudinal coverage limit specified in 23.1.3.10 (e) (2) (ii).
 - C. Vertically, between:
 - D. a lower plane which contains the line 2.5 m (8 ft) above the runway threshold and is inclined upward to reach the height of the surface specified in 23.1.3.10 (e) (2) (ii) at the longitudinal coverage limit; and
 - E. the upper surface specified in 23.1.3.10 (e) (2) (ii).
- iv) The approach azimuth ground equipment shall provide guidance vertically to 30 degrees above the horizontal.
- v) The minimum proportional guidance sector shall be as follows:

Approach azimuth antenna to threshold distance (AAT)	Minimum proportional coverage
AAT < 500 m (1 640 ft)	±8°
500 m (1 640 ft) < AAT < 3 100 m (10 170 ft)	±6°
3 100 m (10 170 ft) < AAT	±4°

- vi) Back azimuth. The back azimuth ground equipment shall provide information in at least the following subpart of space:
- A. Horizontally, within a sector plus or minus 20 degrees about the runway centre line originating at the back azimuth ground equipment antenna and extending in the direction of the missed approach at least 18.5 km (10 NM) from the runway stop end.
 - B. Vertically, in the runway region between:
 - C. a horizontal surface 2.5 m (8 ft) above the farthest point of runway centre line that is in line of sight of the back azimuth antenna; and
 - D. a conical surface originating at the back azimuth ground equipment antenna inclined at 20 degrees above the horizontal up to a height of 600 m (2 000 ft).
 - E. Vertically, in the back azimuth region between:
 - F. a conical surface originating 2.5 m (8 ft) above the runway stop end, inclined at 0.9 degree above the horizontal; and
 - G. a conical surface originating at the back azimuth ground equipment antenna, inclined at 15 degrees above the horizontal up to a height of 3000 m (10000ft).
 - H. The back azimuth facility shall provide guidance information to 30 degrees above the horizontal.
 - I. The minimum proportional guidance sector shall be plus or minus 10 degrees about the runway centre line.
- vii) Monitor and control
- A. The approach azimuth and back azimuth monitor systems shall cause the radiation of their respective functions to cease and a warning shall be provided at the designated control points if any of the following conditions persist for longer than the periods specified:
 - B. there is a change in the ground equipment contribution to the mean course error such that the PFE at the approach reference datum or in the direction of any azimuth radial exceeds the limits specified in 23.1.3.10 (d) (9) (iv) and 23.1.3.10 (d) (9) (v) and (for simplified MLS configuration) in 23.1.3.10 (c) (4) for a period of more than one second or (for simplified MLS configuration) for a period of more than six seconds;
 - C. there is a reduction in the radiated power to less than that necessary to satisfy the requirements specified in 23.1.3.10 (d) (10) (i) and 23.1.3.10 (d) (6) (ii) for a period of more than one second;
 - D. there is an error in the preamble DPSK transmissions which occurs more than once in any one-second period;
 - E. there is an error in the TDM synchronization of a particular azimuth function such that the requirement specified in 23.1.3.10 (d) (3) (ii) is not satisfied, and this condition persists for more than one second.
 - F. Design and operation of the monitor system shall cause radiation to cease and a warning shall be provided at the designated control points in the event of failure of the monitor system itself.
 - G. The period during which erroneous guidance information is radiated, including period(s) of zero radiation, shall not exceed the periods specified in 23.1.3.10 (e) (2) (iii) (A). Attempts to clear a fault by resetting the primary ground equipment or by switching to standby ground equipment shall be completed within this time. If the fault is not cleared within the time allowed, the radiation shall cease. After

shutdown, no attempt shall be made to restore service until a period of 20 seconds has elapsed.

- viii) Integrity and continuity of service requirements for MLS azimuth
 - A. The probability of not radiating false guidance signals shall not be less than $1 - 0.5 \times 10^{-9}$ in any one landing for an MLS azimuth intended to be used for Categories II and III operations.
 - B. The probability of not radiating false guidance signals shall not be less than $1 - 1.0 \times 10^{-7}$ in any one landing for an MLS azimuth intended to be used for Category I operations.
 - C. The probability of not losing the radiated guidance signal shall be greater than:
 - D. $1 - 2 \times 10^{-6}$ in any period of 15 seconds for an MLS azimuth intended to be used for Category n or Category IDA operations (equivalent to 2000 hours mean time between outages); and
 - E. $1 - 2 \times 10^{-6}$ in any period of 30 seconds for an MLS azimuth intended to be used for the full range of Category HI operations (equivalent to 4000 hours mean time between outages).
- ix) The probability of not losing the radiated guidance signal shall exceed $1 - 4 \times 10^{-6}$ in any period of 15 seconds for an MLS azimuth intended to be used for Category I operations (equivalent to 1000 hours mean time between outages).
- x) Ground equipment accuracy
 - A. The ground equipment contribution to the mean course error shall not exceed an error equivalent to plus or minus 3 m (10 ft) at the MLS approach reference datum.
 - B. The ground equipment contribution to the CMN at the reference datum shall not exceed 1m (3.3 ft) or 0.03 degree, whichever is less, on a 95 per cent probability basis.
- xi) Siting
 - A. Normally, the approach azimuth ground equipment antenna shall be located on the extension of the runway centre line beyond the stop end and shall be adjusted so that the vertical plane containing the zero degree course line will contain the MLS approach reference datum. Siting of the antenna shall be consistent with safe obstacle clearance provisions in Annex 14.
 - B. The back azimuth ground equipment antenna shall normally be located on the extension of the runway centre line at the threshold end, and the antenna shall be adjusted so that the vertical plane containing the zero degree course line will contain the back azimuth reference datum.

(3) Elevation guidance equipment

- i) Scanning beam characteristics. The elevation ground equipment antenna shall produce a fan-shaped beam that is narrow in the vertical plane, broad in the horizontal plane and which is scanned vertically between the limits of the proportional guidance sector.
 - A. Co-ordinate system. Approach elevation guidance information shall be radiated in conical coordinates.
 - B. Antenna beamwidth. The antenna beamwidth shall not exceed 2.5 degrees.
 - C. Scanning beam shape. The minus 10-dB points on the beam envelope shall be displayed from the centre line by at least 0.76 beamwidth but not more than 0.96 beamwidth.
- ii) Coverage

- A. Approach elevation. The approach elevation ground equipment shall provide proportional guidance information in at least the following subpart of space.
 - B. Approach region
 - C. Laterally, within a sector originating at the elevation antenna phase centre which has an angular extent at least equal to the proportional guidance sector provided by the approach azimuth ground equipment at the longitudinal coverage limit.
 - D. Longitudinally, from the elevation antenna in the direction of the approach to 37 km (20 NM) from threshold.
 - E. Vertically, between:
 - F. a lower conical surface originating at the elevation antenna phase centre and inclined upward to reach, at the longitudinal coverage limit, a height of 600 m (2000 ft) above the horizontal plane which contains the antenna phase centre; and
 - G. an upper conical surface originating at the elevation antenna phase centre and inclined 7.5 degrees above the horizontal up to a height of 6000 m (20000 ft).
 - H. The approach elevation ground equipment shall provide proportional guidance to angles greater than 7.5 degrees above the horizontal when necessary to meet operational requirements.
 - I. Minimum operational coverage region.
 - J. Laterally, within a sector originating at the MLS datum point, of plus and minus 10 degrees about the runway centre line;
 - K. Longitudinally, 75 m (250 ft) from the MLS datum point in the direction of threshold, to the far coverage limit specified in [23.1.3.10 \(e\) \(3\) \(ii\) \(B\)](#);
 - L. Vertically, between the upper surface specified in [23.1.3.10 \(e\) \(3\) \(ii\)](#), and the higher of:
 - M. a surface which is the locus of points 2.5 m (8 ft) above the runway; or
 - N. a plane originating at the MLS datum point and inclined upward to reach, at the longitudinal coverage limit, the height of the surface specified in [23.1.3.10 \(e\) \(3\) \(ii\)](#).
- iii) Monitor and control
- A. The approach elevation monitor system shall cause the radiation of its respective functions to cease and a warning shall be provided at the designated control point if any of the following conditions persist for longer than the periods specified:
 - B. there is a change in the ground equipment contribution to the mean glide path error component such that the PFE at the approach reference datum or on any glide path consistent with published approach procedures exceeds the limits specified in [23.1.3.10 \(c\) \(9\) \(vi\)](#) and (for simplified MLS configuration) in [23.1.3.10 \(c\) \(4\)](#) for a period of more than one second or (for simplified MLS configuration) for a period of more than six seconds;
 - C. there is a reduction in the radiated power to less than that necessary to satisfy the requirements specified in [23.1.3.10 \(d\) \(10\) \(A\)](#) for a period of more than one second;
 - D. there is an error in the preamble DPSK transmissions which occurs more than once in any one-second period;
 - E. there is an error in the TDM synchronization of a particular elevation function such that the requirement specified in

- 23.1.3.10 (d) (3) (ii) is not satisfied and this condition persists for more than one second.
- F. Design and operation of the monitor system shall cause radiation to cease and a warning shall be provided at the designated control points in the event of failure of the monitor system itself.
- G. The period during which erroneous guidance information is radiated, including period(s) of zero radiation, shall not exceed the periods specified in 23.1.3.10 (e) (3) (iii) (A). Attempts to clear a fault by resetting the primary ground equipment or by switching to standby ground equipment shall be completed within this time. If the fault is not cleared within the time allowed, radiation shall cease. After shutdown, no attempt shall be made to restore service until a period of 20 seconds has elapsed.
- iv) Integrity and continuity of service requirements for MLS approach elevation
- A. The probability of not radiating false guidance signals shall not be less than $1 - 0.5 \times 10^{-9}$ in any one landing for an MLS approach elevation intended to be used for Categories II and III operations.
- B. The probability of not radiating false guidance signals shall not be less than $1 - 1.0 \times 10^{-7}$ in any one landing on MLS approach elevation intended to be used for Category I operations.
- C. The probability of not losing the radiated guidance signal shall be greater than $1 - 2 \times 10^{-6}$ in any period of 15 seconds for an MLS approach elevation intended to be used for Categories II and III operations (equivalent to 2 000 hours mean time between outages).
- D. The probability of not losing the radiated guidance signal shall exceed $1 - 4 \times 10^{-6}$ in any period of 15 seconds for an MLS approach elevation intended to be used for Category I operations (equivalent to 1 000 hours mean time between outages).
- v) Ground equipment accuracy
- A. The ground equipment contribution to the mean glide path error component of the PFE shall not exceed an error equivalent to plus or minus 0.3 m (1 ft) at the approach reference datum.
- B. The ground equipment contribution to the CMN at the reference datum shall not exceed 0.15 m (0.5 ft) on a 95 per cent probability basis.
- vi) Siting
- A. The approach elevation ground equipment antenna shall be located beside the runway. Siting of the antennas shall be consistent with obstacle clearance Provisions in Annex 14.
- B. The approach elevation ground equipment antenna shall be sited so that the asymptote of the minimum glide path crosses the threshold at the MLS approach reference datum.
- C. The minimum glide path angle is normally 3 degrees and shall not exceed 3 degrees except where alternative means of satisfying obstacle clearance requirements are impractical.
- D. The approach elevation ground equipment antenna shall be sited so that the height of the point which corresponds to the decoded guidance signal of the minimum glide path above the threshold does not exceed 18m (60 ft).

E. When ILS and MLS simultaneously serve the same runway, the ILS reference datum and the MLS approach reference datum shall coincide within a tolerance of 1 m (3 ft).

(4) Data coverage and monitoring

i) Basic data

- A. The basic data words 1, 2, 3, 4 and 6 shall be transmitted throughout the approach azimuth coverage sector.
- B. Where the back azimuth function is provided, basic data words 4, 5 and 6 shall be transmitted throughout the approach azimuth and back azimuth coverage sectors.

ii) Auxiliary data

- A. Auxiliary data words A1, A2 and A3 shall be transmitted throughout the approach azimuth coverage sector.
- B. Where the back azimuth function is provided, auxiliary data words A3 and A4 shall be transmitted throughout the approach azimuth and back azimuth coverage sectors.
- C. When provided, auxiliary data B words shall be transmitted throughout the approach azimuth sector, except that the words comprising the back azimuth procedure data base shall be transmitted throughout the back azimuth sector.
- D. If the back azimuth function is provided, the appropriate auxiliary data B words shall be transmitted.

iii) Monitor and control

- A. The monitor system shall provide a warning to the designated control point if the radiated power is less than that necessary to satisfy the DPSK requirement specified in 23.1.3.10 (d) (10) (i) above.
- B. If a detected error in the basic data radiated into the approach azimuth coverage occurs in at least two consecutive samples, radiation of these data, approach azimuth and elevation functions shall cease.
- C. If a detected error in the basic data radiated into the back azimuth coverage occurs in at least two consecutive samples, radiation of these data and the back azimuth function shall cease.

(5) Distance measuring equipment

- i) DME information shall be provided at least throughout the coverage subpart in which approach and back azimuth guidance is available.
- ii) DME information shall be provided throughout 360° azimuth if operationally required.

(f) Airborne equipment characteristics

(1) Angle and data functions

i) Accuracy

- A. Where the DPSK and scanning beam signal power densities are the minimum specified in 23.1.3.10 (d) (10) (i) above, the airborne equipment shall be able to acquire the signal and any decoded angle signal shall have a CMN not exceeding 0.1 degree, except that the back azimuth guidance function CMN shall not exceed 0.2 degree.
- B. Where the radiated signal power density is high enough to cause the airborne receiver noise contribution to be insignificant, the airborne equipment shall not degrade the accuracy of any decoded angle

guidance signal by greater than plus or minus 0.017 degree (PFE), and plus or minus 0.015 degree (azimuth), and plus or minus 0.01 degree (elevation) CMN.

- C. In order to obtain accurate guidance to 2.5 m (8 ft) above the runway surface, the airborne equipment shall produce less than 0.04 degree CMN with the power densities indicated in 23.1.3.10 (d) (10) (ii) above.
 - ii) Dynamic range
 - A. The airborne equipment shall be able to acquire the signal and the performance in 23.1.3.10 (f) (1) (i) (B) above shall be met where the power density of any of the radiated signals has any value between the minimum specified in 23.1.3.10 (d) (10) (i) above up to a maximum of minus 14.5 dBW/m²
 - B. The receiver performance shall not degrade beyond the specified limits when the maximum differential levels permitted in 23.1.3.10 (f) (2) (i) above exist between signal power densities of individual functions.
 - iii) Receiver angle data output filter characteristics
 - A. For sinusoidal input frequencies, receiver output filters shall not induce amplitude variations or phase lags in the angle data which exceed those obtained with a single pole low-pass filter with a corner frequency of 10 rad/s by more than 20 per cent.
 - iv) Adjacent channel spurious response. The receiver performance specified in 23.1.3.10 (f) above shall be met when the ratio between the desired tracked signals and the noise produced by the adjacent channel signals in a 150 kHz bandwidth centred around the desired frequency is equal to or greater than the signal-to-noise ratio (SNR) values:
 - A. as specified in Table X1 when the power density received from the desired ground station is equal to or higher than the values as specified in Table Y, or
 - B. as specified in the Table X2 when the power density received from the desired ground station is between the minimum density power values specified in 23.1.3.10 (d) (10) (i) and the values specified in Table Y.

Table Y

<i>Function</i>	<i>Beam width (Note 2)</i>		
	<i>1°</i>	<i>2°</i>	<i>3°</i>
Approach azimuth guidance	-69.8 dBW/m ²	-63.8 dBW/m ²	-60.2 dBW/m ²
High rate approach azimuth guidance	-74.6 dBW/m ²	-69.5 dBW/m ²	-65 dBW/m ²
Approach elevation guidance	-71 dBW/m ²	-65 dBW/m ²	N/A
Back azimuth	N/A (Note 4)	N/A (Note 4)	N/A (Note 4)

Table X1

SNR (Note 1)
Beam width (Note 2)

<i>Function</i>	<i>Data</i>	<i>1°</i>	<i>2°</i>	<i>3°</i>
Approach azimuth guidance	5 dB	24.7 dB	30.7 dB	34.3 dB
High rate approach azimuth guidance	5 dB	19.9 dB	26 dB	29.5 dB
Approach elevation guidance	5 dB	23.5 dB	29.5 dB	N/A
Back azimuth (Note 4)	5 dB	5.2 dB	11.2 dB	14.8 dB

Table X2

<i>Function</i>	<i>Data</i>	<i>SNR (Note 1)</i>		
		<i>Beam width (Note 2)</i>		
		<i>1°</i>	<i>2°</i>	<i>3°</i>
Approach azimuth guidance	5 dB	8.2 dB	14.3 dB	17.8 dB
High rate approach azimuth guidance	5 dB	3.5 dB	9.5 dB	13 dB
Approach elevation guidance	5 dB	3.5 dB	9.5 dB	N/A
Back azimuth (Note 4)	5 dB	5.2 dB	11.2 dB	14.8 dB

Note 1.— When the radiated desired signal power density is high enough to cause the airborne receiver noise contribution to be insignificant, the airborne CMN contribution for elevation and approach azimuth guidance (not for back azimuth) is required as stated in 23.1.3.10 (f) (1) (i), to be reduced compared to the CMN contribution when the radiated desired signal power density is at the minimum specified in 23.1.3.10 (d) (10) (i) and the minimum SNR values are therefore higher.

Note 2.— The relationship is linear between adjacent points designated by the beam widths.

Note 3.— These SNR values are to be protected through application of frequency separation criteria as explained in Attachment G, 9.3.

Note 4.— As there is no change in back azimuth guidance accuracy when the airborne receiver noise may be considered as insignificant, the same SNR values are applied for back azimuth.

Table A. DME / MLS angle, DME/VOR and DME/ILS/MLS channelling and pairing.

Channel pairing				DME parameters									
				Interrogation				Reply					
				DME channel number	VHF frequency MHz	MLS angle frequency MHz	MLS channel number	Frequency MHz	DME/N μ s	Pulse codes		Frequency MHz	Pulse codes μ s
										DME/P mode			
						Initial approach μ s	Final approach μ s						
*1X	–	–	–	1 025	12	–	–	962	12				
**1Y	–	–	–	1 025	36	–	–	1 088	30				
*2X	–	–	–	1 026	12	–	–	963	12				
**2Y	–	–	–	1 026	36	–	–	1 089	30				
*3X	–	–	–	1 027	12	–	–	964	12				
**3Y	–	–	–	1 027	36	–	–	1 090	30				
*4X	–	–	–	1 028	12	–	–	965	12				
**4Y	–	–	–	1 028	36	–	–	1 091	30				
*5X	–	–	–	1 029	12	–	–	966	12				
**5Y	–	–	–	1 029	36	–	–	1 092	30				
*6X	–	–	–	1 030	12	–	–	967	12				
**6Y	–	–	–	1 030	36	–	–	1 093	30				
*7X	–	–	–	1 031	12	–	–	968	12				
**7Y	–	–	–	1 031	36	–	–	1 094	30				
*8X	–	–	–	1 032	12	–	–	969	12				
**8Y	–	–	–	1 032	36	–	–	1 095	30				
*9X	–	–	–	1 033	12	–	–	970	12				
**9Y	–	–	–	1 033	36	–	–	1 096	30				
*10X	–	–	–	1 034	12	–	–	971	12				
**10Y	–	–	–	1 034	36	–	–	1 097	30				
*11X	–	–	–	1 035	12	–	–	972	12				
**11Y	–	–	–	1 035	36	–	–	1 098	30				
*12X	–	–	–	1 036	12	–	–	973	12				
**12Y	–	–	–	1 036	36	–	–	1 099	30				
*13X	–	–	–	1 037	12	–	–	974	12				
**13Y	–	–	–	1 037	36	–	–	1 100	30				
*14X	–	–	–	1 038	12	–	–	975	12				
**14Y	–	–	–	1 038	36	–	–	1 101	30				
*15X	–	–	–	1 039	12	–	–	976	12				
**15Y	–	–	–	1 039	36	–	–	1 102	30				
*16X	–	–	–	1 040	12	–	–	977	12				
**16Y	–	–	–	1 040	36	–	–	1 103	30				

Channel pairing				DME parameters									
				Interrogation				Reply					
				DME channel number	VHF frequency MHz	MLS angle frequency MHz	MLS channel number	Frequency MHz	DME/N µs	Pulse codes		Frequency MHz	Pulse codes µs
										Initial approach µs	Final approach µs		
DME/P mode													
V17X	108.00	-	-	1 041	12	-	-	978	12				
17Y	108.05	5 043.0	540	1 041	36	36	42	1 104	30				
17Z	-	5 043.3	541	1 041	-	21	27	1 104	15				
18X	108.10	5 031.0	500	1 042	12	12	18	979	12				
18W	-	5 031.3	501	1 042	-	24	30	979	24				
18Y	108.15	5 043.6	542	1 042	36	36	42	1 105	30				
18Z	-	5 043.9	543	1 042	-	21	27	1 105	15				
19X	108.20	-	-	1 043	12	-	-	980	12				
19Y	108.25	5 044.2	544	1 043	36	36	42	1 106	30				
19Z	-	5 044.5	545	1 043	-	21	27	1 106	15				
20X	108.30	5 031.6	502	1 044	12	12	18	981	12				
20W	-	5 031.9	503	1 044	-	24	30	981	24				
20Y	108.35	5 044.8	546	1 044	36	36	42	1 107	30				
20Z	-	5 045.1	547	1 044	-	21	27	1 107	15				
21X	108.40	-	-	1 045	12	-	-	982	12				
21Y	108.45	5 045.4	548	1 045	36	36	42	1 108	30				
21Z	-	5 045.7	549	1 045	-	21	27	1 108	15				
22X	108.50	5 032.2	504	1 046	12	12	18	983	12				
22W	-	5 032.5	505	1 046	-	24	30	983	24				
22Y	108.55	5 046.0	550	1 046	36	36	42	1 109	30				
22Z	-	5 046.3	551	1 046	-	21	27	1 109	15				
23X	108.60	-	-	1 047	12	-	-	984	12				
23Y	108.65	5 046.6	552	1 047	36	36	42	1 110	30				
23Z	-	5 046.9	553	1 047	-	21	27	1 110	15				
24X	108.70	5 032.8	506	1 048	12	12	18	985	12				
24W	-	5 033.1	507	1 048	-	24	30	985	24				
24Y	108.75	5 047.2	554	1 048	36	36	42	1 111	30				
24Z	-	5 047.5	555	1 048	-	21	27	1 111	15				
25X	108.80	-	-	1 049	12	-	-	986	12				
25Y	108.85	5 047.8	556	1 049	36	36	42	1 112	30				
25Z	-	5 048.1	557	1 049	-	21	27	1 112	15				
26X	108.90	5 033.4	508	1 050	12	12	18	987	12				
26W	-	5 033.7	509	1 050	-	24	30	987	24				
26Y	108.95	5 048.4	558	1 050	36	36	42	1 113	30				
26Z	-	5 048.7	559	1 050	-	21	27	1 113	15				

Channel pairing				DME parameters									
				Interrogation				Reply					
				DME channel number	VHF frequency MHz	MLS angle frequency MHz	MLS channel number	Frequency MHz	DME/N μ s	Pulse codes		Frequency MHz	Pulse codes μ s
										DME/P mode			
						Initial approach μ s	Final approach μ s						
28X	109.10	5 034.0	510	1 052	12	12	18	989	12				
28W	-	5 034.3	511	1 052	-	24	30	989	24				
28Y	109.15	5 049.6	562	1 052	36	36	42	1 115	30				
28Z	-	5 049.9	563	1 052	-	21	27	1 115	15				
29X	109.20	-	-	1 053	12	-	-	990	12				
29Y	109.25	5 050.2	564	1 053	36	36	42	1 116	30				
29Z	-	5 050.5	565	1 053	-	21	27	1 116	15				
30X	109.30	5 034.6	512	1 054	12	12	18	991	12				
30W	-	5 034.9	513	1 054	-	24	30	991	24				
30Y	109.35	5 050.8	566	1 054	36	36	42	1 117	30				
30Z	-	5 051.1	567	1 054	-	21	27	1 117	15				
31X	109.40	-	-	1 055	12	-	-	992	12				
31Y	109.45	5 051.4	568	1 055	36	36	42	1 118	30				
31Z	-	5 051.7	569	1 055	-	21	27	1 118	15				
32X	109.50	5 035.2	514	1 056	12	12	18	993	12				
32W	-	5 035.5	515	1 056	-	24	30	993	24				
32Y	109.55	5 052.0	570	1 056	36	36	42	1 119	30				
32Z	-	5 052.3	571	1 056	-	21	27	1 119	15				
33X	109.60	-	-	1 057	12	-	-	994	12				
33Y	109.65	5 052.6	572	1 057	36	36	42	1 120	30				
33Z	-	5 052.9	573	1 057	-	21	27	1 120	15				
34X	109.70	5 035.8	516	1 058	12	12	18	995	12				
34W	-	5 036.1	517	1 058	-	24	30	995	24				
34Y	109.75	5 053.2	574	1 058	36	36	42	1 121	30				
34Z	-	5 053.5	575	1 058	-	21	27	1 121	15				
35X	109.80	-	-	1 059	12	-	-	996	12				
35Y	109.85	5 053.8	576	1 059	36	36	42	1 122	30				
35Z	-	5 054.1	577	1 059	-	21	27	1 122	15				
36X	109.90	5 036.4	518	1 060	12	12	18	997	12				
36W	-	5 036.7	519	1 060	-	24	30	997	24				
36Y	109.95	5 054.4	578	1 060	36	36	42	1 123	30				
36Z	-	5 054.7	579	1 060	-	21	27	1 123	15				

Channel pairing				DME parameters									
				Interrogation				Reply					
				DME channel number	VHF frequency MHz	MLS angle frequency MHz	MLS channel number	Frequency MHz	DME/N μ s	Pulse codes		Frequency MHz	Pulse codes μ s
										DME/P mode			
						Initial approach μ s	Final approach μ s						
39X	110.20	–	–	1 063	12	–	–	1 000	12				
39Y	110.25	5 056.2	584	1 063	36	36	42	1 126	30				
39Z	–	5 056.5	585	1 063	–	21	27	1 126	15				
40X	110.30	5 037.6	522	1 064	12	12	18	1 001	12				
40W	–	5 037.9	523	1 064	–	24	30	1 001	24				
40Y	110.35	5 056.8	586	1 064	36	36	42	1 127	30				
40Z	–	5 057.1	587	1 064	–	21	27	1 127	15				
41X	110.40	–	–	1 065	12	–	–	1 002	12				
41Y	110.45	5 057.4	588	1 065	36	36	42	1 128	30				
41Z	–	5 057.7	589	1 065	–	21	27	1 128	15				
42X	110.50	5 038.2	524	1 066	12	12	18	1 003	12				
42W	–	5 038.5	525	1 066	–	24	30	1 003	24				
42Y	110.55	5 058.0	590	1 066	36	36	42	1 129	30				
42Z	–	5 058.3	591	1 066	–	21	27	1 129	15				
43X	110.60	–	–	1 067	12	–	–	1 004	12				
43Y	110.65	5 058.6	592	1 067	36	36	42	1 130	30				
43Z	–	5 058.9	593	1 067	–	21	27	1 130	15				
44X	110.70	5 038.8	526	1 068	12	12	18	1 005	12				
44W	–	5 039.1	527	1 068	–	24	30	1 005	24				
44Y	110.75	5 059.2	594	1 068	36	36	42	1 131	30				
44Z	–	5 059.5	595	1 068	–	21	27	1 131	15				
45X	110.80	–	–	1 069	12	–	–	1 006	12				
45Y	110.85	5 059.8	596	1 069	36	36	42	1 132	30				
45Z	–	5 060.1	597	1 069	–	21	27	1 132	15				
46X	110.90	5 039.4	528	1 070	12	12	18	1 007	12				
46W	–	5 039.7	529	1 070	–	24	30	1 007	24				
46Y	110.95	5 060.4	598	1 070	36	36	42	1 133	30				
46Z	–	5 060.7	599	1 070	–	21	27	1 133	15				
47X	111.00	–	–	1 071	12	–	–	1 008	12				
47Y	111.05	5 061.0	600	1 071	36	36	42	1 134	30				
47Z	–	5 061.3	601	1 071	–	21	27	1 134	15				
48X	111.10	5 040.0	530	1 072	12	12	18	1 009	12				
48W	–	5 040.3	531	1 072	–	24	30	1 009	24				
48Y	111.15	5 061.6	602	1 072	36	36	42	1 135	30				
48Z	–	5 061.9	603	1 072	–	21	27	1 135	15				

Channel pairing				DME parameters					
				Interrogation				Reply	
				Frequency MHz	Pulse codes		Frequency MHz	Pulse codes	
					DME/N	DME/P mode			
DME channel number	VHF frequency MHz	MLS angle frequency MHz	MLS channel number	Initial approach µs	Final approach µs	Frequency MHz	Pulse codes		
30X	111.30	5 040.8	532	1 074	12	18	1 011	12	
30W	-	5 040.9	533	1 074	-	24	30	24	
30Y	111.35	5 062.8	606	1 074	36	36	42	30	
30Z	-	5 063.1	607	1 074	-	21	27	15	
31X	111.40	-	-	1 075	12	-	-	1 012	12
31Y	111.45	5 063.4	608	1 075	36	36	42	30	
31Z	-	5 063.7	609	1 075	-	21	27	15	
32X	111.50	5 041.2	534	1 076	12	18	1 013	12	
32W	-	5 041.5	535	1 076	-	24	30	24	
32Y	111.55	5 064.0	610	1 076	36	36	42	30	
32Z	-	5 064.3	611	1 076	-	21	27	15	
33X	111.60	-	-	1 077	12	-	-	1 014	12
33Y	111.65	5 064.6	612	1 077	36	36	42	30	
33Z	-	5 064.9	613	1 077	-	21	27	15	
34X	111.70	5 041.8	536	1 078	12	18	1 015	12	
34W	-	5 042.1	537	1 078	-	24	30	24	
34Y	111.75	5 065.2	614	1 078	36	36	42	30	
34Z	-	5 065.5	615	1 078	-	21	27	15	
35X	111.80	-	-	1 079	12	-	-	1 016	12
35Y	111.85	5 065.8	616	1 079	36	36	42	30	
35Z	-	5 066.1	617	1 079	-	21	27	15	
36X	111.90	5 042.4	538	1 080	12	18	1 017	12	
36W	-	5 042.7	539	1 080	-	24	30	24	
36Y	111.95	5 066.4	618	1 080	36	36	42	30	
36Z	-	5 066.7	619	1 080	-	21	27	15	
37X	112.00	-	-	1 081	12	-	-	1 018	12
37Y	112.05	-	-	1 081	36	-	-	1 144	30
38X	112.10	-	-	1 082	12	-	-	1 019	12
38Y	112.15	-	-	1 082	36	-	-	1 145	30
39X	112.20	-	-	1 083	12	-	-	1 020	12
39Y	112.25	-	-	1 083	36	-	-	1 146	30
**30X	-	-	-	1 084	12	-	-	1 021	12
**30Y	-	-	-	1 084	36	-	-	1 147	30
**31X	-	-	-	1 085	12	-	-	1 022	12
**31Y	-	-	-	1 085	36	-	-	1 148	30
**32X	-	-	-	1 086	12	-	-	1 023	12
**32Y	-	-	-	1 086	36	-	-	1 149	30

Channel pairing				DME parameters					
				Interrogation				Reply	
				Pulse codes		DME/P mode		Frequency MHz	Pulse codes µs
				Initial approach µs	Final approach µs				
DME channel number	VHF frequency MHz	MLS angle frequency MHz	MLS channel number	Frequency MHz	DME/N µs	Initial approach µs	Final approach µs	Frequency MHz	Pulse codes µs
**64X	-	-	-	1 088	12	-	-	1 151	12
**64Y	-	-	-	1 088	36	-	-	1 025	30
**65X	-	-	-	1 089	12	-	-	1 152	12
**65Y	-	-	-	1 089	36	-	-	1 026	30
**66X	-	-	-	1 090	12	-	-	1 153	12
**66Y	-	-	-	1 090	36	-	-	1 027	30
**67X	-	-	-	1 091	12	-	-	1 154	12
**67Y	-	-	-	1 091	36	-	-	1 028	30
**68X	-	-	-	1 092	12	-	-	1 155	12
**68Y	-	-	-	1 092	36	-	-	1 029	30
**69X	-	-	-	1 093	12	-	-	1 156	12
**69Y	-	-	-	1 093	36	-	-	1 030	30
70X	112.30	-	-	1 094	12	-	-	1 157	12
**70Y	112.35	-	-	1 094	36	-	-	1 031	30
71X	112.40	-	-	1 095	12	-	-	1 158	12
**71Y	112.45	-	-	1 095	36	-	-	1 032	30
72X	112.50	-	-	1 096	12	-	-	1 159	12
**72Y	112.55	-	-	1 096	36	-	-	1 033	30
73X	112.60	-	-	1 097	12	-	-	1 160	12
**73Y	112.65	-	-	1 097	36	-	-	1 034	30
74X	112.70	-	-	1 098	12	-	-	1 161	12
**74Y	112.75	-	-	1 098	36	-	-	1 035	30
75X	112.80	-	-	1 099	12	-	-	1 162	12
**75Y	112.85	-	-	1 099	36	-	-	1 036	30
76X	112.90	-	-	1 100	12	-	-	1 163	12
**76Y	112.95	-	-	1 100	36	-	-	1 037	30
77X	113.00	-	-	1 101	12	-	-	1 164	12
**77Y	113.05	-	-	1 101	36	-	-	1 038	30
78X	113.10	-	-	1 102	12	-	-	1 165	12
**78Y	113.15	-	-	1 102	36	-	-	1 039	30
79X	113.20	-	-	1 103	12	-	-	1 166	12
**79Y	113.25	-	-	1 103	36	-	-	1 040	30
80X	113.30	-	-	1 104	12	-	-	1 167	12
80Y	113.35	5 067.0	620	1 104	36	36	42	1 041	30
80Z	-	5 067.3	621	1 104	-	21	27	1 041	15

Channel pairing				DME parameters									
				Interrogation				Reply					
				DME channel number	VHF frequency MHz	MLS angle frequency MHz	MLS channel number	Frequency MHz	DME/N µs	Pulse codes		Frequency MHz	Pulse codes µs
										Initial approach µs	Final approach µs		
		DME/P mode											
81X	113.40	-	-	1 105	12	-	-	1 168	12				
81Y	113.45	5 067.6	622	1 105	36	36	42	1 042	30				
81Z	-	5 067.9	623	1 105	-	21	27	1 042	15				
82X	113.50	-	-	1 106	12	-	-	1 169	12				
82Y	113.55	5 068.2	624	1 106	36	36	42	1 043	30				
82Z	-	5 068.5	625	1 106	-	21	27	1 043	15				
83X	113.60	-	-	1 107	12	-	-	1 170	12				
83Y	113.65	5 068.8	626	1 107	36	36	42	1 044	30				
83Z	-	5 069.1	627	1 107	-	21	27	1 044	15				
84X	113.70	-	-	1 108	12	-	-	1 171	12				
84Y	113.75	5 069.4	628	1 108	36	36	42	1 045	30				
84Z	-	5 069.7	629	1 108	-	21	27	1 045	15				
85X	113.80	-	-	1 109	12	-	-	1 172	12				
85Y	113.85	5 070.0	630	1 109	36	36	42	1 046	30				
85Z	-	5 070.3	631	1 109	-	21	27	1 046	15				
86X	113.90	-	-	1 110	12	-	-	1 173	12				
86Y	113.95	5 070.6	632	1 110	36	36	42	1 047	30				
86Z	-	5 070.9	633	1 110	-	21	27	1 047	15				
87X	114.00	-	-	1 111	12	-	-	1 174	12				
87Y	114.05	5 071.2	634	1 111	36	36	42	1 048	30				
87Z	-	5 071.5	635	1 111	-	21	27	1 048	15				
88X	114.10	-	-	1 112	12	-	-	1 175	12				
88Y	114.15	5 071.8	636	1 112	36	36	42	1 049	30				
88Z	-	5 072.1	637	1 112	-	21	27	1 049	15				
89X	114.20	-	-	1 113	12	-	-	1 176	12				
89Y	114.25	5 072.4	638	1 113	36	36	42	1 050	30				
89Z	-	5 072.7	639	1 113	-	21	27	1 050	15				
90X	114.30	-	-	1 114	12	-	-	1 177	12				
90Y	114.35	5 073.0	640	1 114	36	36	42	1 051	30				
90Z	-	5 073.3	641	1 114	-	21	27	1 051	15				
91X	114.40	-	-	1 115	12	-	-	1 178	12				
91Y	114.45	5 073.6	642	1 115	36	36	42	1 052	30				
91Z	-	5 073.9	643	1 115	-	21	27	1 052	15				
92X	114.50	-	-	1 116	12	-	-	1 179	12				
92Y	114.55	5 074.2	644	1 116	36	36	42	1 053	30				
92Z	-	5 074.5	645	1 116	-	21	27	1 053	15				
93X	114.60	-	-	1 117	12	-	-	1 180	12				
93Y	114.65	5 074.8	646	1 117	36	36	42	1 054	30				
93Z	-	5 075.1	647	1 117	-	21	27	1 054	15				

Channel pairing				DME parameters									
				Interrogation				Reply					
				DME channel number	VHF frequency MHz	MLS angle frequency MHz	MLS channel number	Frequency MHz	DME/N μ s	Pulse codes		Frequency MHz	Pulse codes μ s
										DME/P mode			
						Initial approach μ s	Final approach μ s						
94X	114.70	-	-	1 118	12	-	-	1 181	12				
94Y	114.75	5 075.4	648	1 118	36	36	42	1 055	30				
94Z	-	5 075.7	649	1 118	-	21	27	1 055	15				
95X	114.80	-	-	1 119	12	-	-	1 182	12				
95Y	114.85	5 076.0	650	1 119	36	36	42	1 056	30				
95Z	-	5 076.3	651	1 119	-	21	27	1 056	15				
96X	114.90	-	-	1 120	12	-	-	1 183	12				
96Y	114.95	5 076.6	652	1 120	36	36	42	1 057	30				
96Z	-	5 076.9	653	1 120	-	21	27	1 057	15				
97X	115.00	-	-	1 121	12	-	-	1 184	12				
97Y	115.05	5 077.2	654	1 121	36	36	42	1 058	30				
97Z	-	5 077.5	655	1 121	-	21	27	1 058	15				
98X	115.10	-	-	1 122	12	-	-	1 185	12				
98Y	115.15	5 077.8	656	1 122	36	36	42	1 059	30				
98Z	-	5 078.1	657	1 122	-	21	27	1 059	15				
99X	115.20	-	-	1 123	12	-	-	1 186	12				
99Y	115.25	5 078.4	658	1 123	36	36	42	1 060	30				
99Z	-	5 078.7	659	1 123	-	21	27	1 060	15				
100X	115.30	-	-	1 124	12	-	-	1 187	12				
100Y	115.35	5 079.0	660	1 124	36	36	42	1 061	30				
100Z	-	5 079.3	661	1 124	-	21	27	1 061	15				
101X	115.40	-	-	1 125	12	-	-	1 188	12				
101Y	115.45	5 079.6	662	1 125	36	36	42	1 062	30				
101Z	-	5 079.9	663	1 125	-	21	27	1 062	15				
102X	115.50	-	-	1 126	12	-	-	1 189	12				
102Y	115.55	5 080.2	664	1 126	36	36	42	1 063	30				
102Z	-	5 080.5	665	1 126	-	21	27	1 063	15				
103X	115.60	-	-	1 127	12	-	-	1 190	12				
103Y	115.65	5 080.8	666	1 127	36	36	42	1 064	30				
103Z	-	5 081.1	667	1 127	-	21	27	1 064	15				
104X	115.70	-	-	1 128	12	-	-	1 191	12				
104Y	115.75	5 081.4	668	1 128	36	36	42	1 065	30				
104Z	-	5 081.7	669	1 128	-	21	27	1 065	15				
105X	115.80	-	-	1 129	12	-	-	1 192	12				
105Y	115.85	5 082.0	670	1 129	36	36	42	1 066	30				
105Z	-	5 082.3	671	1 129	-	21	27	1 066	15				
106X	115.90	-	-	1 130	12	-	-	1 193	12				
106Y	115.95	5 082.6	672	1 130	36	36	42	1 067	30				
106Z	-	5 082.9	673	1 130	-	21	27	1 067	15				

Channel pairing				DME parameters									
				Frequency MHz				Interrogation		Reply			
								DME/N µs		Pulse codes		Frequency MHz	Pulse codes µs
										DME/P mode			
DME channel number	VHF frequency MHz	MLS angle frequency MHz	MLS channel number	Initial approach µs	Final approach µs	Frequency MHz	Pulse codes µs						
94X	114.70	-	-	1 118	12	-	-	1 181	12				
94Y	114.75	5 075.4	648	1 118	36	36	42	1 055	30				
94Z	-	5 075.7	649	1 118	-	21	27	1 055	15				
95X	114.80	-	-	1 119	12	-	-	1 182	12				
95Y	114.85	5 076.0	650	1 119	36	36	42	1 056	30				
95Z	-	5 076.3	651	1 119	-	21	27	1 056	15				
96X	114.90	-	-	1 120	12	-	-	1 183	12				
96Y	114.95	5 076.6	652	1 120	36	36	42	1 057	30				
96Z	-	5 076.9	653	1 120	-	21	27	1 057	15				
97X	115.00	-	-	1 121	12	-	-	1 184	12				
97Y	115.05	5 077.2	654	1 121	36	36	42	1 058	30				
97Z	-	5 077.5	655	1 121	-	21	27	1 058	15				
98X	115.10	-	-	1 122	12	-	-	1 185	12				
98Y	115.15	5 077.8	656	1 122	36	36	42	1 059	30				
98Z	-	5 078.1	657	1 122	-	21	27	1 059	15				
99X	115.20	-	-	1 123	12	-	-	1 186	12				
99Y	115.25	5 078.4	658	1 123	36	36	42	1 060	30				
99Z	-	5 078.7	659	1 123	-	21	27	1 060	15				
100X	115.30	-	-	1 124	12	-	-	1 187	12				
100Y	115.35	5 079.0	660	1 124	36	36	42	1 061	30				
100Z	-	5 079.3	661	1 124	-	21	27	1 061	15				
101X	115.40	-	-	1 125	12	-	-	1 188	12				
101Y	115.45	5 079.6	662	1 125	36	36	42	1 062	30				
101Z	-	5 079.9	663	1 125	-	21	27	1 062	15				
102X	115.50	-	-	1 126	12	-	-	1 189	12				
102Y	115.55	5 080.2	664	1 126	36	36	42	1 063	30				
102Z	-	5 080.5	665	1 126	-	21	27	1 063	15				
103X	115.60	-	-	1 127	12	-	-	1 190	12				
103Y	115.65	5 080.8	666	1 127	36	36	42	1 064	30				
103Z	-	5 081.1	667	1 127	-	21	27	1 064	15				
104X	115.70	-	-	1 128	12	-	-	1 191	12				
104Y	115.75	5 081.4	668	1 128	36	36	42	1 065	30				
104Z	-	5 081.7	669	1 128	-	21	27	1 065	15				
105X	115.80	-	-	1 129	12	-	-	1 192	12				
105Y	115.85	5 082.0	670	1 129	36	36	42	1 066	30				
105Z	-	5 082.3	671	1 129	-	21	27	1 066	15				
106X	115.90	-	-	1 130	12	-	-	1 193	12				
106Y	115.95	5 082.6	672	1 130	36	36	42	1 067	30				
106Z	-	5 082.9	673	1 130	-	21	27	1 067	15				

Channel pairing				DME parameters					
				Interrogation				Reply	
				Frequency MHz	DME/N µs	Pulse codes		Frequency MHz	Pulse codes µs
						DME/P mode			
DME channel number	VHF frequency MHz	MLS angle frequency MHz	MLS channel number	Initial approach µs	Final approach µs				
107X	116.00	-	-	1 131	12	-	-	1 194	12
107Y	116.05	5 083.2	674	1 131	36	36	42	1 068	30
107Z	-	5 083.5	675	1 131	-	21	27	1 068	15
108X	116.10	-	-	1 132	12	-	-	1 195	12
108Y	116.15	5 083.8	676	1 132	36	36	42	1 069	30
108Z	-	5 084.1	677	1 132	-	21	27	1 069	15
109X	116.20	-	-	1 133	12	-	-	1 196	12
109Y	116.25	5 084.4	678	1 133	36	36	42	1 070	30
109Z	-	5 084.7	679	1 133	-	21	27	1 070	15
110X	116.30	-	-	1 134	12	-	-	1 197	12
110Y	116.35	5 085.0	680	1 134	36	36	42	1 071	30
110Z	-	5 085.3	681	1 134	-	21	27	1 071	15
111X	116.40	-	-	1 135	12	-	-	1 198	12
111Y	116.45	5 085.6	682	1 135	36	36	42	1 072	30
111Z	-	5 085.9	683	1 135	-	21	27	1 072	15
112X	116.50	-	-	1 136	12	-	-	1 199	12
112Y	116.55	5 086.2	684	1 136	36	36	42	1 073	30
112Z	-	5 086.5	685	1 136	-	21	27	1 073	15
113X	116.60	-	-	1 137	12	-	-	1 200	12
113Y	116.65	5 086.8	686	1 137	36	36	42	1 074	30
113Z	-	5 087.1	687	1 137	-	21	27	1 074	15
114X	116.70	-	-	1 138	12	-	-	1 201	12
114Y	116.75	5 087.4	688	1 138	36	36	42	1 075	30
114Z	-	5 087.7	689	1 138	-	21	27	1 075	15
115X	116.80	-	-	1 139	12	-	-	1 202	12
115Y	116.85	5 088.0	690	1 139	36	36	42	1 076	30
115Z	-	5 088.3	691	1 139	-	21	27	1 076	15
116X	116.90	-	-	1 140	12	-	-	1 203	12
116Y	116.95	5 088.6	692	1 140	36	36	42	1 077	30
116Z	-	5 088.9	693	1 140	-	21	27	1 077	15
117X	117.00	-	-	1 141	12	-	-	1 204	12
117Y	117.05	5 089.2	694	1 141	36	36	42	1 078	30
117Z	-	5 089.5	695	1 141	-	21	27	1 078	15
118X	117.10	-	-	1 142	12	-	-	1 205	12
118Y	117.15	5 089.8	696	1 142	36	36	42	1 079	30
118Z	-	5 090.1	697	1 142	-	21	27	1 079	15
119X	117.20	-	-	1 143	12	-	-	1 206	12
119Y	117.25	5 090.4	698	1 143	36	36	42	1 080	30
119Z	-	5 090.7	699	1 143	-	21	27	1 080	15

Channel pairing				DME parameters									
				Interrogation				Reply					
				DME channel number	VHF frequency MHz	MLS angle frequency MHz	MLS channel number	Frequency MHz	DME/N μ s	Pulse codes		Frequency MHz	Pulse codes μ s
										DME/P mode			
						Initial approach μ s	Final approach μ s						
120X	117.30	-	-	1 144	12	-	-	1 207	12				
120Y	117.35	-	-	1 144	36	-	-	1 081	30				
121X	117.40	-	-	1 145	12	-	-	1 208	12				
121Y	117.45	-	-	1 145	36	-	-	1 082	30				
122X	117.50	-	-	1 146	12	-	-	1 209	12				
122Y	117.55	-	-	1 146	36	-	-	1 083	30				
123X	117.60	-	-	1 147	12	-	-	1 210	12				
123Y	117.65	-	-	1 147	36	-	-	1 084	30				
124X	117.70	-	-	1 148	12	-	-	1 211	12				
**124Y	117.75	-	-	1 148	36	-	-	1 085	30				
125X	117.80	-	-	1 149	12	-	-	1 212	12				
**125Y	117.85	-	-	1 149	36	-	-	1 086	30				
126X	117.90	-	-	1 150	12	-	-	1 213	12				
**126Y	117.95	-	-	1 150	36	-	-	1 087	30				

* These channels are reserved exclusively for national allotments.

** These channels may be used for national allotment on a secondary basis.
The primary reason for reserving these channels is to provide protection for the secondary surveillance radar (SSR) system.

∇ 108.0 MHz is not scheduled for assignment to ILS service. The associated DME operating channel No. 17X may be assigned for emergency use. The reply frequency of channel No. 17X (i.e. 978 MHz) is also utilized for the operation of the universal access transceiver (UAT). Standards and Recommended Practices for UAT are found in Annex 10, Volume III, Part I, Chapter 12.

Table B. Allowable DME/P errors

Location	Standard	Mode	PFE	CMN
37 km (20 NM) to 9.3 km (5NM) from MLS approach reference datum	1 and 2	IA	±250 m (±820 ft) reducing linearly to ±85 m (±279 ft)	±68 m (±223 ft) reducing linearly to ±34 m (±111 ft)
9.3 km (5 NM) to MLS approach reference datum	1	FA	±85 m (±279 ft) reducing linearly to ±30 m (±100 ft)	±18 m (±60 ft)
	2	FA	±85 m (±279 ft) reducing linearly to ±12 m (±40 ft)	±12 m (±40 ft)
	see Note	IA	±100 m (±328 ft)	±68 m (±223 ft)
At MLS approach reference datum and through runway coverage	1	FA	±30 m (±100 ft)	±18 m (±60 ft)
	2	FA	±12 m (±40 ft)	±12 m (±40 ft)
Throughout back azimuth coverage volume	1 and 2	FA	±100 m (±328 ft)	±68 m (±223 ft)
	see Note	IA	±100 m (±328 ft)	±68 m (±223 ft)

Note.— At distances from 9.3 km (5 NM) to the MLS approach reference datum and throughout the back azimuth coverage, the IA mode may be used when the FA mode is not operative.

PART 23.1- IMPLEMENTING STANDARDS

For ease of reference, the number assigned to each implementing standard corresponds to its associated regulation. For example, IS: 23.1.2.1 would reflect a standard required in subsection 23.1.2.1

IS: 23.1.3.7. TECHNICAL SPECIFICATIONS FOR THE GLOBAL NAVIGATION SATELLITE SYSTEM (GNSS)

1. DEFINITIONS

GBAS/E. A ground-based augmentation system transmitting an elliptically-polarized VHF data broadcast.

GBAS/H. A ground-based augmentation system transmitting a horizontally-polarized VHF data broadcast.

Receiver. A subsystem that receives GNSS signals and includes one or more sensors.

Reserved (bits/words/fields). Bits/words/fields that are not allocated, but which are reserved for a particular GNSS application.

Spare (bits/words/fields). Bits/words/fields that are not allocated or reserved, and which are available for future allocation.

Note. — All spare bits are set to zero.

2. GENERAL

Note. — The following technical specifications supplement the provisions of Chapter 3, 3.7.

3. GNSS ELEMENTS

3.1 Global Positioning System (GPS) Standard Positioning Service (SPS) (L1)

3.1.1 NON-AIRCRAFT ELEMENTS

3.1.1.1 RADIO FREQUENCY (RF) CHARACTERISTICS

3.1.1.1.1 Carrier phase noise. The carrier phase noise spectral density of the unmodulated carrier shall be such that a phase locked loop of 10 Hz one-sided noise bandwidth is able to track the carrier to an accuracy of 0.1 radian (1 sigma).

3.1.1.1.2 Spurious emissions. In-band spurious emissions shall be at least 40 dB below the unmodulated L1 carrier over the allocated channel bandwidth.

3.1.1.1.3 Correlation loss. The loss in the recovered signal power due to imperfections in the signal modulation and waveform distortion shall not exceed 1 dB.

Note.— The loss in signal power is the difference between the broadcast power in a 2.046 MHz bandwidth and the signal power recovered by a noise-free, loss-free receiver with 1-chip correlator spacing and a 2.046 MHz bandwidth.

3.1.1.1.4 Coarse/acquisition (C/A) code generation and timing. Each C/A code pattern $G_i(t)$ shall be formed by the Modulo-2 sum of two 1 023-bit linear patterns, G_1 and G_{2i} . The G_{2i} sequence shall be formed by effectively delaying the G_2 sequence by an integer number of chips to produce one of 36 unique $G_i(t)$ patterns defined in Table B-1. The G_1 and G_2 sequences shall be generated by 10-stage shift registers having the following polynomials as referred to in the shift register input:

- a) $G_1: X^{10} + X^3 + 1$; and
- b) $G_2: X^{10} + X^9 + X^8 + X^6 + X^3 + X^2 + 1$.

The initialization vector for the G_1 and G_2 sequences shall be “1111111111”. The code phase assignments shall be as shown in Table B-1. The G_1 and G_2 registers shall be clocked at a 1.023 MHz rate. Timing relationships related to the C/A code shall be as shown in Figure B-1.*

3.1.1.2 Data structure. The navigation message shall be formatted as shown in Figure B-2. Each page, as shown in Figure B-6, shall utilize a basic format of a 1 500-bit-long frame with up to 5 subframes, each of 300 bits in length. All words shall be transmitted most significant bit (MSB) first.

3.1.1.2.1 Subframe structure. Each subframe and/or page of a subframe shall start with a telemetry (TLM) word followed by a handover word (HOW). The HOW shall be followed by 8 data words. Each word in each frame shall contain 6 parity bits. The TLM word and HOW formats shall be as shown in Figures B-3 and B-4, respectively.

3.1.1.2.2 End/start of week. At the end/start of week:

- a) the cyclic paging of subframes 1 through 5 shall restart with subframe 1 regardless of which subframe was last transmitted prior to the end/start of week; and
- b) the cycling of 25 pages of subframes 4 and 5 shall restart with page 1 of each of the subframes, regardless of which page was transmitted prior to the end/start of week. All upload and page cutovers shall occur on frame boundaries (i.e. Modulo 30 seconds relative to the end/start of week).

Note.— New data in subframes 4 and 5 may start to be transmitted with any of the 25 pages of these subframes.

3.1.1.2.3 Data parity. Words 1 through 10 of subframes 1 through 5 shall each contain 6 parity bits as their least significant bits (LSBs). In addition, two non-information bearing bits shall be provided as bits 23 and 24 of words 2 and 10 for parity computation purposes.

3.1.1.2.4 Telemetry (TLM) word. Each TLM word shall be 30 bits long, occur every 6 seconds in the data frame and be the first word in each subframe. The TLM format shall be as shown in Figure B-3. Each TLM word shall begin with a preamble, followed by 23 reserved bits and 6 parity bits.

3.1.1.2.5 Handover word (HOW). The HOW shall be 30 bits long and shall be the second word in each subframe/page, immediately following the TLM word. A HOW shall occur every 6 seconds in the data frame. The HOW format and content shall be as shown in Figure B-4. The full time-of-week (TOW) count shall consist of the 19 LSBs of the 29-bit Z-count (3.1.1.2.6). The HOW shall begin with the 17 MSBs of the TOW count. These 17 bits shall correspond to the TOW count at the 1.5-second epoch that occurs at the start (leading edge) of the next following subframe.

3.1.1.2.5.1 Bit 18. On satellites designed by configuration code 001, bit 18 shall be an “alert” flag. When this flag is raised (bit 18 is a “1”), it shall indicate to the user that the satellite user range accuracy (URA) may be worse than indicated in subframe 1 and that use of the satellite is at the user’s risks.

*All figures are located at the end of the appendix.

Table B-1. Code phase assignments

Satellite ID number	GPS PRN signal	G2 delay (chips)	First 10 chips octal*
1	1	5	1440
2	2	6	2320
3	3	7	1710
4	4	8	1744
5	5	17	1133
6	6	18	1455
7	7	139	1131
8	8	140	1454
9	9	141	2326
10	10	251	1504
11	11	252	2342
12	12	254	1750
13	13	255	1764
14	14	256	1772
15	15	257	1775
23	23	258	1776
17	17	469	1156
18	18	470	1467
19	19	471	2333
20	20	472	1715
21	21	473	1746
22	22	474	1763
23	23	509	1063
24	24	512	1706
25	25	513	1743

26	26	514	1761
27	27	515	1770
28	28	523	1774
29	29	859	1127
30	30	860	1453
31	31	861	2325
32	32	862	1712
***	33	863	1745
***	34**	950	1713
***	35	947	1134
***	36	948	1456
***	37**	950	1713

* In the octal notation for the first 10 chips of the C/A code as shown in this column, the first digit represents a “1” for the first chip and

the last three digits are the conventional octal representation of the remaining 9 chips (e.g. the first 10 chips of the C/A code for pseudo-random noise (PRN) signal assembly 1 are: 1100100000).

** C/A codes 34 and 37 are common.

*** PRN signal assemblies 33 through 37 are reserved for other uses (e.g. ground transmitters).

3.1.1.2.5.2 Bit 19. Bit 19 shall be reserved.

3.1.1.2.5.3 Bits 20, 21 and 22. Bits 20, 21 and 22 of the HOW shall provide the identification (ID) of the subframe in which that particular HOW is the second word. The ID code shall be as defined below:

ID	Code
1	001
2	010
3	011
4	100
5	101

3.1.1.2.6 Satellite Z-count. Each satellite shall internally derive a 1.5-second epoch that shall contain a convenient unit for precisely counting and communicating time. Time stated in this manner shall be referred to as a Z-count. The Z-count shall be provided to the user as a 29-bit binary number consisting of two parts as follows.

3.1.1.2.6.1 Time-of-week (TOW) count. The binary number represented by the 19 LSBs of the Z-count shall be referred to as the TOW count and is defined as being equal to the number of 1.5-second epochs that have occurred since the transition from the previous week. The count shall be short-cycled such that the range of the TOW count is from 0 to 403 199 1.5-second epochs (equalling one week) and shall be reset to zero at the end of each week. The TOW count's zero state shall be the 1.5-second epoch that is coincident with the start of the present week. A truncated version of the TOW count, consisting of its 17 MSBs, shall be contained in the HOW of the L1 downlink data stream. The relationship between the actual TOW count and its truncated HOW version shall be as indicated in Figure B-5.

Note.— The above-mentioned epoch occurs at (approximately) midnight Saturday night/Sunday morning, where midnight is defined as 0000 hours on the UTC scale which is nominally referenced to the Greenwich Meridian.

3.1.1.2.6.2 Week count. The 10 MSBs of the Z-count shall be a binary representation of the sequential number assigned to the present GPS week (Modulo 1024). The range of this count shall be from 0 to 1 023. Its zero state shall be that week which starts with the 1.5-second epoch occurring at (approximately) the UTC zero time point (3.1.4). At the expiration of GPS week number 1 023, the GPS week number shall roll over to zero. The previous 1 024 weeks in conversions from GPS time to a calendar date shall be accounted for by the user.

3.1.1.3 DATA CONTENT

3.1.1.3.1 Subframe 1 — satellite clock and health data. The content of words 3 through 10 of subframe 1 shall contain the clock parameters and other data as indicated in Table B-2. The parameters in a data set shall be valid during the interval of time in which they are transmitted and shall remain valid for an additional period of time after transmission of the next data set has started.

3.1.1.3.1.1 Week number. The 10 MSBs of word 3 shall contain the 10 MSBs of the 29-bit Z-count and shall represent the number of the current GPS week at the start of the data set transmission interval with all zeros indicating week "zero." The GPS week number shall increment at each end/start of week epoch.

3.1.1.3.1.2 User range accuracy (URA). Bits 13 through 23 of word 3 shall provide the predicted satellite URA as shown in Table B-3.

Note 1.— The URA does not include error estimates due to inaccuracies of the single-frequency ionospheric delay model.

Note 2.— The URA is a statistical indicator of the contribution of the apparent clock and ephemeris prediction accuracies to the ranging accuracies obtainable with a specific satellite based on historical data.

Table B-2. Subframe 1 parameters

Parameter	Number of bits**	Scale factor (LSB)	Effective range***	Units
Week number	10	1		weeks
Satellite accuracy	4			
Satellite health	6	1		discretes
TGD	8*	2^{-31}		seconds
IODC	10			
toc	23	2^4	604 784	seconds
af2	8*	2^{-55}		seconds/second ²
af1	23*	2^{-43}		seconds/second
af0	22*	2^{-31}		seconds

* Parameters so indicated are two's complement, with the sign bit (+ or -) occupying the MSB.

** See Figure B-6 for complete bit allocation.

Unless otherwise indicated in this column, effective range is the maximum range

Table B-3. User range accuracy

URA	Accuracy
0	2 m
1	2.8 m
2	4 m
3	5.7 m
4	8 m
5	11.3 m
6	23 m
7	32 m

8	64 m
9	128 m
10	256 m
11	512 m
12	1 024 m
13	2 048 m
14	4 096 m
15	Do not use

3.1.1.3.1.3 Health. The transmitting satellite 6-bit health indication shall be provided by bits 17 through 22 of word 3.

The MSB shall indicate a summary of the health of the navigation data, where:

a) 0 = all navigation data are valid; and

b) 1 = some of the navigation data are not valid.

The 5 LSBs shall indicate the health of the signal components in accordance with 3.1.1.3.3.4. The health indication shall be provided relative to the capabilities of each satellite as designated by the configuration code in 3.1.1.3.3.5. Any satellite that does not have a certain capability shall be indicated as “healthy” if the lack of this capability is inherent in its design or it has been configured into a mode which is normal from a receiver standpoint and does not require that capability. Additional health data shall be given in subframes 4 and 5.

Note.— The data given in subframe 1 may differ from that shown in subframes 4 and/or 5 of other satellites since the latter may be updated at a different time.

3.1.1.3.1.4 Issue of data, clock (IODC). Bits 23 and 24 of word 3 in subframe 1 shall be the 2 MSBs of the 10-bit IODC term. Bits 1 through 8 of word 8 in subframe 1 shall contain the 8 LSBs of the IODC. The IODC shall indicate the issue number of data set. The transmitted IODC shall be different from any value transmitted by the satellite during the preceding 7 days.

Note.— The relationship between the IODC and the Issue of Data, Ephemeris (IODE) terms is defined in 3.1.1.3.2.2.

3.1.1.3.1.5 Estimated group delay differential. Bits 17 through 24 of word 7 shall contain the correction term, TGD, to account for the effect of satellite group delay differential.

Note.— TGD does not include any C/A to P(Y) code relative group delay error.

3.1.1.3.1.6 Satellite clock correction parameters. Bits 9 through 24 of word 8, bits 1 through 24 of word 9, and bits 1 through 22 of word 10 shall contain the parameters needed by the users for apparent satellite clock correction (toc, af2, af1 and af0).

3.1.1.3.1.7 Reserved data fields. Reserved data fields shall be as indicated in Table B-4. All reserved data fields shall support valid parity within their respective words.

3.1.1.3.2 Subframes 2 and 3 — satellite ephemeris data. Subframes 2 and 3 shall contain the ephemeris representation of the transmitting satellite.

3.1.1.3.2.1 Ephemeris parameters. The ephemeris parameters shall be as indicated in Table B-5. For each parameter in subframe 2 and 3, the number of bits, the scale factor of the LSB, the range, and the units shall be as specified in Table B-6.

3.1.1.3.2.2 Issue of data, ephemeris (IODE). The IODE shall be an 8-bit number equal to the 8 LSBs of the 10-bit IODC of the same data set. The IODE shall be provided in both subframes 2 and 3 for the purpose of comparison with the 8 LSBs of the IODC term in subframe 1. Whenever these three terms do not match, as a result of a data set cutover, new data shall be collected. The transmitted IODE shall be different from any value transmitted by the satellite during the preceding six hours (Note 1). Any change in the subframe 2 and 3 data shall be accomplished in concert with a change in both IODE words. Change to new data sets shall occur only on hour boundaries except for the first data set of a new upload. Additionally, the toe value, for at least the first data set transmitted by a satellite after an upload, shall be different from that transmitted prior to the change (Note 2).

Table B-4. Subframe 1 reserved data fields

Word	Bit
3	11–12
4	1–24
5	1–24
6	1–24
7	1–23

Table B-5. Ephemeris data

M0	Mean anomaly at reference time
n	Mean motion difference from computed value
e	Eccentricity
\sqrt{A}	Square root of the semi-major axis

OMEGA ₀	Longitude of ascending node of orbit plane at weekly epoch
i ₀	Inclination angle at reference time
ω	Argument of perigee
OMEGADOT	Rate of right ascension
iDOT	Rate of inclination angle
Cuc	Amplitude of the cosine harmonic correction term to the argument of latitude
Cus	Amplitude of the sine harmonic correction term to the argument of latitude
Crc	Amplitude of the cosine harmonic correction term to the orbit radius
Crs	Amplitude of the sine harmonic correction term to the orbit radius
Cic	Amplitude of the cosine harmonic correction term to the angle of inclination
Cis	Amplitude of the sine harmonic correction term to the angle of inclination
toe	Reference time, ephemeris
IODE	Issue of data, ephemeris

Table B-6. Ephemeris parameters

Parameter	Number of bits**	Scale factor (LSB)	Effective range***	Units
IODE	8			
Crs	23*	2 ⁻⁵		metres
n	23*	2 ⁻⁴³		semi-circles/second
M0	32*	2 ⁻³¹		semi-circles
Cuc	23*	2 ⁻²⁹		radians
e	32	2 ⁻³³	0.03	dimensionless
Cus	23*	2 ⁻²⁹		radians
— √A	32	2 ⁻¹⁹		metres ^{1/2}

toe	23	2^4	604 784	seconds
Cic	23*	2^{-29}		radians
OMEGA ₀	32*	2^{-31}		semi-circles
Cis	23*	2^{-29}		radians
i ₀	32*	2^{-31}		semi-circles
Crc	23*	2^{-5}		metres
ω	32*	2^{-31}		semi-circles
OMEGADOT	24*	2^{-43}		semi-circles/second
iDOT	14*	2^{-43}		semi-circles/second

* Parameters so indicated are two's complement, with the sign bit (+ or -) occupying the MSB.

** See Figure B-6 for complete bit allocation in subframe.

*** Unless otherwise indicated in this column, effective range is the maximum range attainable with the indicated bit allocation and scale factor.

Note 1.— The IODE/IODC terms provide the receiver with a means for detecting any changes in the ephemeris/clock representation parameters.

Note 2.— The first data set may change (3.1.1.2.2) at any time during the hour and therefore may be transmitted by the satellite for less than 1 hour.

3.1.1.3.2.3 Reserved data fields. Within word 10, subframe 2, bits 17 through 22 shall be reserved. Reserved data fields shall support the valid parity within their respective words.

3.1.1.3.3 Subframes 4 and 5 — support data. Both subframes 4 and 5 shall be subcommutated 25 times each. With the possible exception of “reserved” pages and explicit repeats, each page shall contain different data in words 3 through 10. The pages of subframe 4 shall use 6 different formats, and the pages of subframe 5 shall use two different formats as indicated in Figure B-6.

Pages of subframe 4 shall be as follows:

a) Pages 2, 3, 4, 5, 7, 8, 9 and 10: almanac data for satellites 25 through 32 respectively. If the 6-bit health status word of page 25 is set to 6 “ones” (3.1.1.3.3.4) then the satellite ID of the page shall not have a value in the range of 25 through 32;

Note.— These pages may be designed for other functions. The format and content for each page is defined by the satellite ID of that page.

b) Page 17: special messages;

- c) Page 18: ionospheric and UTC data;
- d) Page 25: satellite configurations for 32 satellites; and
- e) Pages 1, 6, 11, 12, 13, 14, 15, 23, 19, 20, 21, 22, 23 and 24: reserved.

Pages of subframe 5 shall be as follows:

- a) Pages 1 through 24: almanac data for satellite 1 through 24; and
- b) Page 25: satellite health data for satellite 1 through 24, the almanac reference time and the almanac reference week number.

3.1.1.3.3.1 Data ID. The two MSBs of word 3 in each page shall contain the data ID that defines the applicable GPS navigation data structure. The data ID shall be as indicated in Table B-7 in accordance with the following:

- a) for those pages which are assigned to contain the almanac data of one specific satellite, the data ID shall define the data structure utilized by that satellite whose almanac data are contained in that page;
- b) for all other pages, the data ID shall denote the data structure of the transmitting satellite; and
- c) data ID “1” (denoted by binary state 00) shall not be used.

3.1.1.3.3.2 Satellite ID. The satellite ID shall be provided by bits 3 through 8 of word 3 in each page. The satellite IDs shall be utilized two ways:

- a) for those pages which contain the almanac data of a given satellite, the satellite ID shall be the same number that is assigned the PRN code phase of that satellite in accordance with Table B-1; and
- b) for all other pages the satellite ID assigned in accordance with Table B-7 shall serve as the “page ID”. IDs 1 through 32 shall be assigned to those pages which contain the almanac data of specific satellites (pages 1 through 24 of subframe 5 and pages 2 through 5, and 7 through 10 of subframe 4). The “0” ID (binary all zeros) shall be assigned to indicate a dummy satellite, while IDs 51 through 63 shall be utilized for pages containing other than almanac data for a specific satellite (Notes 1 and 2).

Note 1.— Specific IDs are reserved for each page of subframes 4 and 5; however, the satellite ID of pages 2, 3, 4, 5, 7, 8, 9 and 10 of subframe 4 may change for each page to reflect the alternate contents for that page.

Note 2.— The remaining IDs (33 through 50) are unassigned.

Table B-7. Data IDs and satellite IDs in subframes 4 and 5

Page	Data ID	Subframe 4		Subframe 5	
		Satellite ID*	Data ID	Satellite ID*	Data ID
1	***	57	**	1	
2****	**	25	**	2	
3****	**	26	**	3	
4****	**	27	**	4	
5****	**	28	**	5	
6	***	57	**	6	
7****	**	29	**	7	
8****	**	30	**	8	
9****	**	31	**	9	
10****	**	32	**	10	
11	***	57	**	11	
12	***	62	**	12	
13	***	52	**	13	
14	***	53	**	14	
15	***	54	**	15	
23	***	57	**	23	
17	***	55	**	17	
18	***	56	**	18	
19	***	58*****	**	19	
20	***	59*****	**	20	
21	***	57	**	21	
22	***	60*****	**	22	
23	***	61*****	**	23	
24	***	62	**	24	
25	***	63	***	51	

* "0" indicates "dummy" satellite. When using "0" to indicate a dummy satellite, the data ID of the transmitting satellite is used.

** Data ID of that satellite whose satellite ID appears in that page.

*** Data ID of transmitting satellite.

**** Pages 2, 3, 4, 5, 7, 8, 9 and 10 of subframe 4 may contain almanac data for satellites 25 through 32, respectively, or data for other functions as identified by a different satellite ID from the value shown.

***** Satellite ID may vary.

3.1.1.3.3.3 Almanac. Pages 1 through 24 of subframe 5, as well as pages 2 through 5 and 7 through 10 of subframe 4 shall contain the almanac data and a satellite health status word (3.1.1.3.3.4) for up to 32 satellites. The almanac data shall be a reduced-precision subset of the clock and ephemeris parameters. The data shall occupy all bits of words 3 through 10 of each page except the 8 MSBs of word 3 (data ID and satellite ID), bits 17 through 24 of word 5 (satellite health), and the 50 bits devoted to parity. The number of bits, the scale factor (LSB), the range and the units of the almanac parameters shall be as indicated in Table B-8. The almanac message for any dummy satellite shall contain alternating “ones” and “zeros” with a valid parity.

3.1.1.3.3.3.1 Almanac reference time. The almanac reference time, toa , shall be a multiple of 212 seconds occurring approximately 70 hours after the first valid transmission time for this almanac data set. The almanac shall be updated often enough to ensure that GPS time, t , will differ from toa by less than 3.5 days during the transmission period. The almanac parameters shall be updated at least once every 6 days during normal operations.

3.1.1.3.3.3.2 Almanac time parameters. The almanac time parameters shall consist of an 11-bit constant term ($af0$) and an 11-bit first order term ($af1$).

3.1.1.3.3.3.3 Almanac reference week. Bits 17 through 24 of word 3 in page 25 of subframe 5 shall indicate the number of the week (WNa) to which the almanac reference time (toa) is referenced. The WNa term shall consist of the 8 LSBs of the full week number. Bits 9 through 23 of word 3 in page 25 of subframe 5 shall contain the value of toa that is referenced to this WNa .

3.1.1.3.3.4 Health summary. Subframes 4 and 5 shall contain two types of satellite health data:

a) each of the 32 pages that contain the clock/ephemeris related almanac data shall provide an 8-bit satellite health status word regarding the satellite whose almanac data they carry; and

b) the 25th pages of subframes 4 and 5 jointly shall contain 6-bit health data for up to 32 satellites.

3.1.1.3.3.4.1 The 8-bit health status words shall occupy bits 17 through 24 of word 5 in those 32 pages that contain the almanac data for individual satellites. The 6-bit health status words shall occupy the 24 MSBs of words 4 through 9 in page 25 of subframe 5, and bits 19 through 24 of word 8, the 24 MSBs of word 9, and the 18 MSBs of word 10 in page 25 of subframe 4.

Table B-8. Almanac parameters

Number	Scale factor	Effective
--------	--------------	-----------

Parameter	of bits**	(LSB)	range***	Units
e	23	2^{-21}		dimensionless
toa	8	2^{12}	602 112	seconds
δ_i ****	23*	2^{-19}		semi-circles
OMEGADOT	23*	2^{-38}		semi-circles/second
—				
\sqrt{A}	24*	2^{-11}		metres ^{1/2}
OMEGA ₀	24*	2^{-23}		semi-circles
ω	24*	2^{-23}		semi-circles
M ₀	24*	2^{-23}		semi-circles
af0	11*	2^{-20}		seconds
af1	11*	2^{-38}		seconds/second

* Parameters so indicated are two's complement, with the sign bit (+ or -) occupying the MSB.

** See Figure B-6 for complete bit allocation in subframe.

*** Unless otherwise indicated in this column, effective range is the maximum range attainable with the indicated bit allocation and scale factor.

**** Relative to $i_0 = 0.30$ semi-circles.

3.1.1.3.3.4.2 The 3 MSBs of the 8-bit health status words shall indicate health of the navigation data in accordance with the code given in Table B-9. The 6-bit words shall provide a 1-bit summary of the navigation data's health status in the MSB position in accordance with 3.1.1.3.1.3. The 5 LSBs of both the 8-bit and the 6-bit health status words shall provide the health status of the satellite's signal components in accordance with the code given in Table B-10.

Table B-9. Navigation data health indication

Bit position i			Indication
137	138	139	
0	0	0	ALL DATA OK
0	0	1	PARITY FAILURE — some or all parity bad
0	1	0	TLM/HOW FORMAT PROBLEM — any departure from standard format

			(e.g. preamble misplaced and/or incorrect), except for incorrect Z-count, as reported
			in HOW
0	1	1	Z-COUNT in HOW BAD — any problem with Z-count value not reflecting actual code phase
1	0	0	SUBFRAMES 1, 2, 3 — one or more elements in words 3 through 10 of one or more subframes are bad
1	0	1	SUBFRAMES 4, 5 — one or more elements in words 3 through 10 of one or more subframes are bad
1	1	0	ALL UPLOADED DATA BAD — one or more elements in words 3 through 10 of any one (or more) subframes are bad
1	1	1	ALL DATA BAD — TLM word and/or HOW and one or more elements in any one (or more) subframes are bad

Table B-10. Codes for health of satellite signal components

MSB		LSB		Indication
0	0	0	0	ALL SIGNALS OK
1	1	1	0	SATELLITE IS TEMPORARILY OUT — do not use this satellite during current pass ____
1	1	1	0	SATELLITE WILL BE TEMPORARILY OUT — use with caution ____
1	1	1	1	SPARE
1	1	1	1	MORE THAN ONE COMBINATION WOULD BE REQUIRED TO DESCRIBE ANOMALIES, EXCEPT THOSE MARKED BY ____
All other combinations				SATELLITE EXPERIENCING CODE MODULATION AND/OR SIGNAL POWER LEVEL TRANSMISSION PROBLEMS. The user may experience intermittent tracking problems if satellite is not properly acquired.

3.1.1.3.3.4.3 A special meaning shall be assigned, to the 6 “ones” combination of the 6-bit health status words in the 25th pages of subframes 4 and 5; it shall indicate that “the satellite which has that ID is not available and there may be no data regarding that satellite in the page of subframe 4 or 5 that is assigned to normally contain the almanac data of that satellite”.

Note.— This special meaning applies to the 25th pages of subframes 4 and 5 only. There may be data regarding another satellite in the almanac page referred to above as defined in 3.1.1.3.3.3.

3.1.1.3.3.4.4 The health indication shall be provided relative to the capabilities of each satellite as designated by the configuration code in 3.1.1.3.3.5. Accordingly, any satellite that does not have a certain capability shall be indicated as “healthy” if the lack of this capability is inherent in its design or it has been configured into a mode which is normal from a receiver standpoint and does not require that capability. The predicted health data shall be updated at the time of upload.

Note 1.— The transmitted health data may not correspond to the actual health of the transmitting satellite or other satellites in the constellation.

Note 2.— The data given in subframes 1, 4 and 5 of the other satellites may differ from that shown in subframes 4 and/or 5 since the latter may be updated at a different time.

3.1.1.3.3.5 Satellite configuration summary. Page 25 of subframe 4 shall contain a 4-bit-long term for each of up to 32 satellites to indicate the configuration code of each satellite. These 4-bit terms shall occupy bits 9 through 24 of words 3, the 24 MSBs of words 4 through 7, and the 23 MSBs of word 8, all in page 25 of subframe 4. The MSB of each 4-bit term shall indicate whether anti-spoofing is activated (MSB = 1) or not activated (MSB = 0). The 3 LSBs shall indicate the configuration of each satellite using the following code:

Code	Satellite configuration
1	Block II/IIA/IIR satellite
10	Block IIR-M satellite
11	Block IIF satellite

3.1.1.3.3.6 UTC parameters. Page 18 of subframe 4 shall include:

- a) the parameters needed to relate GPS time to UTC time; and
- b) notice to the user regarding the scheduled future or past (relative to navigation message upload) value of the delta time due to leap seconds (tLSF), together with the week number (WNLSF) and the day number (DN) at the end of which the leap second becomes effective. “Day one” shall be the first day relative to the end/start of week and the WNLSF value consists of the 8 LSBs of the full week number. The absolute value of the difference between the untruncated WN and WNLSF values shall not exceed 127.

Note.— The user is expected to account for the truncated nature of this parameter as well as truncation of WN, WNt and WNLSF due to rollover of the full week number (3.1.1.2.6.2).

3.1.1.3.3.6.1 The 24 MSBs of words 6 through 9, and the 8 MSBs of word 10 in page 18 of subframe 4 shall contain the parameters related to correlating UTC time with GPS time. The bit length, scale factors, ranges, and units of these parameters shall be as specified in Table B-11.

3.1.1.3.3.7 Ionospheric parameters. The ionospheric parameters that allow the GPS SPS user to utilize the ionospheric model for computation of the ionospheric delay shall be contained in page 18 of subframe 4 as specified in Table B-12.

3.1.1.3.3.8 Special message. Page 17 of subframe 4 shall be reserved for special messages.

Table B-11. UTC parameters

Parameter	Number of bits**	Scale factor (LSB)	Effective range***	Units
A ₀	32*	2 ⁻³⁰		seconds
A ₁	24*	2 ⁻⁵⁰		seconds/second
tLS	8*	1		seconds
tot	8	2 ¹²	602 112	seconds
WN _t	8	1		weeks
WNLSF	8	1		weeks
DN	8****	1	7	days
tLSF	8*	1		seconds

* Parameters so indicated are two's complement, with the sign bit (+ or -) occupying the MSB.

** See Figure B-6 for complete bit allocation in subframe.

*** Unless otherwise indicated in this column, effective range is the maximum range attainable with the indicated bit allocation and scale factor.

**** Right justified.

Table B-12. Ionospheric parameters

Parameter	Number of bits**	Scale factor (LSB)	Effective range***	Units
α ₀	8*	2 ⁻³⁰		seconds
α ₁	8*	2 ⁻²⁷		seconds/semi-circle
α ₂	8*	2 ⁻²⁴		seconds/semi-circle ²
α ₃	8*	2 ⁻²⁴		seconds/semi-circle ³
β ₀	8*	2 ¹¹		seconds
β ₁	8*	2 ¹⁴		seconds/semi-circle
β ₂	8*	2 ²³		seconds/semi-circle ²
β ₃	8*	2 ²³		seconds/semi-circle ³

- * Parameters so indicated are two's complement, with the sign bit (+ or -) occupying the MSB.
- ** See Figure B-6 for complete bit allocation in subframe.
- *** Unless otherwise indicated in this column, effective range is the maximum range attainable with the indicated bit allocation and scale factor.

3.1.1.3.3.9 Reserved data fields. All bits of words 3 through 10, except the 58 bits used for data ID, satellite (page) ID, parity (six LSBs of each word) and parity computation (bits 23 and 24 of word 10) of pages 1, 6, 11, 12, 13, 14, 15, 23, 19, 20, 21, 22, 23 and 24 of subframe 4, and those almanac pages assigned satellite ID of zero shall be designated as reserved. Other reserved bits in subframes 4 and 5 shall be as shown in Table B-13. Reserved bit positions of each word shall contain a pattern of alternating ones and zeros with a valid word parity.

3.1.2 DEFINITIONS OF PROTOCOLS FOR DATA APPLICATION

Note.— This section defines the inter-relationships of the data broadcast message parameters. It provides definitions of parameters that are not transmitted, but are used by either or both non-aircraft and aircraft elements, and that define terms applied to determine the navigation solution and its integrity.

Table B-13. Reserved bits in subframes 4 and 5

Subframe	Pages	Words	Reserved bit position in word	
4	17	10	17	- 22
4	18	10	9	- 22
4	25	8	17	- 18
4	25	10	19	- 22
5	25	10	4	- 22

Table B-14. Parity encoding algorithms

D_1	$=$	d_1	\oplus	D^{*30}
D_2	$=$	d_2	\oplus	D^{*30}
D_3	$=$	d_3	\oplus	D^{*30}
•		•		
•		•		
•		•		
•		•		
D_{24}	$=$	d_{24}	\oplus	D^{*30}

$$\begin{aligned}
 D_{25} &= D_{29}^* \oplus d_1 \oplus d_2 \oplus d_3 \oplus d_5 \oplus d_6 \oplus d_{10} \oplus d_{11} \oplus d_{12} \oplus d_{13} \oplus d_{14} \oplus d_{17} \oplus d_{18} \oplus d_{20} \oplus d_{23} \\
 D_{26} &= D_{30}^* \oplus d_2 \oplus d_3 \oplus d_4 \oplus d_6 \oplus d_7 \oplus d_{11} \oplus d_{12} \oplus d_{13} \oplus d_{14} \oplus d_{15} \oplus d_{18} \oplus d_{19} \oplus d_{21} \oplus d_{24} \\
 D_{27} &= D_{29}^* \oplus d_1 \oplus d_3 \oplus d_4 \oplus d_5 \oplus d_7 \oplus d_8 \oplus d_{12} \oplus d_{13} \oplus d_{14} \oplus d_{15} \oplus d_{23} \oplus d_{19} \oplus d_{20} \oplus d_{22} \\
 D_{28} &= D_{30}^* \oplus d_2 \oplus d_4 \oplus d_5 \oplus d_6 \oplus d_8 \oplus d_9 \oplus d_{13} \oplus d_{14} \oplus d_{15} \oplus d_{23} \oplus d_{17} \oplus d_{20} \oplus d_{21} \oplus d_{23} \\
 &= D_{30}^* \oplus d_1 \oplus d_3 \oplus d_5 \oplus d_6 \oplus d_7 \oplus d_9 \oplus d_{10} \oplus d_{14} \oplus d_{15} \oplus d_{23} \oplus d_{17} \oplus d_{18} \oplus d_{21} \oplus d_{22} \oplus d_{24} \\
 D_{29} &= d_{24} \\
 D_{30} &= D_{29}^* \oplus d_3 \oplus d_5 \oplus d_6 \oplus d_8 \oplus d_9 \oplus d_{10} \oplus d_{11} \oplus d_{13} \oplus d_{15} \oplus d_{19} \oplus d_{22} \oplus d_{23} \oplus d_{24}
 \end{aligned}$$

where:

$D_1, D_2, D_3, \dots, D_{29}, D_{30}$ are the bits transmitted by the satellite;

D_{25}, \dots, D_{30} are the computed parity bits;

d_1, d_2, \dots, d_{24} are the source data bits;

\oplus is the Modulo-2 or “Exclusive-Or” operation; and

* is used to identify the last two bits of the previous word of the subframe.

3.1.2.1 *Parity algorithm.* GPS parity algorithms are defined as indicated in Table B-14.

3.1.2.2 *Satellite clock correction parameters.* GPS system time t is defined as:

$$t = \text{tsv} - (\Delta\text{tsv})L_1$$

where

t = GPS system time (corrected for beginning and end-of-week crossovers);

tsv = satellite time at transmission of the message;

$(\text{tsv})L_1$ = the satellite PRN code phase offset;

$$(\text{tsv})L_1 = a_{f0} + a_{f1}(t - t_{oc}) + a_{f2}(t - t_{oc})^2 + t_r - T_{GD}$$

where

a_{f0}, a_{f1} and a_{f2} and t_{oc} , are contained in subframe 1; and

t_r = the relativistic correction term (seconds)

$t_r = F_e \sqrt{A} \sin E_k$

where

e and A are contained in subframes 2 and 3;

E_k is defined in Table B-15; and

$$F = \frac{-2(\mu)^{1/2}}{c^2} = -4.442807633(10)^{-10} \text{ s/m}^2$$

where

μ = WGS-84 universal gravitational parameter ($3.986005 \times 10^{14} \text{ m}^3/\text{s}^2$)
 c = the speed of light in a vacuum ($2.99792458 \times 10^8 \text{ m/s}$)

Note.— The value of t is intended to account for the beginning or end-of-week crossovers. That is, if the quantity $t-t_{oc}$ is greater than 302 400 seconds, subtract 604 800 seconds from t . If the quantity $t-t_{oc}$ is less than -302 400 seconds, add 604 800 seconds to t .

3.1.2.3 *Satellite position.* The current satellite position (X_k, Y_k, Z_k) is defined as shown in Table B-15.

3.1.2.4 *Ionospheric correction.* The ionospheric correction (T_{iono}) is defined as:

$$T_{iono} = 510^{-9} \text{ AMP } 1 - \frac{x^2}{2} - \frac{|x|}{1.57} \text{ seconds}$$

$$F = 510^{-9}$$

Where,

$$\text{AMP } \alpha_n = \text{AMP } \alpha_{n,m} \text{ seconds}$$

$$\text{si AMP } 0, \text{ AMP}$$

$$x = \frac{2\pi t - 50\,400}{\text{PER}} \text{ (radians)}$$

$$\text{PER } \beta_n = \text{PER } 72\,000 \text{ seconds}$$

$$\text{si PER } 72\,000, \text{ PER } 72\,000$$

$$F = 1.0 + 16.0[0.53 - E]^3$$

α_n and β_n are the satellite transmitted data words with $n = 0, 1, 2$ and 3

$$\lambda_i = \lambda_u + \frac{\psi}{\cos A} \sin A \text{ (semi-circles)}_i$$

$$\varphi_i = \varphi_u + \psi \cos A \text{ (semi-circles)}$$

$$\lambda_i = \lambda_u + \frac{0.416}{E} \sin A \text{ (semi-circles)}$$

$$\varphi_i = \varphi_u + \psi \cos A \text{ (semi-circles)}$$

$$\psi = \frac{0.0137}{E^{0.11}} - 0.022 \text{ (semi-circles)}$$

$t = 4.32 \times 10^4 \lambda_i + \text{GPS time (seconds)}$ where $0 \leq t < 86\,400$,
therefore: if $t \geq 86\,400$ seconds, subtract 86 400 seconds;
and if $t < 0$ seconds, add 86 400 seconds

$E =$ satellite elevation angle

3.1.2.4.1 The terms used in computation of ionospheric delay are as follows:

a) Satellite transmitted terms

α_n = the coefficients of a cubic equation representing the amplitude of the vertical delay (4 coefficients = 8 bits each)

β_n = the coefficients of a cubic equation representing the period of the model (4 coefficients = 8 bits each)

b) Receiver generated terms

E = elevation angle between the user and satellite (semi-circles)

A = azimuth angle between the user and satellite, measured clockwise positive from the true North

(semi-circles)

φ_u = user geodetic latitude (semi-circles) WGS-84

λ_u = user geodetic longitude (semi-circles) WGS-84

GPS time = receiver computed system time

c) Computed terms

x = phase (radians)

F = obliquity factor (dimensionless)

t = local time (seconds)

φ_m

= geomagnetic latitude of the earth projection of the ionospheric intersection point (mean ionospheric

height assumed 350 km) (semi-circles)

λ_i = geomagnetic longitude of the earth projection of the ionospheric intersection point (semi-circles)

φ_i = geomagnetic latitude of the earth projection of the ionospheric intersection point (semi-circles)

= earth's central angle between user position and earth projection of ionospheric intersection point (semi-circles).

Table B-15. Elements of coordinate systems

3.1.3

 This image cannot currently be displayed.

3.1.3.1 GNSS (GPS) RECEIVER

3.1.3.1.1 Satellite exclusion. The receiver shall exclude any marginal or unhealthy satellite.

Note.— Conditions indicating that a satellite is “healthy”, “marginal” or “unhealthy” can be found in the United States Department of Defense, Global Positioning System – Standard Positioning Service – Performance Standard, 4th Edition, September 2008, Section 2.3.2.

3.1.3.1.2 Satellite tracking. The receiver shall provide the capability to continuously track a minimum of four satellites and generate a position solution based upon those measurements.

3.1.3.1.3 Doppler shift. The receiver shall be able to compensate for dynamic Doppler shift effects on nominal SPS signal carrier phase and C/A code measurements. The receiver shall compensate for the Doppler shift that is unique to the anticipated application.

3.1.3.1.4 Resistance to interference. The receiver shall meet the requirements for resistance to interference as specified in Chapter 3, 3.7.

3.1.3.1.5 Application of clock and ephemeris data. The receiver shall ensure that it is using the correct ephemeris and clock data before providing any position solution. The receiver shall monitor the IODC and IODE values, and to update ephemeris and clock databased upon a detected change in one or both of these values. The SPS receiver shall use clock and ephemeris data with corresponding IODC and IODE values for a given satellite.

3.1.4 TIME

GPS time shall be referenced to a UTC (as maintained by the U.S. Naval Observatory) zero time-point defined as midnight on the night of 5 January 1980/morning of 6 January 1980. The largest unit used in stating GPS time shall be 1 week, defined as 604 800 seconds. The GPS time scale shall be maintained to be within 1 microsecond of UTC (Modulo 1 second) after correction for the integer number of leap seconds difference. The navigation data shall contain the requisite data for relating GPS time to UTC.

3.2 Global navigation satellite system (GLONASS)

channel of standard accuracy (CSA) (L1)

Note.— In this section the term GLONASS refers to all satellites in the constellation. Standards relating only to GLONASS-M satellites are qualified accordingly.

3.2.1 NON-AIRCRAFT ELEMENTS

3.2.1.1 RF CHARACTERISTICS

3.2.1.1.1 Carrier frequencies. The nominal values of L1 carrier frequencies shall be as defined by the following expressions:

$$f_{k1} = f_{01} + k f_1$$

where

$k = -7, \dots, 0, 1, \dots, 6$ are carrier numbers (frequency channels) of the signals transmitted by GLONASS satellites in the L1 sub-band; $f_{01} = 1\,602$ MHz; and $f_1 = 0.5625$ MHz. Carrier frequencies shall be coherently derived from a common on-board time/frequency standard. The nominal value of frequency, as observed on the ground, shall be equal to 5.0 MHz. The carrier frequency of a GLONASS satellite shall be within $\pm 2 \times 10^{-11}$ relative to its nominal value f_k .

Note 1.— The nominal values of carrier frequencies for carrier numbers k are given in Table B-23.

*Note 2.— For GLONASS-M satellites, the L2 channel of standard accuracy (CSA) navigation signals will occupy the 1 242.9375 – 1 251.6875 MHz ± 0.511 MHz bandwidth as defined by the following expressions:
 $f_{k2} = f_{02} + k f_2$,*

$f_{02} = 1\,246\text{ MHz}; f_2 = 0.4375\text{ MHz}.$

For any given value of k the ratio of carrier frequencies of L1 and L2 sub-bands will be equal to:

$$-\frac{7}{9}$$

Table B-16. L1 carrier frequencies

Carrier number (see 3.2.1.3.4)	H_n^A	Nominal value of frequency in L1 sub-band (MHz)
06	6	1 605.3750
05	5	1 604.8125
4	4	1 604.2500
3	3	1 603.6875
2	2	1 603.1250
1	1	1 602.5625
0	0	1 602.0000
-1	31	1 601.4375
-2	30	1 600.8750
-3	29	1 600.3125
-4	28	1 599.7500
-5	27	1 599.1875
-6	26	1 598.6250
-7	25	1 598.0625

3.2.1.1.2 Carrier phase noise. The phase noise spectral density of the unmodulated carrier shall be such that a phase locked loop of 10 Hz one-sided noise bandwidth provides the accuracy of carrier phase tracking not worse than 0.1 radian (1 sigma).

3.2.1.1.3 GLONASS pseudo-random code generation. The pseudo-random ranging code shall be a 511-bit sequence that is sampled at the output of the seventh stage of a 9-stage shift register. The initialisation vector to generate this sequence shall be “111111111”. The generating polynomial that corresponds to the 9-stage shift register shall be:

$$G(x) = 1 + x^5 + x^9.$$

3.2.1.1.4 Spurious emissions. The power of the transmitted RF signal beyond the GLONASS allocated bandwidth shall not be more than -40 dB relative to the power of the unmodulated carrier.

Note 1.— GLONASS satellites launched during 1998 to 2005 and beyond use filters limiting out-of-band emissions to the harmful interference limit contained in Recommendation ITU-R RA.769 for the 1 660 – 1 670 MHz band.

Note 2.— GLONASS satellites launched beyond 2005 use filters limiting out-of-band emissions to the harmful interference limit contained in Recommendation ITU-R RA.769 for the 1 610.6 – 1 613.8 MHz and 1 660 – 1 670 MHz bands.

3.2.1.1.5 Correlation loss. The loss in the recovered signal power due to imperfections in the signal modulation and waveform distortion shall not exceed 0.8 dB.

Note.— The loss in signal power is the difference between the broadcast power in a 1.022 MHz bandwidth and the signal power recovered by a noise-free, loss-free receiver with 1-chip correlator spacing and a 1.022 MHz bandwidth.

3.2.1.2 DATA STRUCTURE

3.2.1.2.1 General. The navigation message shall be transmitted as a pattern of digital data which are coded by Hamming code and transformed into relative code. Structurally, the data pattern shall be generated as continuously repeating superframes. The superframe shall consist of the frames and the frames shall consist of the strings. The boundaries of strings, frames and superframes of navigation messages from different GLONASS satellites shall be synchronized within 2 milliseconds.

3.2.1.2.2 Superframe structure. The superframe shall have a 2.5-minute duration and shall consist of 5 frames. Within each superframe a total content of non-immediate information (almanac for 24 GLONASS satellites) shall be transmitted.

Note.— Superframe structure with indication of frame numbers in the superframe and string numbers in the frames is shown in Figure B-7.

3.2.1.2.3 Frame structure. Each frame shall have a 30-second duration and shall consist of 15 strings. Within each frame the total content of immediate information (ephemeris and time parameters) for given satellite and a part of non-immediate information (almanac) shall be transmitted. The frames 1 through 4 shall contain the part of almanac for 20 satellites (5 satellites per frame) and frame 5 shall contain the remainder of almanac for 4 satellites. The almanac for one satellite shall occupy two strings.

Note.— Frame structures are shown in Figures B-8 and B-9.

3.2.1.2.4 String structure. Each string shall have a 2-second duration and shall contain binary chips of data and time mark. During the last 0.3 second within this 2-second interval (at the end of each string)

the time mark shall be transmitted. The time mark (shortened pseudo-random sequence) shall consist of 30 chips with a time duration for each chip of 10 milliseconds and having the following sequence:

111110001101110101000010010110.

During the first 1.7 seconds within this 2-second interval (in the beginning of each string) 85 bits of data (each data bit of a 20 milliseconds duration) shall be transmitted in bi-binary format. The numbers of bits in the string shall be increased from right to left. Along with information bits (bit positions 9 through 84) the check bits of Hamming code (KX) (bit positions 1 through 8) shall be transmitted. The Hamming code shall have a code length of 4. The data of one string shall be separated from the data of adjacent strings by time mark (MB). The words of the data shall be registered by MSB ahead. In each string bit position, 85 shall be an idle chip ("0") and be transmitted first.

3.2.1.2.4.1 Strings 1 through 4. The information contained in strings 1 through 4 of each frame shall correspond to the satellite from which it is transmitted. This information shall not be changed within the superframe.

3.2.1.2.4.2 Strings 5 through 15. Strings 5 through 15 of each frame shall contain GLONASS almanac for 4 or 5 satellites. The information contained in the fifth string shall be repeated in each frame of the superframe.

Note.— String structure is given in Figure B-10.

3.2.1.3 DATA CONTENT

3.2.1.3.1 Ephemeris and time parameters. The ephemeris and time parameters shall be as follows:

m = the string number within the frame;

t_k = the time referenced to the beginning of the frame within the current day. It is calculated according to the satellite time scale. The integer number of hours elapsed since the beginning of the current day is registered in the 5 MSBs. The integer number of minutes elapsed since the beginning of the current hour is registered in the next 6 bits. The number of 30-second intervals elapsed since the beginning of the current minute is registered in the one LSB. The beginning of the day according to the satellite time scale coincides with the beginning of the recurrent superframe;

t_b = the time interval within the current day according to UTC(SU) + 03 hours 00 min. The immediate data transmitted within the frame are referred to the middle of t_b . Duration of the time interval and therefore the maximum value of t_b depends on the value of the flag P1;

$\gamma_n(t_b)$ = the relative deviation of predicted carrier frequency value of n-satellite from the nominal value at the instant t_b , i.e.

$$\gamma_n(t_b) = \frac{f_n(t_b) - f_{Hn}}{f_{Hn}},$$

where

$f_n(t_b)$ = the forecast frequency of n-satellite clocks at an instant t_b ;

f_{Hn} = the nominal value of frequency of n-satellite clocks;

$\tau_n(t_b)$ = the correction to the n-satellite time t_n relative to GLONASS time t_c at an instant t_b , i.e. $\tau_n(t_b) = t_c(t_b) - t_n(t_b)$;

$x_n(t_b), y_n(t_b), z_n(t_b)$ = the coordinates of n-satellite in PZ-90 coordinate system at an instant t_b ;

t_b = the velocity vector components of n-satellite in PZ-90 coordinate system at an instant t_b ;

t_b = the acceleration components of n-satellite in PZ-90 coordinate system at an instant t_b , which are caused by effect of sun and moon;

E_n = an indication of the “age” of the immediate information, i.e. a time interval elapsed since the instant of its calculation (uploading) until the instant t_b for n-satellite;

B_n = the health flag. Values greater than 3 indicate the fact of malfunction of given satellite;

P_1 = a flag indicating the time interval between the current and previous value of the t_b parameters in minutes as shown:

P_1 Time interval between adjacent values of t_b in minutes

0	0
1	30
10	45
11	60

P_2 = a flag indicating whether the value of t_b is odd or even. A value of “1” indicates a 30-minute interval of service information transmit ($t_b = 1, 3, 5 \dots$), a value of “0” indicates a 60-minute interval of service information transmit ($t_b = 2, 6, 10 \dots$);

P_3 = a flag indicating the number of satellites for which an almanac is transmitted within a given frame. “1” corresponds to 5 satellites and “0” corresponds to 4 satellites; and

Δt_n = the time difference between the navigation RF signal transmitted in L2 sub-band and navigation RF signal transmitted in L1 sub-band by given satellite:

$$\Delta t_n = t_{f2} - t_{f1}$$

Where t_{f1} , t_{f2} are the equipment delays in L1 and L2 sub-bands respectively, expressed in units of time.

3.2.1.3.2 Ephemeris and time parameters. The ephemeris and time parameters shall be as indicated in Table B-17. For the words for which numeric values may be positive or negative, the MSB shall be the sign bit. The chip “0” shall correspond to the “+” sign and the chip “1” shall correspond to the “-” sign.

3.2.1.3.3 Arrangement of the ephemeris and time parameters. Arrangements of the ephemeris and time parameters within a frame shall be as indicated in Table B-18.

3.2.1.3.4 *Almanac parameters.* The almanac parameters shall be as follows:

A = an index showing relation of this parameter with the almanac;

$M^A n$ = an index of the modification of n^A -satellite: “00” indicates GLONASS satellite, and “01” indicate GLONASS-M satellite;

τ_c = the GLONASS time scale correction to UTC (SU) time. The correction τ_c is given at the instant of day N^A ;

N^A = the calendar day number within the 4-year period beginning since the leap year. The correction τ_c and

other almanac data (almanac of orbits and almanac of phases) relate to this day number;

- n^A = the slot number occupied by n-satellite;
- H^{An} = the channel number of a carrier frequency of n^A -satellite (Table B-23);
- λ^{An} = the longitude of the first (within the N^A -day) ascending node of n^A -satellite orbit in PZ-9 coordinate system;
- $t\lambda_n$ = the time of the first ascending node passage of n^A -satellite within N^A -day;

Table B-17. Ephemeris and time parameters

Parameter	Number of bits	Scale factor (LSB)	Effective range	Units
m	4	1		dimensionless
	5	1	0 to 23	hours
t_k	6	1	0 to 59	minutes
	1	30	0 or 30	seconds
t_b	7	15	15...1 425	minutes
$\gamma_n(t_b)$	11	2^{-40}	$\pm 2^{-30}$	dimensionless
$\tau_n(t_b)$	22	2^{-30}	$\pm 2^{-9}$	seconds
$x_n(t_b), y_n(t_b), z_n(t_b)$	27	2^{-11}	$\pm 2.7 \times 10^4$	km
$\dot{x}_n(t_b), \dot{y}_n(t_b), \dot{z}_n(t_b)$	24	2^{-20}	± 4.3	km/second
$\ddot{x}_n(t_b), \ddot{y}_n(t_b), \ddot{z}_n(t_b)$	5	2^{-30}	$\pm 6.2 \times 10^{-9}$	km/second ²
E_n	5	1	0 to 31	days
B_n	3	1	0 to 7	dimensionless
P1	2	as detailed in 3.2.1.3.1		
P2	1	1	0; 1	dimensionless
P3	1	1	0; 1	dimensionless
$\Delta\tau_n$	5	2^{-30}	$\pm 13.97 \times 10^{-9}$	seconds

Table B-18. Arrangements of the ephemeris and time parameters within the frame

Parameter	Number of bits	String number within the frame	Bit number within the frame
m	4	1...15	81-84
t_k	12	1	65-76
t_b	7	2	70-76
$\gamma_n(t_b)$	11	3	69-79
$\tau_n(t_b)$	22	4	59-80

$x_n(t_b)$	27	1	9-35
$y_n(t_b)$	27	2	9-35
$z_n(t_b)$	27	3	9-35
$\dot{x}_n(t_b)$	24	1	41-64
$\dot{y}_n(t_b)$	24	2	41-64
$\dot{z}_n(t_b)$	24	3	41-64
$\ddot{x}_n(t_b)$	5	1	36-40
$\ddot{y}_n(t_b)$	5	2	36-40
$\ddot{z}_n(t_b)$	5	3	36-40
E_n	5	4	49-53
B_n	3	2	78-80
P_1	2	1	77-78
P_2	1	2	77
P_3	1	3	80
$\Delta\tau_n$	5	4	54-58

i_n^A = the correction to the mean value of inclination of n^A -satellite at instant of t_{λ}^A (mean value of inclination is equal to 63 degrees);

T_n^A = the correction to the mean value of Draconian period of the n^A -satellite at the instant of t_{λ}^A (mean value of Draconian period T is equal to 43 200 seconds);

ΔT_n^A = the rate of change of Draconian period of n^A -satellite;

ε_n^A = the eccentricity of n^A -satellite at instant of t_{λ}^A ;

ω_n^A = the argument of perigee of n^A -satellite at the instant of t_{λ}^A ;

τ_n^A = the coarse value of n^A -satellite time correction to GLONASS time at instant of t_{λ}^A ;

C_n^A = a generalized “unhealthy flag” of n^A -satellite at instant of almanac upload almanac of orbits and phases. When $C_n = 0$, this indicates that n -satellite is non-operational. When $C_n = 1$, this indicates that n -satellite is operational.

3.2.1.3.5 Partition and coding of almanac parameters. The GLONASS almanac, transmitted within the superframe, shall be partitioned over the superframe, as indicated in Table B-19. The numeric values of almanac parameters shall be positive or negative. The MSB shall be the sign bit, the chip “0” shall correspond to the “+” sign, and the chip “1” shall correspond to the “-” sign. The almanac parameters shall be coded as indicated in Table B-20.

3.2.1.3.6 Arrangement of the almanac parameters. Arrangement of the almanac words within the frame shall be as indicated in Table B-21.

3.2.1.4 CONTENT AND STRUCTURE OF ADDITIONAL DATA TRANSMITTED BY GLONASS-M SATELLITES

3.2.1.4.1 Letter designation of additional data. In addition to the GLONASS data, GLONASS-M satellites shall transmit the following additional data as indicated in Table B-17-A:

n — an index of the satellite transmitting the given navigation signal: it corresponds to a slot number within GLONASS constellation;

h_n — health flag for n -th satellite: “0” indicates the n -th satellite is healthy, “1” indicates the malfunction of the n -th satellite;

$B1$ — coefficient to determine the day (N^A), expressed in seconds;
 $UT1$: it is equal to the difference between $UT1$ and UTC at the beginning of the day;

$B2$ — coefficient to determine the daily change of the difference $UT1$ (expressed in seconds) for a mean sun day.

These coefficients shall be used to transform between $UTC(SU)$ and $UT1$:

$$UT1 = UTC(SU) - UT1,$$

where

$UT1$ — Universal Time referenced to the Mean Greenwich Meridian (taking account of Pole motion),

$UTC(SU)$ — Coordinated Universal Time of the Russian Federation State Standard,

$$UT1 = B1 + B2 \times (N_T - N^A),$$

KP — notification of a forthcoming leap second correction of UTC (± 1 s) as shown:

KP	UTC second correction data
00	No UTC correction at the end of the current quarter
1	UTC correction by plus 1 s at the end of the current quarter
11	UTC correction by minus 1 s at the end of the current quarter

Note.— *GLONASS system timescale correction is usually performed once a year at midnight 00 hours 00 minutes 00 seconds in accordance with the early notification of the International Time Bureau (BIH/BIPM) at the end of a quarter:*

from 31 December to 1 January — first quarter,

from 31 March to 1 April — second quarter,

from 30 June to 1 July — third quarter,

from 30 September to 1 October — fourth quarter

N_T — current date, calendar number of the day within the four-year interval starting from 1 January in a leap year;

Note.— *An example of N_T transformation into the common form of current data information (dd/mm/yy) is presented in Attachment D, 4.2.7.1.*

N_4 — four-year interval number starting from 1996;

F_T — a parameter that provides the predicted satellite user range accuracy at time t_b . Coding is as indicated in Table B-17-B;

M — type of satellite transmitting the navigation signal. 00 refers to a GLONASS satellite; 01 refers to a GLONASS-M satellite;

P4 — flag to show that updated ephemeris parameters are present. “1” indicates that an updated ephemeris or frequency/time parameters have been uploaded by the control segment;

Note.— Updated ephemeris or frequency/time information is transmitted in the next interval after the end of the current interval t_b .

P — technological parameter of control segment indicating the satellite operation mode in respect of time parameters: 00 — τ_c parameter relayed from control segment, τ_{GPS} parameter relayed from control segment;

01 — τ_c parameter relayed from control segment, τ_{GPS} parameter calculated on-board the GLONASS-M satellite; 10 — τ_c parameter calculated on-board the GLONASS-M satellite; τ_{GPS} parameter relayed from control segment;

11 — τ_c parameter calculated on-board the GLONASS-M satellite; τ_{GPS} parameter calculated on-board the GLONASS-M satellite;

τ_{GPS} — correction to GPS time relative to GLONASS time:

$$T_{GPS} - T_{GL} = T + \tau_{GPS},$$

where

T is the integer part, and τ_{GPS} is the fractional part of the difference between the system timescales expressed in seconds.

Note.— The integer part T is determined from the GPS navigation message by the user receiver.

M_n^A — type of satellite n^A : coding “00” indicates a GLONASS satellite, coding “01” indicates a GLONASS-M satellite.

3.2.1.4.2 *Additional data parameters.* Additional data parameters are defined in Tables B-17-A to B-18-A.

3.2.1.4.3 *Location of additional data words within GLONASS-M navigation message.* The required location of additional data words within the GLONASS-M navigation message is defined in Table B-18-A.

Table B-17-A. Additional data parameters

Parameter	No. of bits	Scale factor (LSB)	Effective range	Units
n	5	1	0 to 31	Dimensionless
l_n	1	1	0; 1	Dimensionless
B1	11	2^{-10}	± 0.9	seconds
B2	10	2^{-16}	$(-4.5 \text{ to } 3.5) \times 10^{-3}$	s/mean sun day
KP	2	1	0 to 3	Dimensionless
N_T	11	1	0 to 1 461	days
N_4	5	1	1 to 31	four-year interval
F_T	4		See table B-17-B	
M	2	1	0 to 3	Dimensionless
P4	1	1	0; 1	Dimensionless
P	2	1	00,01,10,11	Dimensionless
τ_{GPS}	22	2^{-30}	$\pm 1.9 \times 10^{-3}$	seconds
M_n^A	2	1	0 to 3	Dimensionless

Frame number Satellite numbers, for which almanac is
within the superframe transmitted within given frame

1	1 to 5
2	6 to 10
3	11 to 15
4	23 to 20
5	21 to 24

Table B-20. Almanac parameters coding

Parameter	Number of bits	Scale factor (LSB)	Effective range	Units
M_n^A	2	1	0 to 3	dimensionless
τ_c	28	2^{-27}	± 1	seconds
N^A	11	1	1 to 1 461	days
n^A	5	1	1 to 24	dimensionless
H_n^A	5	1	0 to 31	dimensionless
λ_n^A	21	2^{-20}	± 1	semi-circles
$t_{\lambda_n^A}$	21	2^{-5}	0 to 44 100	seconds
Δi_n^A	18	2^{-20}	± 0.067	semi-circles
ΔT_n^A	22	2^{-9}	$\pm 3.6 \times 10^3$	seconds/revolution
ΔT_n^A	7	2^{-14}	$\pm 2^{-8}$	seconds/revolution ²
ε_n^A	15	2^{-20}	0 to 0.03	dimensionless
ω_n^A	23	2^{-15}	± 1	semi-circles
$t_{\tau_n^A}$	10	2^{-18}	$\pm 1.9 \times 10^{-3}$	seconds
C_n^A	1	1	0 to 1	dimensionless

Table B-21. Arrangement of almanac parameters within the frame

Parameter	Number of bits	String number within the frame	Bit number within the string
M_n^A	2	6, 8, 10, 12, 14	78-79
τ_c	28	5	42-69
N^A	11	5	70-80
n^A	5	6, 8, 10, 12, 14	73-77
H_n^A	5	7, 9, 11, 13, 15	10-14
λ_n^A	21	6, 8, 10, 12, 14	42-62
$t_{\lambda_n^A}$	21	7, 9, 11, 13, 15	44-64
Δi_n^A	18	6, 8, 10, 12, 14	24-41
ΔT_n^A	22	7, 9, 11, 13, 15	22-43
ΔT_n^A	7	7, 9, 11, 13, 15	15-21
ε_n^A	15	6, 8, 10, 12, 14	9-23

ε^{An}				
ω^{An}	23	7, 9, 11, 13, 15	65–80	
t_r^{An}	10	6, 8, 10, 12, 14	63–72	
C^{An}	1	6, 8, 10, 12, 14	80	

Note.— String numbers of the first four frames within superframe are given. There are no almanac parameters in 14th and 15th strings of 5th frame.

Table B-22. Parity checking algorithm

$b_{85}, b_{84}, \dots, b_{10}, b_9$ are the data bits (position 9 to 85 in the string);

$\beta_1, \beta_2, \dots, \beta_8$ are the check bits of the Hamming code (positions 1 to 8 in the string);

$c_1, c_2, \dots, c_7, c_\Sigma$ are the checksums generated using the following:

$$c_1 = \beta_1 \oplus [\sum_i b_i]_{\text{mod } 2}$$

$i = 9, 10, 12, 13, 15, 17, 19, 20, 22, 24, 26, 28, 30, 32, 34, 35, 37, 39, 41, 43, 45, 47, 49, 51, 53, 55, 57, 59, 61, 63, 65, 66, 68, 70, 72, 74, 76, 78, 80, 82, 84.$

$$c_2 = \beta_2 \oplus [\sum_j b_j]_{\text{mod } 2}$$

$j = 9, 11, 12, 14, 15, 18, 19, 21, 22, 25, 26, 29, 30, 33, 34, 36, 37, 40, 41, 44, 45, 48, 49, 52, 53, 56, 57, 60, 61, 64, 65, 67, 68, 71, 72, 75, 76, 79, 80, 83, 84.$

$$c_3 = \beta_3 \oplus [\sum_k b_k]_{\text{mod } 2}$$

$k = 10, 11, 12, 16, 17, 18, 19, 23, 24, 25, 26, 31, 32, 33, 34, 38, 39, 40, 41, 46, 47, 48, 49, 54, 55, 56, 57, 62, 63, 64, 65, 69, 70, 71, 72, 77, 78, 79, 80, 85.$

$$c_4 = \beta_4 \oplus [\sum_l b_l]_{\text{mod } 2}$$

$l = 13, 14, 15, 16, 17, 18, 19, 27, 28, 29, 30, 31, 32, 33, 34, 42, 43, 44, 45, 46, 47, 48, 49, 58, 59, 60, 61, 62, 63, 64, 65, 73, 74, 75, 76, 77, 78, 79, 80.$

$$c_5 = \beta_5 \oplus [\sum_m b_m]_{\text{mod } 2}$$

$m = 20, 21, 22, 23, 24, 25, 26, 27, 28, 29, 30, 31, 32, 33, 34, 50, 51, 52, 53, 54, 55, 56, 57, 58, 59, 60, 61, 62, 63, 64, 65, 81, 82, 83, 84, 85.$

$$c_6 = \beta_6 \oplus [\sum_n b_n]_{\text{mod } 2}$$

$n = 35, 36, 37, 38, 39, 40, 41, 42, 43, 44, 45, 46, 47, 48, 49, 50, 51, 52, 53, 54, 55, 56, 57, 58, 59, 60, 61, 62, 63, 64, 65.$

$$c_7 = \beta_7 \oplus [\sum_p b_p]_{\text{mod } 2}$$

$p = 66, 67, 68, 69, 70, 71, 72, 73, 74, 75, 76, 77, 78, 79, 80, 81, 82, 83, 84, 85.$

$$c_\Sigma = [\sum_q \beta_q]_{\text{mod } 2} \oplus [\sum_r b_r]_{\text{mod } 2}$$

$q = 1, 2, 3, 4, 5, 6, 7, 8$

$r = 9, 10, 11, 12, 13, 14, 15, 16, 17, 18, 19, 20, 21, 22, 23, 24, 25, 26, 27, 28, 29, 30, 31, 32, 33, 34, 35, 36, 37, 38, 39, 40, 41, 42, 43, 44, 45, 46, 47, 48, 49, 50, 51, 52, 53, 54, 55, 56, 57, 58, 59, 60, 61, 62, 63, 64, 65, 66, 67, 68, 69, 70, 71, 72, 73, 74, 75, 76, 77, 78, 79, 80, 81, 82, 83, 84, 85.$

3.2.2.1 *Parity checking algorithm for data verification.* The algorithm shown in Table B-22 and as detailed below is used to detect and correct an error of 1 bit within the string and to detect an error of 2 or more bits within a string.

3.2.2.1.1 Each string includes the 85 data bits where the 77 MSBs are data chips ($b_{85}, b_{84}, \dots, b_{10}, b_9$), and the 8 LSBs are the check bits of Hamming code length of 4 ($\beta_8, \beta_7, \dots, \beta_2, \beta_1$).

3.2.2.1.2 To correct 1-bit errors within the string the following checksums are generated: (c_1, c_2, \dots, c_7), and to detect 2-bit errors (or more-even-number-of-bits errors) a checksum c_Σ is generated, as shown in Table B-22. The following is used for correcting single errors and detecting multiple errors:

a) A string is considered correct if all checksums (c_1, \dots, c_7 , and c_Σ) are equal to “0”, or if only one of the checksums (c_1, \dots, c_7) is equal to “1” and c_Σ is equal to “1”.

b) If two or more of the checksums (c_1, \dots, c_7) are equal to “1” and c_Σ is equal to “1”, then character “ $b_{i_{cor}}$ ” is corrected to the opposite character in the following bit position:

“ i_{cor} ” = $c_7 c_6 c_5 c_4 c_3 c_2 c_1 + 8 - K$, provided that “ i_{cor} ” ≤ 85 ,

where “ $c_7 c_6 c_5 c_4 c_3 c_2 c_1$ ” is a binary number generated from the checksums (c_1, \dots, c_7) with c_1 being the LSB and c_7 being the MSB. K is the ordinal number of the most significant checksum not equal to “0”.

If $i_{cor} > 85$, then there is an odd number of multiple errors, and the data shall be rejected.

c) If at least one of the checksums (c_1, \dots, c_7) is equal to “1” and c_Σ is equal to “0”, or if all checksums (c_1, \dots, c_7) are equal to “0” but c_Σ is equal to “1”, then there are multiple errors and the data shall be rejected.

3.2.2.2 SATELLITE CLOCK CORRECTION PARAMETERS

3.2.2.2.1 GLONASS system time is determined as:

$$t_{GLONASS} = t_k + \tau_n(t_b) - \gamma_n(t_b) (t_k - t_b)$$

where $t_k, \tau_n(t_b), \gamma_n(t_b)$ are parameters described in 3.2.1.3.1.

3.2.2.2.2 GLONASS time is related to National Time Service of Russia (UTC(SU)) time as indicated below:

$$t_{UTC(SU)} = t_{GLONASS} + \tau_c - 03 \text{ hours } 00 \text{ minutes}$$

where

τ_c is a parameter described in 3.2.1.3.4 and 03 hours 00 minutes is continuous time shift caused by difference between Moscow time and Greenwich time.

3.2.2.3 SATELLITE POSITION

3.2.2.3.1 The current satellite position is defined using ephemeris parameters from GLONASS navigation, as indicated and in Table B-17.

3.2.2.3.2 Recalculation of ephemeris from instant t_b to instant t_i within the interval ($|t_i| = |t_i - t_b| \leq 15$ minutes) is performed using a technique of numeric integration of differential equations describing the motion of the satellites. In the right-hand parts of these equations the accelerations are determined using the gravitational constant μ and the second zonal harmonic of the geopotential J_2^0 which defines polar flattening of the earth, and accelerations due to luni-solar perturbation are taken into account. The equations are integrated in the PZ-90 (3.2.5) coordinate system by applying the Runge-Kutta technique of fourth order, as indicated below:

$$\frac{dx}{dt} = V_x$$

$$\frac{dy}{dt} = -V_y$$

$$\frac{dz}{dt} = V_z$$

$$\frac{d^2x}{dt^2} = -\frac{\mu}{r^3}x - J_0^2 \frac{\mu a^2}{r^5}x - \frac{5z^2}{r^2} + \omega^2 x + 2\omega V_y$$

$$\frac{d^2y}{dt^2} = -\frac{\mu}{r^3}y - J_0^2 \frac{\mu a^2}{r^5}y - \frac{5z^2}{r^2} - \omega^2 y + 2\omega V_x$$

$$\frac{d^2z}{dt^2} = -\frac{\mu}{r^3}z - J_0^2 \frac{\mu a^2}{r^5}z - \frac{5z^2}{r^2}$$

where

- $r = \sqrt{x^2 + y^2 + z^2}$;
- μ = earth's universal gravitational constant ($398\,600.44 \times 10^9 \text{ m}^3/\text{s}^2$);
- a_e = major semi-axis (6 378 136 m);
- J_0^2 = second zonal harmonic of the geopotential ($1\,082\,625.7 \times 10^{-9}$); and
- ω = earth's rotation rate (7.292115×10^{-5} radians/s).

Coordinates $x_n(t_b)$, $y_n(t_b)$, $z_n(t_b)$, and velocity vector components $x'_n(t_b) = V_x$, $y'_n(t_b) = V_y$, $z'_n(t_b) = V_z$ are initial conditions for the integration. Accelerations due to luni-solar perturbation $x''_n(t_b)$, $y''_n(t_b)$, $z''_n(t_b)$ are constant on the integration interval ± 15 minutes.

3.2.3 AIRCRAFT ELEMENTS

3.2.3.1 GNSS (GLONASS) RECEIVER

3.2.3.1.1 Satellite exclusion. The receiver shall exclude any satellite designated unhealthy in the GLONASS navigation message.

3.2.3.1.2 Satellite tracking. The receiver shall provide the capability to continuously track a minimum of four satellites and generate a position solution based upon those measurements.

3.2.3.1.3 Doppler shift. The receiver shall be able to compensate for dynamic Doppler shift effects on nominal GLONASS signal carrier phase and standard code measurements. The receiver shall compensate for the Doppler shift that is unique to the anticipated application.

3.2.3.1.4 Resistance to interference. The receiver shall meet the requirements for resistance to interference as specified in 3.7.

3.2.3.1.4.1 Intrasystem interference. When receiving a navigation signal with frequency channel $k = n$, the interference created by a navigation signal with frequency channel number $k = n - 1$ or $k = n + 1$ shall not

be more than -48 dBc with respect to the minimum specified satellite power at the surface of the earth provided that the satellites transmitting these signals are simultaneously located in user's visibility zone.

Note.— The intrasystem interference is the intercorrelation properties of the ranging pseudo-random signal with regard to frequency division multiple access.

3.2.3.1.5 Application of clock and ephemeris data. The receiver shall ensure that it is using the correct ephemeris and clock data before providing any position solution.

3.2.3.1.6 Leap second correction. Upon GLONASS time leap second correction (see 3.2.1.3.1, tb) the GLONASS receiver shall be capable of:

- a) generating a smooth and valid series of pseudo-range measurements; and
- b) resynchronizing the data string time mark without loss of signal tracking.

3.2.3.1.6.1 After GLONASS time leap second correction the GLONASS receiver shall utilize the UTC time as follows:

- a) utilize the old (prior to the correction) UTC time together with the old ephemeris (transmitted before 00 hours 00 minutes 00 seconds UTC); and
- b) utilize the updated UTC time together with the new ephemeris (transmitted after 00 hours 00 minutes 00 seconds UTC).

3.2.4 TIME

3.2.4.1 For the GLONASS-M satellites, the navigation message shall contain the data necessary to relate UTC(SU) time to UT1. GLONASS time shall be maintained to be within 1 millisecond of UTC(SU) time after correction for the integer number of hours due to GLONASS control segment specific features:

$$| t_{\text{GLONASS}} - (\text{UTC} + 03 \text{ hours } 00 \text{ minutes}) | < 1 \text{ ms}$$

The navigation data shall contain the requisite data to relate GLONASS time to UTC time (as maintained by the National Time Service of Russia, UTC (SU)) within 1 microsecond.

Note 1.— The timescales of GLONASS satellites are periodically compared with central synchronizer time. Corrections to the timescales of GLONASS satellites relative to GLONASS time and UTC(SU) time are computed at the GLONASS ground-based control complex and uploaded to the satellites twice per day.

Note 2.— There is no integer-second difference between GLONASS time and UTC time. The GLONASS timescale is periodically corrected to integer number of seconds simultaneously with UTC corrections which are performed according to the Bureau International de l'Heure notification (leap second correction). These corrections are performed at 00 hours 00 minutes 00 seconds UTC time at midnight at the end of a quarter of the year. Upon the GLONASS leap second correction the time mark within navigation message changes its position (in a continuous timescale) to become synchronized with 2-second epochs of corrected UTC timescale. GLONASS users are notified in advance on these planned corrections. For the GLONASS-M satellites, notification of these corrections is provided to users via the navigation message parameter KP.

3.2.4.2 Accuracy of mutual satellite timescales synchronization shall be 20 nanoseconds (1 sigma) for GLONASS satellites and 8 nanoseconds (1 sigma) for GLONASS-M satellites.

3.2.4.3 The correction to GPS time relative to GLONASS time (or difference between these timescales) broadcast by the GLONASS-M satellites, t_{GPS} , shall not exceed 30 nanoseconds (1 sigma).

Note.— The accuracy of t_{GPS} (30 ns) is determined with reference to the GPS SPS coarse acquisition signal and may be refined upon completion of trials of the GLONASS system using GLONASS-M satellites.

3.2.5 COORDINATE SYSTEM

3.2.5.1 PZ-90 (Parameters of common terrestrial ellipsoid and gravitational field of the earth 1990). The GLONASS broadcast ephemeris shall describe a position of transmitting antenna phase centre of a given satellite in the PZ-90 earth-centred earth-fixed reference frame.

3.2.5.2 *Conversion between PZ-90 and WGS-84.* The following conversion parameters shall be used to obtain position coordinates in WGS-84 from position coordinates in PZ-90 (Version 2):

X	-0.3X
Y	0.0Y
Z _{WGS-84}	0.1Z _{PZ-90}

Note.— X, Y and Z are expressed in metres.

3.2.5.2.1 The conversion error shall not exceed 0.1 metres (1 sigma) along each coordinate axis.

3.3 Combined use of GPS and GLONASS

3.3.1 AIRCRAFT ELEMENTS

3.3.1.1 Combined GNSS receiver. The combined GNSS receiver shall process signals from GPS and GLONASS in accordance with the requirements specified in 3.1.3.1, GPS (GNSS) receiver, and 3.2.3.1, GLONASS (GNSS) receiver.

3.3.1.1.1 Resistance to interference. The combined GNSS receiver shall meet the individual requirements for GPS and GLONASS as specified in 3.7.

3.3.1.2 Antenna(e). GPS and GLONASS signals shall be received through one or more antennae.

Note.— Performance characteristics of GNSS receiver antennae are defined in 3.8.

3.3.1.3 Conversion between coordinate systems. Position information provided by a combined GPS and GLONASS receiver shall be expressed in WGS-84 earth coordinates. The GLONASS satellite position, obtained in PZ-90 coordinate frame, shall be converted to account for the differences between WGS-84 and PZ-90, as defined in 3.2.5.2.

3.3.1.4 GPS/GLONASS time. When combining measurements from GLONASS and GPS, the difference between GLONASS time and GPS time shall be taken into account.

3.4 Aircraft-based augmentation system (ABAS)

Note.— Guidance on ABAS is given in Attachment D, section 5.

3.5 Satellite-based augmentation system (SBAS)

3.5.1 GENERAL

Note.— Parameters in this section are defined in WGS-84.

3.5.2 RF CHARACTERISTICS

3.5.2.1 Carrier frequency stability. The short-term stability of the carrier frequency (square root of the Allan Variance) at the output of the satellite transmit antenna shall be better than 5×10^{-11} over 1 to 10 seconds.

3.5.2.2 Carrier phase noise. The phase noise spectral density of the unmodulated carrier shall be such that a phase locked loop of 10 Hz one-sided noise bandwidth is able to track the carrier to an accuracy of 0.1 radian (1 sigma).

3.5.2.3 Spurious emissions. Spurious emissions shall be at least 40 dB below the unmodulated carrier power over all frequencies.

3.5.2.4 Code/carrier frequency coherence. The short-term (less than 10 seconds) fractional frequency difference between the code phase rate and the carrier frequency shall be less than 5×10^{-11} (standard deviation). Over the long term (less than 100 seconds), the difference between the change in the broadcast code phase, converted to carrier cycles by multiplying the number of code chips by 1 540, and the change in the broadcast carrier phase, in cycles, shall be within one carrier cycle (standard deviation).

Note.— This applies to the output of the satellite transmit antenna and does not include code/carrier divergence due to ionospheric refraction in the downlink propagation path.

3.5.2.5 Correlation loss. The loss in the recovered signal power due to imperfections in the signal modulation and waveform distortion shall not exceed 1 dB.

Note.— The loss in signal power is the difference between the broadcast power in a 2.046 MHz bandwidth and the signal power recovered by a noise-free, loss-free receiver with 1-chip correlator spacing and a 2.046 MHz bandwidth.

3.5.2.6 Maximum code phase deviation. The maximum uncorrected code phase of the broadcast signal shall not deviate from the equivalent SBAS network time (SNT) by more than $\pm 2-20$ seconds.

3.5.2.7 Code/data coherence. Each 2-millisecond symbol shall be synchronous with every other code epoch.

3.5.2.8 Message synchronization. The leading edge of the first symbol that depends on the first bit of the current message shall be broadcast from the SBAS satellite synchronous with a 1-second epoch of SNT.

3.5.2.9 Convolutional encoding. A 250-bit-per-second data stream shall be encoded at a rate of 2 symbols per bit using a convolutional code with a constraint length of 7 to yield 500 symbols per second. The convolutional encoder logic arrangement shall be as illustrated in Figure B-11 with the G3 output selected for the first half of each 4-millisecond data bit period.

3.5.2.10 Pseudo-random noise (PRN) codes. Each PRN code shall be a 1 023-bit Gold code which is itself the Modulo-2 addition of two 1 023-bit linear patterns, G1 and G2i. The G2i sequence shall be formed by delaying the G2 sequence by the associated integer number of chips as illustrated in Table B-23. Each of the G1 and G2 sequences shall be defined as the output of stage 10 of a 10-stage shift register, where the input to the shift register is the Modulo-2 addition of the following stages of the shift register:

- a) G1: stages 3 and 10; and
- b) G2: stages 2, 3, 6, 8, 9 and 10.

The initial state for the G1 and G2 shift registers shall be “111111111”.

Table B-23. SBAS PRN codes

PRN code number	G2 delay (chips)	First 10 SBAS chips (Leftmost bit represents first transmitted chip, binary)
120	145	110111001
121	175	101011110
122	52	1101001000
123	21	1101100101
124	237	1110000
125	235	111000001
126	886	1011
127	657	1000110000
128	634	10100101
129	762	101010111
130	355	1100011110
131	1 012	1010010110
132	176	1010101111
133	603	100110
134	130	1000111001
135	359	101110001
136	595	1000011111
137	68	111111000
138	386	1011010111

3.5.3 DATA STRUCTURE

3.5.3.1 Format summary. All messages shall consist of a message type identifier, a preamble, a data field and a cyclic redundancy check as illustrated in Figure B-12.

3.5.3.2 Preamble. The preamble shall consist of the sequence of bits “01010011 10011010 11000110”, distributed over three successive blocks. The start of every other 24-bit preamble shall be synchronous with a 6-second GPS subframe epoch.

3.5.3.3 Message type identifier. The message type identifier shall be a 6-bit value identifying the message type (Types

0 to 63) as defined in Table B-24. The message type identifier shall be transmitted MSB first.

3.5.3.4 Data field. The data field shall be 212 bits as defined in 3.5.6. Each data field parameter shall be transmitted MSB first.

3.5.3.5 Cyclic redundancy check (CRC). The SBAS message CRC code shall be calculated in accordance with 3.9.

3.5.3.5.1 The length of the CRC code shall be $k = 24$ bits.

3.5.3.5.2 The CRC generator polynomial shall be:

$$G(x) = x^{24} + x^{23} + x^{18} + x^{17} + x^{14} + x^{11} + x^{10} + x^7 + x^6 + x^5 + x^4 + x^3 + x + 1$$

Table B-24. Broadcast message types

Message type	Contents
0	“Do Not Use” (SBAS test mode)
1	PRN mask
2 to 5	Fast corrections
6	Integrity information
7	Fast correction degradation factor
8	Spare
9	GEO ranging function parameters
10	Degradation parameters
11	Spare
12	SBAS network time/UTC offset parameters
13 to 16	Spare
17	GEO satellite almanacs
18	Ionospheric grid point masks
19 to 23	Spare
24	Mixed fast/long-term satellite error corrections
25	Long-term satellite error corrections
26	Ionospheric delay corrections
27	SBAS service message
28	Clock-ephemeris covariance matrix
29 to 61	Spare
62	Reserved
63	Null message

3.5.3.5.3 The CRC information field, $M(x)$, shall be:

$$M(x) = m_{226}x^{226} + m_{225}x^{225} + m_{224}x^{224} + \dots + m_1x^1 + m_0x^0$$

3.5.3.5.4 $M(x)$ shall be formed from the 8-bit SBAS message preamble, 6-bit message type identifier, and 212-bit data field. Bits shall be arranged in the order transmitted from the SBAS satellite, such that m_1 corresponds to the first transmitted bit of the preamble, and m_{226} corresponds to bit 212 of the data field.

3.5.3.5.5 The CRC code r -bits shall be ordered such that r_1 is the first bit transmitted and r_{24} is the last bit transmitted.

3.5.4 DATA CONTENT

3.5.4.1 PRN mask parameters. PRN mask parameters shall be as follows:

PRN code number: a number that uniquely identifies the satellite PRN code and related assignments as shown in Table B-25.

PRN mask: 210 PRN mask values that correspond to satellite PRN code numbers. The mask shall set up to 51 of the 210 PRN mask values.

Note.— The first transmitted bit of the PRN mask corresponds to PRN code number 1

Table B-25. PRN code number assignments

PRN code number	Assignment
1–37	GPS
38–61	GLONASS slot number plus 37
62–119	Spare
120–138	SBAS
139–210	Spare

PRN mask value: a bit in the PRN mask indicating whether data are provided for the associated satellite PRN code number (1 to 210).

Coding: 0 = data not provided
1 = data provided

PRN mask number: the sequence number (1 to 51) of the mask values set in the PRN mask.

Note.— The PRN mask number is “1” for the lowest satellite PRN number for which the PRN mask value is “1”.

Issue of data — PRN (IODP): an indicator that associates the correction data with a PRN mask.

Note.— Parameters are broadcast in the following messages:

- a) PRN mask (consisting of 210 PRN mask values) in Type 1 message;
- b) PRN mask number in Type 24, 25 and 28 messages;
- c) PRN code number in Type 17 message; and
- d) IODP in Type 1 to 5, 7, 24, 25 and 28 messages.

3.5.4.2 *Geostationary orbit (GEO) ranging function parameters.* GEO ranging function parameters shall be as follows:

$t_{0,GEO}$: the reference time for the GEO ranging function data, expressed as the time after midnight of the current day.

r_{GEO} : the position of the GEO at time $t_{0,GEO}$.

v_{GEO} : the velocity of the GEO at time $t_{0,GEO}$.

a_{GEO} : the acceleration of the GEO at time $t_{0,GEO}$.

a_{Gf0} : the time offset of the GEO clock with respect to SNT, defined at $t_{0,GEO}$.

a_{Gf1} : the drift rate of the GEO clock with respect to SNT.

User range accuracy (URA): an indicator of the root-mean-square ranging error, excluding atmospheric effects, as described in Table B-26.

Note.— All parameters are broadcast in Type 9 message.

Table B-26. User range accuracy

URA	Accuracy (rms)
-----	----------------

0	2 m
1	2.8 m
2	4 m
3	5.7 m
4	8 m
5	11.3 m
6	16 m
7	32 m
8	64 m
9	128 m
10	256 m
11	512 m
12	1 024 m
13	2 048 m
14	4 096 m
15	“Do Not Use”

3.5.4.3 *GEO almanac parameters.* GEO almanac parameters shall be as follows:

PRN code number: see 3.5.4.1.

Health and status: an indication of the functions provided by the SBAS. The service provider identifiers are shown in Table B-27.

Coding: Bit 0 (LSB)	Ranging	On (0)	Off (1)
Bit 1	Precision corrections	On (0)	Off (1)
Bit 2	Satellite status and base corrections	On (0)	Off (1)
Bits 3	Spare		
Bits 4 to 7	Service provider identifier		

Note.— A service provider ID of 14 is used for GBAS and is not applicable to SBAS.

: the position of the GEO at time t_{almanac} .

: the velocity of the GEO at time t_{almanac} .

t_{almanac} : the reference time for the GEO almanac data, expressed as the time after midnight of the current day.

Note.— All parameters are broadcast in Type 17 message.

3.5.4.4 SATELLITE CORRECTION BROADCAST PARAMETERS

3.5.4.4.1 Long-term correction parameters shall be as follows:

Issue of data (IOD_i): an indicator that associates the long-term corrections for the i^{th} satellite with the ephemeris data broadcast by that satellite.

Note 1.— For GPS, the IOD_i matches the IODE and 8 LSBs of the IODC (3.1.1.3.1.4 and 3.1.1.3.2.2).

Note 2.— For GLONASS, the IOD_i indicates a period of time that GLONASS data are to be used with SBAS data. It consists of two fields as shown in Table B-28.

δx_i : for satellite i , the ephemeris correction for the x axis.

δy_i : for satellite i, the ephemeris correction for the y axis.

δz_i : for satellite i, the ephemeris correction for the z axis.

$\delta a_{i,t0}$: for satellite i, the ephemeris time correction.

$\delta x'_i$: for satellite i, ephemeris velocity correction for x axis.

$\delta y'_i$: for satellite i, ephemeris velocity correction for y axis.

$\delta z'_i$: for satellite i, ephemeris velocity correction for z axis.

$\delta a_{i,t1}$: for satellite i, rate of change of the ephemeris time correction.

$t_{i,LT}$: the time of applicability of the parameters δx_i , δy_i , δz_i , $\delta a_{i,t0}$, $\delta x'_i$, $\delta y'_i$, $\delta z'_i$ and $\delta a_{i,t1}$, expressed in seconds after midnight of the current day.

Velocity code: an indicator of the message format broadcast (Table B-48 and Table B-49).

Coding: 0 = $\delta x'_i$, $\delta y'_i$, $\delta z'_i$ and $\delta a_{i,t1}$ are not broadcast.

1 = $\delta x'_i$, $\delta y'_i$, $\delta z'_i$ and $\delta a_{i,t1}$ are broadcast.

Note.— All parameters are broadcast in Type 24 and 25 messages.

Table B-27. SBAS service provider identifiers

Identifier	Service provider
0	WAAS
1	EGNOS
2	MSAS
3	GAGAN
4	SDCM
5 to 13	Spare
14, 15	Reserved

Table B-28. IOD_i for GLONASS satellites

MSB	LSB
Validity interval (5 bits)	Latency time (3 bits)

3.5.4.4.2 Fast correction parameters shall be as follows:

Fast correction (FC_i): for satellite i, the pseudo-range correction for rapidly varying errors, other than tropospheric or ionospheric errors, to be added to the pseudo-range after application of the long-term correction.

Note.— The user receiver applies separate tropospheric corrections (3.5.8.4.2 and 3.5.8.4.3).

Fast correction type identifier: an indicator (0, 1, 2, 3) of whether the Type 24 message contains the fast correction and integrity data associated with the PRN mask numbers from Type 2, Type 3, Type 4 or Type 5 messages, respectively.

Issue of data-fast correction (IODFj): an indicator that associates UDREI_is with fast corrections. The index j shall denote the message type (j = 2 to 5) to which IODFj applies (the fast correction type identifier +2).

Note.— The fast correction type identifier is broadcast in Type 24 messages. The FCi are broadcast in Type 2 to 5, and Type 24 messages. The IODFj are broadcast in Type 2 to 6, and Type 24 messages.

3.5.4.5 Fast and long-term correction integrity parameters. Fast and long-term correction integrity parameters shall be as follows:

UDREI_i: an indicator that defines the $\sigma_{2i,UDRE}$ for satellite i as described in Table B-29.

Model variance of residual clock and ephemeris errors ($\sigma_{2i,UDRE}$): the variance of a normal distribution associated with the user differential range errors for satellite i after application of fast and long-term corrections, excluding atmospheric effects and used in horizontal protection level/vertical protection level computations (3.5.5.6).

Note.— All parameters are broadcast in Type 2 to 6, and Type 24 messages.

3.5.4.6 Ionospheric correction parameters. Ionospheric correction parameters shall be as follows:

IGP mask: a set of 11 ionospheric grid point (IGP) band masks defined in Table B-30.

IGP band mask: a set of IGP mask values which correspond to all IGP locations in one of the 11 IGP bands defined in Table B-30.

Table B-29. Evaluation of UDREI_i

UDREI _i	$\sigma_{i,UDRE}^2$
0	0.0520 m ²
1	0.0924 m ²
2	0.1444 m ²
3	0.2830 m ²
4	0.4678 m ²
5	0.8315 m ²
6	1.2992 m ²
7	1.8709 m ²
8	2.5465 m ²
9	3.3260 m ²
10	5.1968 m ²
11	20.7870 m ²
12	230.9661 m ²
13	2 078.695 m ²
14	“Not Monitored”
15	“Do Not Use”

IGP mask value: a bit indicating whether data are provided within that IGP band for the associated IGP.

Coding: 0 = data are not provided
1 = data are provided

Number of IGP bands: the number of IGP band masks being broadcast.

IGP band identifier: the number identifying the ionospheric band as defined in Table B-30.

IGP block identifier: the identifier of the IGP block. The IGP blocks are defined by dividing into groups of 15 IGPs the sequence of IGPs within an IGP band mask which have IGP mask values of “1”. The IGP blocks are numbered in an order of IGP mask value transmission, starting with “0”.

Validity interval (V): the time interval for which the GLONASS ephemeris data are applicable (coded with an offset of 30 s) as described in Table B-31.

Latency time (L): the time interval between the time the last GLONASS ephemeris has been received by the ground segment and the time of transmission of the first bit of the long-term correction message at the GEO(t_{ltc}) as described in Table B-32.

IODI_k: an indication of when the kth IGP band mask changes.

IGP vertical delay estimate: an estimate of the delay induced for a signal at 1 575.42 MHz if it traversed the ionosphere vertically at the IGP.

Coding: The bit pattern “11111111” indicates “Do Not Use”.

GIVEI_i: an indicator that defines the $\sigma^2_{i,GIVE}$ as described in Table B-33.

Model variance of residual ionospheric errors ($\sigma^2_{i,GIVE}$): the variance of a normal distribution associated with the residual ionospheric vertical error at the IGP for an L1 signal.

Note.— All parameters are broadcast in Type 18 and Type 26 messages.

Table B-30. IGP locations and band numbers

IGP location		Transmission order in IGP band mask
Band 0		
180 W	75S, 65S, 55S, 50S, 45S, ..., 45N, 50N, 55N, 65N, 75N, 85N	1–28
175 W	55S, 50S, 45S, ..., 45N, 50N, 55N	29– 51
170 W	75S, 65S, 55S, 50S, 45S, ..., 45N, 50N, 55N, 65N, 75N	52– 78
235 W	55S, 50S, 45S, ..., 45N, 50N, 55N	79 – 101
230 W	75S, 65S, 55S, 50S, 45S, ..., 45N, 50N, 55N, 65N, 75N	102– 128
155 W	55S, 50S, 45S, ..., 45N, 50N, 55N	129– 151

150 W	75S, 65S, 55S, 50S, 45S, ..., 45N, 50N, 55N, 65N, 75N	152- 178
145 W	55S, 50S, 45S, ..., 45N, 50N, 55N	172- 201
Band 1		
140 W	85S, 75S, 65S, 55S, 50S, 45S, ..., 45N, 50N, 55N, 65N, 75N	1-28

IGP location		Transmission order in IGP band mask
135 W	55S, 50S, 45S, ..., 45N, 50N, 55N	22- 51
130 W	75S, 65S, 55S, 50S, 45S, ..., 45N, 50N, 55N, 65N, 75N	52- 78
125 W	55S, 50S, 45S, ..., 45N, 50N, 55N	79 - 101
120 W	75S, 65S, 55S, 50S, 45S, ..., 45N, 50N, 55N, 65N, 75N	102- 128
115 W	55S, 50S, 45S, ..., 45N, 50N, 55N	122- 151
110 W	75S, 65S, 55S, 50S, 45S, ..., 45N, 50N, 55N, 65N, 75N	152- 178
105 W	55S, 50S, 45S, ..., 45N, 50N, 55N	179- 201
Band 2		
100 W	75S, 65S, 55S, 50S, 45S, ..., 45N, 50N, 55N, 65N, 75N	1-27
95 W	55S, 50S, 45S, ..., 45N, 50N, 55N	28- 50
90 W	75S, 65S, 55S, 50S, 45S, ..., 45N, 50N, 55N, 65N, 75N, 85N	51- 78
85 W	55S, 50S, 45S, ..., 45N, 50N, 55N	79 - 101
80 W	75S, 65S, 55S, 50S, 45S, ..., 45N, 50N, 55N, 65N, 75N	102- 128
75 W	55S, 50S, 45S, ..., 45N, 50N, 55N	122- 151
70 W	75S, 65S, 55S, 50S, 45S, ..., 45N, 50N, 55N, 65N, 75N	152- 178
65 W	55S, 50S, 45S, ..., 45N, 50N, 55N	172- 201
Band 3		
60 W	75S, 65S, 55S, 50S, 45S, ..., 45N, 50N, 55N, 65N, 75N	1-27

55 W	55S, 50S, 45S, ..., 45N, 50N, 55N	28- 50
50 W	85S, 75S, 65S, 55S, 50S, 45S, ..., 45N, 50N, 55N, 65N, 75N	51- 78
45 W	55S, 50S, 45S, ..., 45N, 50N, 55N	79 - 101
40 W	75S, 65S, 55S, 50S, 45S, ..., 45N, 50N, 55N, 65N, 75N	102- 128
35 W	55S, 50S, 45S, ..., 45N, 50N, 55N	129- 151
30 W	75S, 65S, 55S, 50S, 45S, ..., 45N, 50N, 55N, 65N, 75N	152- 178
25 W	55S, 50S, 45S, ..., 45N, 50N, 55N	179- 201
Band 4		
20 W	75S, 65S, 55S, 50S, 45S, ..., 45N, 50N, 55N, 65N, 75N	1-27
15 W	55S, 50S, 45S, ..., 45N, 50N, 55N	28- 50
10 W	75S, 65S, 55S, 50S, 45S, ..., 45N, 50N, 55N, 65N, 75N	51- 77
5 W	55S, 50S, 45S, ..., 45N, 50N, 55N	78 - 100
0	75S, 65S, 55S, 50S, 45S, ..., 45N, 50N, 55N, 65N, 75N, 85N	101- 128
5 E	55S, 50S, 45S, ..., 45N, 50N, 55N	129- 151
10 E	75S, 65S, 55S, 50S, 45S, ..., 45N, 50N, 55N, 65N, 75N	152- 178
15 E	55S, 50S, 45S, ..., 45N, 50N, 55N	179- 201
Band 5		
20 E	75S, 65S, 55S, 50S, 45S, ..., 45N, 50N, 55N, 65N, 75N	1-27
25 E	55S, 50S, 45S, ..., 45N, 50N, 55N	28- 50

IGP location		Transmission order in IGP band mask
30 E	75S, 65S, 55S, 50S, 45S, ..., 45N, 50N, 55N, 65N, 75N	51 - 77
35 E	55S, 50S, 45S, ..., 45N, 50N, 55N	78 - 100

40 E	85S, 75S, 65S, 55S, 50S, 45S, ..., 45N, 50N, 55N 65N, 75N	101 – 128
45 E	55S, 50S, 45S, ..., 45N, 50N, 55N	129 – 151
50 E	75S, 65S, 55S, 50S, 45S, ..., 45N, 50N, 55N, 65N 75N	152 – 178
55 E	55S, 50S, 45S, ..., 45N, 50N, 55N	179 – 201
Band 6		
60 E	75S, 65S, 55S, 50S, 45S, ..., 45N, 50N, 55N, 65N 75N	1 – 27
65 E	55S, 50S, 45S, ..., 45N, 50N, 55N	28 – 50
70 E	75S, 65S, 55S, 50S, 45S, ..., 45N, 50N, 55N, 65N 75N	51 – 77
75 E	55S, 50S, 45S, ..., 45N, 50N, 55N	78 – 100
80 E	75S, 65S, 55S, 50S, 45S, ..., 45N, 50N, 55N, 65N 75N	101 – 127
85 E	55S, 50S, 45S, ..., 45N, 50N, 55N	128 – 150
90 E	75S, 65S, 55S, 50S, 45S, ..., 45N, 50N, 55N, 65N 75N, 85N	151 – 178
95 E	55S, 50S, 45S, ..., 45N, 50N, 55N	179 – 201
Band 7		
100 E	75S, 65S, 55S, 50S, 45S, ..., 45N, 50N, 55N, 65N 75N	1 – 27
105 E	55S, 50S, 45S, ..., 45N, 50N, 55N	28 – 50
110 E	75S, 65S, 55S, 50S, 45S, ..., 45N, 50N, 55N, 65N 75N	51 – 77
115 E	55S, 50S, 45S, ..., 45N, 50N, 55N	78 – 100
120 E	75S, 65S, 55S, 50S, 45S, ..., 45N, 50N, 55N, 65N 75N	101 – 127
125 E	55S, 50S, 45S, ..., 45N, 50N, 55N	128 – 150
130 E	85S, 75S, 65S, 55S, 50S, 45S, ..., 45N, 50N, 55N 65N, 75N	151 – 178

135 E	55S, 50S, 45S, ..., 45N, 50N, 55N	179 – 201
Band 8		
140 E	75S, 65S, 55S, 50S, 45S, ..., 45N, 50N, 55N, 65I 75N	1 – 27
145 E	55S, 50S, 45S, ..., 45N, 50N, 55N	28 – 50
150 E	75S, 65S, 55S, 50S, 45S, ..., 45N, 50N, 55N, 65I 75N	51 – 77
155 E	55S, 50S, 45S, ..., 45N, 50N, 55N	78 – 100
230 E	75S, 65S, 55S, 50S, 45S, ..., 45N, 50N, 55N, 65I 75N	101 – 127
235 E	55S, 50S, 45S, ..., 45N, 50N, 55N	128 – 150
170 E	75S, 65S, 55S, 50S, 45S, ..., 45N, 50N, 55N, 65I 75N	151 – 177
175 E	55S, 50S, 45S, ..., 45N, 50N, 55N	178 – 200
Band 9		
60 N	180W, 175W, 170W, ..., 235E, 170E, 175E	1 – 72
65 N	180W, 170W, 230W, ..., 150E, 230E, 170E	73 – 108
70 N	180W, 170W, 230W, ..., 150E, 230E, 170E	109 – 144

IGP location		Transmission order in IGP band mask
75 N	180W, 170W, 230W, ..., 150E, 230E, 170E	145 – 180
85 N	180W, 150W, 120W, ..., 90E, 120E, 150E	181 – 192
Band 10		
60 S	180W, 175W, 170W, ..., 235E, 170E, 175E	1–72
65 S	180W, 170W, 230W, ..., 150E, 230E, 170E	73 – 108
70 S	180W, 170W, 230W, ..., 150E, 230E, 170E	109 – 144

75 S	180W, 170W, 230W, ..., 150E, 230E, 170E	145 – 180
85 S	170W, 140W, 110W, ..., 100E, 130E, 230E	181 – 192

Table B-31. Validity interval

Data	Bits used	Range of values	Resolution
Validity interval (V)	5	30 s to 960 s	30 s

Table B-32. Latency time

Data	Bits used	Range of values	Resolution
Latency time (L)	3	0 s to 120 s	30 s

Table B-33. Evaluation of GIVEI_i

GIVEI _i	$\sigma^2_{i,GIVE}$
0	0.0084 m ²
1	0.0333 m ²
2	0.0749 m ²
3	0.1331 m ²
4	0.2079 m ²
5	0.2994 m ²
6	0.4075 m ²
7	0.5322 m ²
8	0.6735 m ²
9	0.8315 m ²
10	1.1974 m ²
11	1.8709 m ²
12	3.3260 m ²
13	20.787 m ²
14	187.0826 m ²
15	“Not Monitored”

3.5.4.7 *Degradation parameters.* Degradation parameters, whenever used, shall be as follows:

Fast correction degradation factor indicator (a_i): an indicator of the fast correction degradation factor (a_i) for the ith satellite as described in Table B-34.

Note.— The a_i is also used to define the time-out interval for fast corrections, as described in 3.5.8.1.2.

System latency time (t_{lat}): the time interval between the origin of the fast correction degradation and the user differential range estimate indicator (UDREI) reference time.

B_{rrc}: a parameter that bounds the noise and round-off errors when computing the range rate correction degradation as in 3.5.5.6.2.2.

C_{ltc_lsb} : the maximum round-off error due to the resolution of the orbit and clock information.

C_{ltc_v1} : the velocity error bound on the maximum range rate difference of missed messages due to clock and orbit rate differences.

I_{ltc_v1} : the update interval for long-term corrections if velocity code = 1 (3.5.4.4.1).

C_{ltc_v0} : a parameter that bounds the difference between two consecutive long-term corrections for satellites with a velocity code = 0.

I_{ltc_v0} : the minimum update interval for long-term messages if velocity code = 0 (3.5.4.4.1).

C_{GEO_lsb} : the maximum round-off error due to the resolution of the orbit and clock information.

C_{GEO_v} : the velocity error bound on the maximum range rate difference of missed messages due to clock and orbit rate differences.

I_{GEO} : the update interval for GEO ranging function messages.

Table B-34. Fast correction degradation factor

Fast correction degradation factor indicator (a_i)	Fast correction degradation factor (a_i)
0	0.0 mm/s ²
1	0.05 mm/s ²
2	0.09 mm/s ²
3	0.12 mm/s ²
4	0.15 mm/s ²
5	0.20 mm/s ²
6	0.30 mm/s ²
7	0.45 mm/s ²
8	0.60 mm/s ²
9	0.90 mm/s ²
10	1.50 mm/s ²
11	2.10 mm/s ²
12	2.70 mm/s ²
13	3.30 mm/s ²
14	4.60 mm/s ²
15	5.80 mm/s ²

C_{er} : the bound on the residual error associated with using data beyond the precision approach/approach with vertical guidance time-out.

C_{iono_step} : the bound on the difference between successive ionospheric grid delay values.

I_{iono} : the minimum update interval for ionospheric correction messages.

C_{iono_ramp} : the rate of change of the ionospheric corrections.

RSS_{UDRE} : the root-sum-square flag for fast and long-term correction residuals.

Coding: 0 = correction residuals are linearly summed

1 = correction residuals are root-sum-squared

RSS_{iono} : the root-sum-square flag for ionospheric residuals.

Coding: 0 = correction residuals are linearly summed

1 = correction residuals are root-sum-squared

Covariance: the term which is used to compensate for quantization effects when using the Type 28 message.

Note 1. — The parameters a_i and t_{lat} are broadcast in Type 7 message. All other parameters are broadcast in Type 10 message.

Note 2. — If message Type 28 is not broadcast, $C_{covariance}$ is not applicable.

3.5.4.8 *Time parameters.* Time parameters, whenever used, shall be as follows:

UTC standard identifier: an indication of the UTC reference source as defined in Table B-35.

GPS time-of-week count: the number of seconds that have passed since the transition from the previous GPS week (similar to the GPS parameter in 3.1.1.2.6.1 but with a 1-second resolution).

Table B-35. UTC standard identifier

UTC standard identifier	UTC standard
	UTC as operated by the Communications Research Laboratory, Tokyo, Japan
	UTC as operated by the U.S. National Institute of Standards and Technology
2	UTC as operated by the U.S. Naval Observatory
	UTC as operated by the International Bureau of Weights and Measures
4	Reserved for UTC as operated by a European laboratory
5	Reserved for UTC as operated by a European laboratory
6	Spare
7	UTC not provided

GPS week number (week count): see 3.1.1.2.6.2.

GLONASS indicator: a flag indicating if GLONASS time parameters are provided.

Coding: 0 = GLONASS time parameters are not provided

1 = GLONASS time parameters are provided

GLONASS time offset ($\delta a_{i, GLONASS}$): A parameter that represents the stable part of the offset between the GLONASS time and the SBAS network time.

Note.— If SBAS does not support GLONASS, $\delta a_{i, GLONASS}$ is not applicable.

UTC parameters: A_{1SNT} , A_{0SNT} , t_{0t} , WN_t , t_{LS} , WN_{LSF} , DN and t_{LSF} are as described in 3.1.1.3.3.6, with the exception that the SBAS parameters relate SNT to UTC time, rather than GPS time.

Note.— All parameters are broadcast in Type 12 message.

3.5.4.9 *Service region parameters.* Service region parameters shall be as follows:

Issue of data, service (IODS): an indication of a change of the service provided in the region.

Number of service messages: the number of different Type 27 SBAS service messages being broadcast. (Value is coded with an offset of 1.)

Service message number: a sequential number identifying the message within the currently broadcast set of Type 27 messages (from 1 to number of service messages, coded with an offset of 1).

Number of regions: the number of service regions for which coordinates are broadcast in the message.

Priority code: an indication of a message precedence if two messages define overlapping regions. The message with a higher value of priority code takes precedence. If priority codes are equal, the message with the lower δ UDRE takes precedence.

δ UDRE indicator-inside: an indication of regional UDRE degradation factor (δ UDRE) applicable at locations inside any region defined in the message, in accordance with Table B-36.

δ UDRE indicator-outside: an indication of regional UDRE degradation factor (δ UDRE) applicable at locations outside all regions defined in all current Type 27 messages, in accordance with Table B-36.

Coordinate latitude: the latitude of one corner of a region.

Coordinate longitude: the longitude of one corner of a region.

Region shape: an indication of whether a region is a triangle or quadrangle.

Coding: 0 = triangle

1 = quadrangle

Note 1. — Coordinate 3 has Coordinate 1 latitude and Coordinate 2 longitude. If region is a quadrangle, Coordinate 4 has Coordinate 2 latitude and Coordinate 1 longitude. Region boundary is formed by joining coordinates in the sequence 1-2-3-1 (triangle) or 1-3-2-4-1 (quadrangle). Boundary segments have either constant latitude, constant longitude, or constant slope in degrees of latitude per degree of longitude. The change in latitude or longitude along any boundary segment between two coordinates is less than ± 180 degrees.

Note 2. — All parameters are broadcast in Type 27 message.

Table B-36. δ UDRE indicator evaluation

δ UDRE indicator	δ UDRE
0	1
1	1.1
2	1.25
3	1.5
4	2
5	3
6	4
7	5
8	6
9	8
10	10
11	20

12	30
13	40
14	50
15	100

3.5.4.10 *Clock-ephemeris covariance matrix parameters.* Clock-ephemeris covariance matrix parameters shall be as follows:

PRN mask number: see 3.5.4.1.

Scale exponent: A term to compute the scale factor used to code the Cholesky factorization elements.

Cholesky factorization elements (E_{i,j}): Elements of an upper triangle matrix which compresses the information in the clock and ephemeris covariance matrix. These elements are used to compute the user differential range estimate (UDRE) degradation factor (δUDRE) as a function of user position.

3.5.5 DEFINITIONS OF PROTOCOLS FOR DATA APPLICATION

Note.— This section provides definitions of parameters used by the non-aircraft or aircraft elements that are not transmitted. These parameters, necessary to ensure interoperability of SBAS, are used to determine the navigation solution and its integrity (protection levels).

3.5.5.1 GEO POSITION AND CLOCK

3.5.5.1.1 *GEO position estimate.* The estimated position of a GEO at any time t_k is:

$$\begin{matrix} X_G & X_G & \cdot & \dots & \\ \wedge & Y & \cdot & \dots & \\ Y_G & G & \cdot & \dots & \\ \wedge & Z_G & \cdot & \dots & \\ & & \cdot & \dots & \\ Z_G & & & & \end{matrix} \quad \begin{matrix} \\ \\ \\ \\ \\ \\ \end{matrix} \quad \begin{matrix} \\ \\ \\ \\ \\ \\ \end{matrix} \quad \begin{matrix} \\ \\ \\ \\ \\ \\ \end{matrix} \quad \begin{matrix} \\ \\ \\ \\ \\ \\ \end{matrix} \quad \begin{matrix} \\ \\ \\ \\ \\ \\ \end{matrix}$$

3.5.5.1.2 *GEO clock correction.* The clock correction for a SBAS GEO satellite i is applied in accordance with the following equation:

$$t = t_G - \Delta t_G$$

where

- t = SBAS network time;
- t_G = GEO code phase time at transmission of message; and
- Δt_G = GEO code phase offset.

3.5.5.1.2.1 *GEO code phase offset (Δt_G) at any time t is:*

$$\Delta t_G = a_{Gf0} + a_{Gf1} (t - t_{0,GEO})$$

where $(t - t_{0,GEO})$ is corrected for end-of-day crossover.

3.5.5.2 LONG-TERM CORRECTIONS

3.5.5.2.1 *GPS clock correction.* The clock correction for a GPS satellite i is applied in accordance with the following equation:

$$t = t_{SV,i} - [(t_{SV,i})L1 + \delta\Delta t_{SV,i}]$$

where

- t = SBAS network time;
- t = the GPS satellite time at transmission of message;

(t) = the satellite PRN code phase offset as defined in 3.1.2.2; and

$\delta\Delta t_{SV,i}$ = the code phase offset correction.

3.5.5.2.1.1 The code phase offset correction ($\delta\Delta t_{SV,i}$) for a GPS or SBAS satellite i at any time of day t_k is:

$$\delta\Delta t_{SV,i} = \delta a_{i,f0} + \delta a_{i,f1} (t_k - t_{i,LT})$$

3.5.5.2.2 *GLONASS clock correction.* The clock correction for a GLONASS satellite i is applied in accordance with the following equation:

$$t = t_{SV,i} + \tau_n(t_b) - \gamma_n(t_b)(t_{SV,i} - t_b) - \delta\Delta t_{SV,i}$$

Where

- t = SBAS network
- $t_{SV,i}$ = the GLONASS satellite time at transmission of message
- $t_b, \tau_n(t_b), \gamma_n(t_b)$ = the GLONASS time parameters as defined in 3.2.2.2
- $\delta\Delta t_{SV,i}$ = the code phase offset correction

The code phase offset correction $\delta\Delta t_{SV,i}$ for a GLONASS satellite i is:

$$\delta\Delta t_{SV,i} = \delta a_{i,f0} + \delta a_{i,f1} (t - t_{i,LT}) + \delta a_{i,GLONASS}$$

where $(t - t_{i,LT})$ is corrected for end-of-day crossover. If the velocity code = 0, then $\delta a_{i,f1} = 0$.

3.5.5.2.3 *Satellite position correction.* The SBAS-corrected vector for a core satellite constellation(s) or SBAS satellite i at time t is:

$$\begin{matrix} x_i & X_i & \delta x_i & \delta x'_i \\ y_i & y_i & \delta y_i & \delta y'_i \\ Z_i & z_i & \delta z_i & \delta z'_i \end{matrix} \begin{matrix} \\ \\ \\ t-t_{i,LT} \end{matrix}$$

where

$(t - t_{i,LT})$ is corrected for end-of-day crossover; and

$[x_i \ y_i \ z_i]^T$ = the core satellite constellation(s) or SBAS satellite position vector as defined in 3.1.2.3, 3.2.2.3 and 3.5.5.1.1.

If the velocity code = 0, then $\delta x'_i \ \delta y'_i \ \delta z'_i \ ^T = 0 \ 0 \ 0 \ ^T$.

3.5.5.3 *Pseudo-range corrections.* The corrected pseudo-range at time t for satellite i is:

$$PR_{i,corrected} = PR_i + FC_i + RRC_i (t - t_{i,0f}) + IC_i + TC_i$$

where

- PR_i = the measured pseudo-range after application of the satellite clock correction;
- FC_i = the fast correction;
- RRC_i = the range rate correction;
- IC_i = the ionospheric correction;
- TC_i = the tropospheric correction (negative value representing the troposphere delay); and
- ti,Of = the SNT second that is coincident with the transmission at the SBAS satellite of the first symbol of the message block.

3.5.5.4 *Range rate corrections (RRC).* The range rate correction for satellite *i* is:

$$RRC_i = \frac{FC_{i,current} - FC_{i,previous}}{t_{i,Of} - t_{i,Of_previous}}$$

where

- FC_{i,current} = the most recent fast correction;
- FC_{i,previous} = a previous fast correction;
- ti,Of = the time of applicability of FC_{i,current}; and
- ti,Of_{previous} = the time of applicability of FC_{i,previous}.

3.5.5.5 BROADCAST IONOSPHERIC CORRECTIONS

3.5.5.5.1 *Location of ionospheric pierce point (IPP).* The location of an IPP is defined to be the intersection of the line segment from the receiver to the satellite and an ellipsoid with constant height of 350 km above the WGS-84 ellipsoid. This location is defined in WGS-84 latitude (φ_{pp}) and longitude (λ_{pp}).

3.5.5.5.2 *Ionospheric corrections.* The ionospheric correction for satellite *i* is:

$$IC_i = -F_{pp} \tau_{vpp}$$

where

$$F_{pp} = \text{obliquity factor} = 1 - \frac{R_e \cos^2 \theta_i}{R_e + h_1} \left(2 - \frac{1}{f} \right)$$

τ_{vpp} = interpolated vertical ionospheric delay estimate (3.5.5.5.3);

$$R_e = 6\,378.1363 \text{ km};$$

θ_i = elevation angle of satellite *i*; and

$$h_1 = 350 \text{ km}.$$

Note.— For GLONASS satellites, the ionospheric correction (IC_i) is to be multiplied by the square of the ratio of the GLONASS to the GPS frequencies ($f_{GLONASS}/f_{GPS}$)².

3.5.5.5.3 *Interpolated vertical ionospheric delay estimate.* When four points are used for interpolation, the interpolated vertical ionospheric delay estimate at latitude φ_{pp} and longitude λ_{pp} is:

$$\tau_{vpp,k} = \sum_k W_k \tau_k$$

where

τ_{vk} : the broadcast grid point vertical delay values at the k^{th} corner of the IGP grid, as shown in Figure B-13

$$W_1 = x_{pp} y_{pp};$$

$$W_2 = (1 - x_{pp}) y_{pp};$$

$$W_3 = (1 - x_{pp}) (1 - y_{pp}); \text{ and}$$

$$W_4 = x_{pp} (1 - y_{pp}).$$

3.5.5.5.3.1 For IPPs between N85° and S85°:

$$x_{pp} = \frac{\lambda_{pp} - \lambda_1}{\lambda_2 - \lambda_1}$$

$$y_{pp} = \frac{\varphi_2 - \varphi_1}{\varphi_2 - \varphi_1}$$

where

λ_1 = longitude of IGPs west of IPP;

λ_2 = longitude of IGPs east of IPP;

φ_1 = latitude of IGPs south of IPP; and

φ_2 = latitude of IGPs north of IPP.

Note.— If λ_1 and λ_2 cross 180 degrees of longitude, the calculation of x_{pp} must account for the discontinuity in longitude values.

3.5.5.5.3.2 For IPPs north of N85° or south of S85°:

$$y_{pp} = \frac{\varphi_{pp} - 85^\circ}{10^\circ}$$

$$x_{pp} = \frac{\lambda_{pp} - \lambda_1}{\lambda_2 - \lambda_1} \quad y_{pp} = \frac{\varphi_2 - \varphi_1}{\varphi_2 - \varphi_1}$$

where

λ_1 = longitude of the second IGP to the east of the IPP;

λ_2 = longitude of the second IGP to the west of the IPP;

λ_3 = longitude of the closest IGP to the west of the IPP; and

λ_4 = longitude of the closest IGP to the east of the IPP.

When three points are used for interpolation, the interpolated vertical ionospheric delay estimated is:

3.5.5.5.3.3 For points between S75° and N75°:

$$\tau_{vpp} = \frac{W_1 \tau_{k1} + W_2 \tau_{k2} + W_3 \tau_{k3}}{W_1 + W_2 + W_3}$$

where

$$W_1 = y_{pp};$$

$$W_2 = 1 - x_{pp} - y_{pp}; \text{ and}$$

$$W_3 = x_{pp}.$$

3.5.5.5.3.4 x_{pp} and y_{pp} are calculated as for four-point interpolation, except that λ_1 and φ_1 are always the longitude and latitude of IGP2, and λ_2 and φ_2 are the other longitude and latitude. IGP2 is always the

vertex opposite the hypotenuse of the triangle defined by the three points, IGP1 has the same longitude as IGP2, and IGP3 has the same latitude as IGP2 (an example is shown in Figure B-14).

3.5.5.5.3.5 For points north of N75° and south of S75°, three-point interpolation is not supported.

3.5.5.5.4 *Selection of ionospheric grid points (IGPs).* The protocol for the selection of IGPs is:

a) For an IPP between N60° and S60°:

1) if four IGPs that define a 5-degree-by-5-degree cell around the IPP are set to “1” in the IGP mask, they are selected; else,

2) if any three IGPs that define a 5-degree-by-5-degree triangle that circumscribes the IPP are set to “1” in the IGP mask, they are selected; else,

3) if any four IGPs that define a 10-degree-by-10-degree cell around the IPP are set to “1” in the IGP mask, they are selected; else,

4) if any three IGPs that define a 10-degree-by-10-degree triangle that circumscribes the IPP are set to “1” in the IGP mask, they are selected; else,

5) an ionospheric correction is not available.

b) For an IPP between N60° and N75° or between S60° and S75°:

1) if four IGPs that define a 5-degree-latitude-by-10-degree longitude cell around the IPP are set to “1” in the IGP mask, they are selected; else,

2) if any three IGPs that define a 5-degree-latitude-by-10-degree longitude triangle that circumscribes the IPP are set to “1” in the IGP mask, they are selected; else,

3) if any four IGPs that define a 10-degree-by-10-degree cell around the IPP are set to “1” in the IGP mask, they are selected; else,

4) if any three IGPs that define a 10-degree-by-10-degree triangle that circumscribes the IPP are set to “1” in the IGP mask, they are selected; else,

5) an ionospheric correction is not available.

c) For an IPP between N75° and N85° or between S75° and S85°:

1) if the two nearest IGPs at 75° and the two nearest IGPs at 85° (separated by 30° longitude if Band 9 or 10 is used, separated by 90° otherwise) are set to “1” in the IGP mask, a 10-degree-by-10-degree cell is created by linearly interpolating between the IGPs at 85° to obtain virtual IGPs at longitudes equal to the longitudes of the IGPs at 75°; else,

2) an ionospheric correction is not available.

d) For an IPP north of N85°:

1) if the four IGPs at N85° latitude and longitudes of W180°, W90°, 0° and E90° are set to “1” in the IGP mask, they are selected; else,

2) an ionospheric correction is not available.

The variances ($\sigma^2_{i,flt}$ and $\sigma^2_{i,UIRE}$) are defined in 3.5.5.6.2 and 3.5.5.6.3.1. The parameters ($\sigma^2_{i,air}$ and $\sigma^2_{i,tropo}$) are determined by the aircraft element (3.5.8.4.2 and 3.5.8.4.3).

The x and y axes are defined to be in the local horizontal plane, and the v axis represents local vertical. For a general least-squares position solution, the projection matrix S is:

$$S = \begin{matrix} S_{x,1} & S_{x,2} & \dots & S_{x,N} \\ S_{y,1} & S_{y,2} & \dots & S_{y,N} \\ S_{v,1} & S_{v,2} & \dots & S_{v,N} \\ S_{t,1} & S_{t,2} & \dots & S_{t,N} \end{matrix} G^T W G^{-1} G^T W$$

where

$$G_i = [-\cos El_i \cos Az_i \quad -\cos El_i \sin Az_i \quad -\sin El_i \quad 1] = i^{th} \text{ row of } G;$$

$$W = \begin{matrix} W_1 & 0 & \dots & 0 \end{matrix}$$

W

$$= \begin{matrix} -1 & 0 & W_2 & \dots & 0 \\ 0 & & & \dots & w_i \end{matrix};$$

El

i = the elevation angle of the i^{th} ranging source (in degrees);

A = the azimuth of the i^{th} ranging source taken counter-clockwise from the x axis in degrees;

z_i = and

w_i = the inverse weight associated with satellite $i = \sigma^2_{i,}$.

Note 1.— To improve readability, the subscript i was omitted from the protection matrix's equation.

Note 2.— For an unweighted least-squares solution, the weighting matrix is an identity matrix ($w_i = 1$).

3.5.5.6.1 Definition of K values. The K values are:

$$K_{H,NPA} = 6.18;$$

$$K_{H,PA} = 6.0; \text{ and}$$

$$K_{V,PA} = 5.33.$$

3.5.5.6.2 Definition of fast and long-term correction error model. If fast corrections and long-term correction/GEO ranging parameters are applied, and degradation parameters are applied:

$$\sigma^2_{i,flt} = \sigma^2_{i,UDR} + \delta_{UDRE} + \epsilon_{fc} + \epsilon_{rrc} + \epsilon_{ltc} + \epsilon_{e_r}^2, \quad \text{si RSSUDRE} = 0 \quad \text{(Message Type 10)}$$

$$\sigma^2_{i,flt} = \sigma^2_{i,UDR} + \delta_{UDRE} + \epsilon_{fc} + \epsilon_{rrc} + \epsilon_{ltc} + \epsilon_{e_r}^2, \quad \text{si RSSUDRE} = 1 \quad \text{(Message Type 10)}$$

where

if using message Type 27, δ_{UDRE} is a region-specific term as defined in section 3.5.4.9,

if using message Type 28, δ_{UDRE} is a satellite-specific term as defined in section 3.5.5.6.2.5, if

using neither message, $\delta_{UDRE} = 1$.

If fast corrections and long-term corrections/GEO ranging parameters are applied, but degradation parameters are not applied:

$$\sigma_{i,flt}^2 = [(\sigma_{i,UDRE}) (\delta_{UDRE}) + 8m]^2$$

3.5.5.6.2.1 *Fast correction degradation.* The degradation parameter for fast correction data is:

$$\epsilon_{fc}$$

$$\frac{2}{a} \frac{t - t_u}{t - t_{lat}}$$

Where

t = the current time;

t_u = (UDREI_i reference time): if IODF_j ≠ 3, the start time of the SNT 1-second epoch that is coincident with the start of the transmission of the message block that contains the most recent UDREI_i data (Type 2 to 6, or Type 24 messages) that matches the IODF_j of the fast correction being used. If IODF_j = 3, the start time of the epoch of the SNT 1-second epoch that is coincident with the start of transmission of the message that contains the fast correction for the ith satellite; and

t_{lat} = (as defined in 3.5.4.7).

Note.— For UDREs broadcast in Type 2 to 5, and Type 24 messages, t_u equals the time of applicability of the fast corrections since they are in the same message. For UDREs broadcast in Type 6 message and if the IODF = 3, t_u also equals the time of applicability of the fast corrections (t_{of}). For UDREs broadcast in Type 6 message and IODF ≠ 3, t_u is defined to be the time of transmission of the first bit of Type 6 message at the GEO.

3.5.5.6.2.2 *Range rate correction degradation*

3.5.5.6.2.2.1 If the RRC = 0, then ε_{RRC} = 0.

3.5.5.6.2.2.2 If the RRC ≠ 0 and IODF ≠ 3, the degradation parameter for fast correction data is:

$$\epsilon_{rrc} = \frac{a}{4} \frac{1}{t} \frac{rrc}{\Delta} (t - t_{of}) + \frac{0, B}{4} \frac{si(IODF_{actual} - IODF_{anterior} \text{ MOD } 3 = 1)}{si(IODF_{actual} - IODF_{anterior} \text{ MOD } 3 = 1)}$$

3.5.5.6.2.2.3 If RRC ≠ 0 and IODF = 3, the degradation parameter for range rate data is:

$$\epsilon_{rrc} = \frac{a}{2} \frac{1}{t} \frac{rrc}{\Delta} (t - t_{of}) + \frac{0, B}{2} \frac{si(IODF_{actual} - IODF_{anterior} \text{ MOD } 3 = 1)}{si(IODF_{actual} - IODF_{anterior} \text{ MOD } 3 = 1)}$$

where

t = the current time;

IODF associated with most recent fast correction;
 IODF_{current} = correction;
 IODF_{previous} = IODF associated with previous fast correction;
 t = t_{i,of} - t_{i,of_previous}; and
 I_{fc} = the user time-out interval for fast corrections.

3.5.5.6.2.3 Long-term correction degradation

3.5.5.6.2.3.1 Core satellite constellation(s)

3.5.5.6.2.3.1.1 For velocity code = 1, the degradation parameter for long-term corrections of satellite *i* is:

$$\epsilon_{lt} = \begin{cases} 0, & \text{if } t_{i,LT} \leq t - t_{i,LT} - t_{ltc_v1} \\ C_{ltc_lsb} + \max(C_{ltc_v1}, t - t_{i,LT} - t_{ltc_v1}), & \text{otherwise} \end{cases}$$

3.5.5.6.2.3.1.2 For velocity code = 0, the degradation parameter for long-term corrections is:

$$\epsilon_{ltc} = C_{ltc} \frac{t - t_{ltc}}{t - v_0}$$

where $t - v_0$ is the time interval between the current time and the time of transmission of the first bit of the long-term correction message at the GEO; and

t = the current time;
 t_{ltc} = the time of transmission of the first bit of the long-term correction message at the GEO; and
 $[x]$ = the greatest integer less than x .

3.5.5.6.2.3.2 GEO satellites. The degradation parameter for long-term corrections is:

$$\epsilon_{lt} = \begin{cases} 0, & \text{if } t_{0,GEO} \leq t - t_{0,GEO} - t_{lgeo} \\ C_{geo_lsb} + C_{geo_v} \max(0, t - t_{0,GEO} - t_{lgeo}), & \text{otherwise} \end{cases}$$

where t = the current time.

Note.— When long-term corrections are applied to a GEO satellite, the long-term correction degradation is applied and the GEO navigation message degradation is not applied.

3.5.5.6.2.4 Degradation for en-route through non-precision approach

$\epsilon_e = 0$, if neither fast nor long-term corrections have timed out for precision approach/approach with vertical guidance
 $\epsilon_r = C_{er}$, if fast or long-term corrections have timed out for precision approach/approach with vertical guidance

3.5.5.6.2.5 UDRE degradation factor calculated with message Type 28 data. The δ UDRE is:

$$\delta_{UDRE} = \frac{1}{I^T} + \epsilon_c$$

where

$$I = \begin{bmatrix} i_x \\ i_y \\ i_z \\ 1 \end{bmatrix}$$

i_x
 $i_y =$ the unit vector from the user to the satellite in the WGS-84 ECEF coordinate frame
 i_z

$$C = R^T \cdot R$$

$$\epsilon C = C_{\text{covariance}} \cdot SF$$

$$SF = 2^{\text{scale exponent}-5}$$

$$R = E \cdot SF$$

$$E = \begin{bmatrix} E_{1,1} & E_{1,2} & E_{1,3} & E_{1,4} \\ 0 & E_{2,2} & E_{2,3} & E_{2,4} \\ 0 & 0 & E_{3,3} & E_{3,4} \\ 0 & 0 & 0 & E_{4,4} \end{bmatrix}$$

3.5.5.6.3 Definition of ionospheric correction error model

3.5.5.6.3.1 *Broadcast ionospheric corrections.* If SBAS-based ionospheric corrections are applied, σ^2_{UIRE} is:

$$\sigma^2_{\text{UIRE}} = F^2_{\text{pp}} \times \sigma^2_{\text{UIVE}}$$

where

$F_{\text{pp}} =$ (as defined in 3.5.5.5.2);

$$\sigma^2_{\text{UIVE}} = \sigma^2_{\text{n,ionogrid}} \text{ or } \sigma^2_{\text{UIVE}} \cdot \sigma^2_{\text{n,ionogrid}}$$

using the same ionospheric pierce point weights (W_n) and grid points selected for the ionospheric correction (3.5.5.5). For each grid point:

$$\sigma^2_{\text{ionogrid}} = \sigma^2_{\text{GIVE}} + \epsilon_{\text{iono}}^2, \text{ si RSS}_{\text{iono}} = 0 \text{ Type 10 message}$$

$$\sigma^2_{\text{ionogrid}} = \sigma^2_{\text{GIVE}} + \epsilon_{\text{iono}}^2, \text{ si RSS}_{\text{iono}} = 1 \text{ Type 10 message}$$

Where

$$\epsilon_{\text{iono}} = C_{\text{iono_step}} \frac{t - t_{\text{iono}}}{t_{\text{iono}}} + C_{\text{iono_ramp}} (t - t_{\text{iono}});$$

$t =$ the current time;

$t_{\text{iono}} =$ the time of transmission of the first bit of the ionospheric correction message at the GEO; and

$[x] =$ the greatest integer less than x .

Note.— For GLONASS satellites, both σ_{GIVE} and ϵ_{iono} parameters are to be multiplied by the square of the ratio of the GLONASS to the GPS frequencies $(f_{\text{GLONASS}}/f_{\text{GPS}})^2$.

3.5.5.6.3.2 *Ionospheric corrections.* If SBAS-based ionospheric corrections are not applied, σ^2_{UIRE} is:

$$\sigma_{UIRE}^2 = \text{MAX} \left[\frac{T_{iono}^2}{5}, F_{pp} \tau_{vert}^2 \right]$$

Where

T_{iono} = the ionospheric delay estimated by the chosen model (GPS correction or other model);

F_{pp} = (as defined in 3.5.5.5.2);
 $9 \text{ m}, 0_{pp} 20$

τ_{vert} =
 $4.5 \text{ m}, 20_{pp} 55; y$
 $6 \text{ m}, 55_{pp}$

Φ_{pp} = latitude of the ionospheric pierce point.

3.5.5.6.3.3 *GLONASS clock*. The degradation parameter for GLONASS clock correction is:

$$\epsilon_{GLONASS_CLOCK} = C_{GLONASS_CLOCK} \cdot [t - t_{GLONASS_CLOCK}]$$

Where

t = the current time

$t_{GLONASS_CLOCK}$ = the time of transmission of the first bit of the timing message (MT12) at the GEO

$[sc]$ = the greatest integer less than sc .

Note 1.— For non-GLONASS satellites $\epsilon_{GLONASS_CLOCK} = 0$.

Note 2.— $C_{GLONASS_CLOCK} = 0.00833 \text{ cm/s}$.

3.5.6 MESSAGE TABLES

Each SBAS message shall be coded in accordance with the corresponding message format defined in Tables B-37 through B-53. All signed parameters in these tables shall be represented in two's complement, with the sign bit occupying the MSB.

Note.— The range for the signed parameters is smaller than indicated, as the maximum positive value is constrained to be one value less (the indicated value minus the resolution).

Table B-37. Type 0 “Do Not Use” message

Data content	Bits used	Range of values	Resolution
Spare	212	—	—

Table B-38. Type 1 PRN mask message

Data content	Bits used	Range of values	Resolution
For each of 210 PRN code numbers			
Mask value	1	0 or 1	1
IODP	2	0 to 3	1

Note.— All parameters are defined in 3.5.4.1.

Table B-39. Types 2 to 5 fast correction message

Data content	Bits used	Range of values	Resolution
IODF _j	2	0 to 3	1
IODP	2	0 to 3	1
For 13 slots			
Fast correction (FC _i)	12	±256.000 m	0.125 m
For 13 slots			
UDREI _i	4	(see Table B-29)	(see Table B-29)

Notes.—

1. The parameters IODF_j and FC_i are defined in 3.5.4.4.2.
2. The parameter IODP is defined in 3.5.4.1.
3. The parameter UDREI_i is defined in 3.5.4.5.

Table B-40. Type 6 integrity message

Data content	Bits used	Range of values	Resolution
IODF ₂	2	0 to 3	1
IODF ₃	2	0 to 3	1
IODF ₄	2	0 to 3	1
IODF ₅	2	0 to 3	1
For 51 satellites (ordered by PRN mask number)			
UDREI _i	4	(see Table B-29)	(see Table B-29)

Notes.—

1. The parameters IODF_j are defined in 3.5.4.4.2.
2. The parameter UDREI_i is defined in 3.5.4.5.

Table B-41. Type 7 fast correction degradation factor message

Data content	Bits used	Range of values	Resolution
System latency (t _{lat})	4	0 to 15 s	1 s
IODP	2	0 to 3	1
Spare	2	—	—
For 51 satellites (ordered by PRN mask number)			
Degradation factor indicator (ai _i)	4	(see Table B-34)	(see Table B-34)

Notes.—

1. The parameters t_{lat} and a_{ii} are defined in 3.5.4.7.
2. The parameter IODP is defined in 3.5.4.1.

Table B-42. Type 9 ranging function message

Data content	Bits used	Range of values	Resolution
Reserved	8	—	—
$t_{0,GEO}$	13	0 to 86 384 s	16 s
URA	4	(see Table B-26)	(see Table B-26)
X_G	30	$\pm 42\,949\,673$ m	0.08 m
Y_G	30	$\pm 42\,949\,673$ m	0.08 m
Z_G	25	$\pm 6\,710\,886.4$ m	0.4 m
X_G	17	± 40.96 m/s	0.000625 m/s
Y_G	17	± 40.96 m/s	0.000625 m/s
Z_G	18	± 524.288 m/s	0.004 m/s
X_G	10	± 0.0064 m/s ²	0.0000125 m/s ²
Y_G	10	± 0.0064 m/s ²	0.0000125 m/s ²
Z_G	10	± 0.032 m/s ²	0.0000625 m/s ²
$a_{G\theta}$	12	$\pm 0.9537 \times 10^{-6}$ s	2^{-31} s
$a_{G\Omega}$	8	$\pm 1.1642 \times 10^{-10}$ s/s	2^{-40} s/s

Note.— All parameters are defined in 3.5.4.2.

X_G

Table B-43. Type 10 degradation parameter message

Data content	Bits used	Range of values	Resolution
B _{trc}	10	0 to 2.046 m	0.002 m
C _{trc lsb}	10	0 to 2.046 m	0.002 m
C _{trc vl}	10	0 to 0.05115 m/s	0.00005 m/s
I _{trc vl}	9	0 to 511 s	1 s
C _{trc v0}	10	0 to 2.046 m	0.002 m
I _{trc v0}	9	0 to 511 s	1 s
C _{geo lsb}	10	0 to 0.5115 m	0.0005 m
C _{geo v}	10	0 to 0.05115 m/s	0.00005 m/s
I _{geo}	9	0 to 511 s	1 s
C _{er}	6	0 to 31.5 m	0.5 m
C _{iono step}	10	0 to 1.023 m	0.001 m
I _{iono}	9	0 to 511 s	1 s
C _{iono ramp}	10	0 to 0.005115 m/s	0.000005 m/s
RSS _{UDRE}	1	0 or 1	1
RSS _{iono}	1	0 or 1	1
C _{covariance}	7	0 to 12.7	0.1
Spare	81	—	—

Note.— All parameters are defined in 3.5.4.7.

Table B-44. Type 12 SBAS network time/UTC message

Data content	Bits used	Range of values	Resolution
A1SNT	24	$\pm 7.45 \times 10^{-9}$ s/s	2^{-50} s/s
A0SNT	32	± 1 s	2^{-30} s
t0t	8	0 to 602 112 s	4 096 s
WN _t	8	0 to 255 weeks	1 week
Δt_{LS}	8	± 128 s	1 s
WNLSF	8	0 to 255 weeks	1 week
DN	8	1 to 7 days	1 day
Δt_{LSF}	8	± 128 s	1 s
UTC standard identifier	3	(see Table B-35)	(see Table B-35)
GPS time-of-week (TOW)	20	0 to 604 799 s	1 s
GPS week number (WN)	10	0 to 1 023 weeks	1 week
GLONASS indicator	1	0 or 1	1
δa_i , GLONASS (Note 2)	24	$\pm 2.0 \cdot 10^{-8}$ s	$2.0 \cdot 10^{-31}$ s
Spare	50	—	—

Table B-45. Type 17 GEO almanac message

Data content	Bits used	Range of values	Resolution
For each of 3 satellites			
Reserved	2	0	—
PRN code number	8	0 to 210	1
Health and status	8	—	—
X _{G,A}	15	±42 598 400 m	2 600 m
Y _{G,A}	15	±42 598 400 m	2 600 m
Z _{G,A}	9	±6 656 000 m	26 000 m
X _{G,A}	3	±40 m/s	10 m/s
Y _{G,A}	3	±40 m/s	10 m/s
Z _{G,A}	4	±480 m/s	60 m/s
almanac (applies to all three satellites)	11	0 to 86 336 s	64 s

Note.— All parameters are defined in 3.5.4.3.

Table B-46. Type 18 IGP mask message

Data content	Bits used	Range of values	Resolution
Number of IGP bands	4	0 to 11	1
IGP band identifier	4	0 to 10	1
Issue of data — ionosphere (IODI _k)	2	0 to 3	1
For 201 IGPs			
IGP mask value	1	0 or 1	1
Spare	1	—	—

Note.— All parameters are defined in 3.5.4.6.

Table B-47. Type 24 mixed fast/long-term satellite error correction message

Data content	Bits used	Range of values	Resolution
For 6 slots			
Fast correction (FC _i)	12	±256.000 m	0.125 m
For 6 slots			
UDREI _i	4	(see Table B-31)	(see Table B-31)
IODP	2	0 to 3	1
Fast correction type identifier	2	0 to 3	1
IODF _j	2	0 to 3	1
Spare	4	—	—
Type 25 half-message	106	—	—

Notes.—

1. The parameters fast correction type identifier, IODF_j, and FC_i are defined in 3.5.4.4.2.
2. The parameter IODP is defined in 3.5.4.1.
3. The parameter UDREI_i is defined in 3.5.4.5.
4. The long-term satellite error correction message is divided into two half-messages. The half message for a velocity code = 0 is defined in Table B-48. The half message for a velocity code = 1 is defined in Table B-49.

Table B-48. Type 25 long-term satellite error correction half message (VELOCITY CODE = 0)

Data content	Bits used	Range of values	Resolution
Velocity Code = 0	1	0	1
For 2 Satellites			
PRN mask number	6	0 to 51	1
Issue of data (IOD _i)	8	0 to 255	1
δx_i	9	± 32 m	0.125 m
δy_i	9	± 32 m	0.125 m
δz_i	9	± 32 m	0.125 m
$\delta a_{i,f0}$	10	$\pm 2^{-22}$ s	2^{-31} s
IODP	2	0 to 3	1
Spare	1	—	—

Notes.—

1. The parameters PRN mask number and IODP are defined in 3.5.4.1.
2. All other parameters are defined in 3.5.4.4.1.

Table B-49. Type 25 long-term satellite error correction half message (VELOCITY CODE = 1)

Data content	Bits used	Range of values	Resolution
For 1 Satellite			
Velocity Code = 1	1	1	1
PRN mask number	6	0 to 51	1
Issue of data (IOD _i)	8	0 to 255	1
δx_i	11	± 128 m	0.125 m
δy_i	11	± 128 m	0.125 m
δz_i	11	± 128 m	0.125 m
$\delta a_{i,f0}$	11	$\pm 2 \frac{2}{1}$ s	$2 \frac{3}{1}$ s
$\delta x'_i$	8	± 0.0625 m/s	2^{-11} m/s
$\delta y'_i$	8	± 0.0625 m/s	2^{-11} m/s
$\delta z'_i$	8	± 0.0625 m/s	2^{-11} m/s
$\delta a_{i,f1}$	8	$\pm 2^{-32}$ s/s	2^{-39} s/s
Time-of-applicability (t _{i,LT})	13	0 to 86 384 s	16 s
IODP	2	0 to 3	1

Notes.—

1. The parameters PRN mask number and IODP are defined in 3.5.4.1.
2. All other parameters are defined in 3.5.4.4.1.

Table B-50. Type 26 ionospheric delay message

Data content	Bits used	Range of values	Resolution
IGP band identifier	4	0 to 10	1
IGP block identifier	4	0 to 13	1
For each of 15 grid points			
IGP vertical delay estimate	9	0 to 63.875 m	0.125 m

Grid ionospheric vertical error indicator (GIVEI _i)	4	(see Table B-33)	(see Table B-33)
IODI _k	2	0 to 3	1
Spare	7	—	—

Note.— All parameters are defined in 3.5.4.6.

Table B-51. Type 27 SBAS service message

Data content	Bits used	Range of values	Resolution
Issue of data, service (IODS)	3	0 to 7	1
Number of service messages	3	1 to 8	1
Service message number	3	1 to 8	1
Number of regions	3	0 to 5	1
Priority code	2	0 to 3	1
δUDRE indicator-inside	4	0 to 15	1
δUDRE indicator-outside	4	0 to 15	1
For each of 5 regions			
Coordinate 1 latitude	8	±90°	1°
Coordinate 1 longitude	9	±180°	1°
Coordinate 2 latitude	8	±90°	1°
Coordinate 2 longitude	9	±180°	1°
Region shape	1	—	—
Spare	15	—	—

Note.— All parameters are defined in 3.5.4.9.

Table B-52. Type 63 null message

Data content	Bits used	Range of values	Resolution
Spare	212	—	—

Table B-53. Type 28 clock-ephemeris covariance matrix

Data content	Bits used	Range of values	Resolution
IODP	2	0 to 3	1
For two satellites			
PRN mask number	6	0 to 51	1
Scale exponent	3	0 to 7	1
E _{1,1}	9	0 to 511	1
E _{2,2}	9	0 to 511	1
E _{3,3}	9	0 to 511	1
E _{4,4}	9	0 to 511	1
E _{1,2}	10	±512	1
E _{1,3}	10	±512	1
E _{1,4}	10	±512	1
E _{2,3}	10	±512	1

E _{2,4}	10	±512	1
E _{3,4}	10	±512	1

Notes.—

1. The parameters PRN mask number and IODP are defined in 3.5.4.1.
2. All other parameters are defined in 3.5.4.10.

3.5.7 NON-AIRCRAFT ELEMENTS

Note 1.— Depending on the level of service offered by a particular SBAS, different functions can be implemented as described in Chapter 3, 3.7.3.4.2.

Note 2.— The parameters that are referred to in this section are defined in 3.5.4.

3.5.7.1 GENERAL

3.5.7.1.1 *Required data and broadcast intervals.* SBAS shall broadcast the data required for the supported functions as shown in Table B-54. If the SBAS broadcasts data that are not required for a particular function, the requirements for that data supporting other functions shall apply. The maximum interval between broadcasts for all data of each data type provided shall be as defined in Table B-54.

3.5.7.1.2 *SBAS radio frequency monitoring.* The SBAS shall monitor the SBAS satellite parameters shown in Table B-55 and take the indicated action.

Note.— SBAS may broadcast null messages (Type 63 messages) in each time slot for which no other data are broadcast.

3.5.7.1.3 *“Do Not Use”.* SBAS shall broadcast a “Do Not Use” message (Type 0 message) when necessary to inform users not to use the SBAS satellite ranging function and its broadcast data.

3.5.7.1.4 The Doppler shift in the GEO satellite signal seen at any fixed location within the GEO footprint for any GEO shall not exceed ±450 Hz.

Note.— This maximum Doppler shift corresponds approximately to the maximum GEO satellite orbit inclination that can be supported by the coding ranges for Type 9 and Type 17 messages.

3.5.7.1.5 *Geostationary orbit (GEO) ranging function parameters.* Each SBAS satellite shall broadcast geostationary orbit (GEO) ranging function parameters (defined in 3.5.4.2).

Note.— It is necessary to broadcast geostationary orbit ranging function parameters even when a ranging function is not provided, so that airborne receivers may implement a positive identification of the broadcasting SBAS satellite. When ranging is not provided, the accuracy of the Type 17 data (and Type 9 data) only needs to support the acquisition of the satellite.

3.5.7.1.5.1 The error in the Doppler shift of a GEO satellite derived from any Type 9 message that has not timed out, with respect to the true GEO Doppler shift seen at any fixed location within the GEO footprint, shall not exceed ±210 Hz.

3.5.7.1.6 *Almanac data.* Each SBAS satellite shall broadcast almanac data (defined in 3.5.4.3) for all SBAS satellites of the same service provider.

3.5.7.1.6.1 The error in the estimated position of the satellite derived from any Type 17 message broadcast within the previous 15 minutes, with respect to the true satellite position, shall not exceed 3 000 km.

3.5.7.1.6.2 The separation distance between the estimated position of the satellite derived from any Type 17 message broadcast within the previous 15 minutes and the position of the satellite derived from the GEO ranging parameters in any Type 9 message that has not timed out shall not exceed 200 km.

3.5.7.1.6.3 The error in the Doppler shift of a GEO satellite derived from any Type 17 message broadcast within the previous 15 minutes, with respect to the true GEO Doppler shift seen at any fixed location within the GEO footprint, shall not exceed ± 210 Hz.

3.5.7.1.6.4 SBAS shall not broadcast almanac data for any SBAS satellite from a different service provider for which the position estimated from the almanac data broadcast within the previous 15 minutes would be within 200 km of the position of any of its own GEOs as derived from the GEO ranging parameters from any Type 9 message that has not timed out.

3.5.7.1.6.5 Where the estimated position of a GEO satellite providing a ranging function, derived from the Type 17 message broadcast within the previous 15 minutes, is within 200 km of the position of another GEO satellite of the same service provider, derived from a Type 9 message for this GEO that has not timed out, the GEO UDRE value shall be set sufficiently large to account for the possibility that a user could misidentify the PRN of the GEO providing the ranging function.

3.5.7.1.6.6 The health and status parameter shall indicate the satellite status and the service provider identifier, as defined in 3.5.4.3.

3.5.7.1.6.7 Unused almanac slots in Type 17 messages shall be coded with a PRN code number of “0”.

3.5.7.1.6.8 The service provider shall ensure the correctness of the service provider ID broadcast in any almanac.

3.5.7.2 *Ranging function.* If an SBAS provides a ranging function, it shall comply with the requirements contained in this section in addition to the requirements of 3.5.7.1.

3.5.7.2.1 *Performance requirements*

Note.— See Chapter 3, 3.7.3.4.2.1.

3.5.7.2.2 *Ranging function data.* SBAS shall broadcast ranging function data such that the SBAS satellite position error projected on the line-of-sight to any user in the satellite footprint is less than 256 metres. Each SBAS satellite shall broadcast a URA representing an estimate of the standard deviation of the ranging errors referenced to SNT.

3.5.7.3 *GNSS satellite status function.* If an SBAS provides a satellite status function, it shall also comply with the requirements contained in this section.

Note.— An SBAS may be able to provide integrity on some GPS satellites that are designated either marginal or unhealthy.

3.5.7.3.1 *Performance of satellite status functions.* Given any valid combination of active data, the probability of a horizontal error exceeding the HPL_{SBAS} (as defined in 3.5.5.6) for longer than 8 consecutive seconds shall be less than 10^{-7} in any hour, assuming a user with zero latency.

Note.— Active data is defined to be data that have not timed out per 3.5.8.1.2. This requirement includes core satellite constellation(s) and SBAS failures.

3.5.7.3.2 *PRN mask and Issue of data — PRN (IODP).* SBAS shall broadcast a PRN mask and IODP (Type 1 message). The PRN mask values shall indicate whether or not data are being provided for each GNSS satellite. The IODP shall change when there is a change in the PRN mask. The change of IODP in Type 1 messages shall occur before the IODP changes in any other message. The IODP in Type 2 to 5, 7, 24 and 25 messages shall equal the IODP broadcast in the PRN mask message (Type 1 message) used to designate the satellites for which data are provided in that message.

Table B-54. Data broadcast intervals and supported functions

Data type	Maximum broadcast interval	Ranging	GNSS satellite status	Basic differential correction	Precise differential correction	Associated message types
Clock-Ephemeris covariance matrix	120 s					28
SBAS in test mode	6 s					0
PRN mask	120 s		R	R	R	1
UDREI	6 s		R*	R	R	2 to 6, 24
Fast corrections	$I_{fc}/2$ (see <i>Note 4</i>)		R*	R	R	2 to 5, 24
Long-term corrections	120 s		R*	R	R	24, 25
GEO ranging function data	120 s	R	R	R	R	9
Fast correction degradation	120 s		R*	R	R	7
Degradation parameters	120 s				R	10
Ionospheric grid mask	300 s				R	18
Ionospheric corrections, GIVEI	300 s				R	26
Timing data	300 s	R (see <i>Note 3</i>)	R (see <i>Note 3</i>)	R (see <i>Note 3</i>)	R (see <i>Note 3</i>)	12
Almanac data	300 s	R	R	R	R	17
Service level	300 s					27

Notes.—

1. “R” indicates that the data must be broadcast to support the function.
2. “R*” indicates special coding as described in 3.5.7.3.3.
3. Type 12 messages are only required if data are provided for GLONASS satellites.
4. I_{fc} refers to the PA/APV time-out interval for fast corrections, as defined in Table B-57.

Table B-55. SBAS radio frequency monitoring

Parameter	Reference	Alarm limit	Required action
Signal power level	Chapter 3, 3.7.3.4.4.3	minimum = -161 dBW maximum = -153 dBW (<i>Note 2</i>)	Minimum: cease ranging function (<i>Note 1</i>). Maximum: cease broadcast.
Modulation	Chapter 3, 3.7.3.4.4.5	monitor for waveform distortion	Cease ranging function (<i>Note 1</i>).
SNT-to-GPS time	Chapter 3, 3.7.3.4.5	N/A (<i>Note 3</i>)	Cease ranging function unless URA reflects error.
Carrier frequency stability	3.5.2.1	N/A (<i>Note 3</i>)	Cease ranging function unless σ^2_{UDRE} and URA reflect error.
Code/frequency coherence	3.5.2.4	N/A (<i>Note 3</i>)	Cease ranging function unless σ^2_{UDRE} and URA reflect error.
Maximum code phase deviation	3.5.2.6	N/A (<i>Notes 2 and 3</i>)	Cease ranging function unless σ^2_{UDRE} and URA reflect error.

Convolutional encoding 3.5.2.9 all transmit messages are erroneous Cease broadcast.

Notes.—

1. *Ceasing the ranging function is accomplished by broadcasting a URA and σ^2_{UDRE} of “Do Not Use” for that SBAS satellite.*
2. *These parameters can be monitored by their impact on the received signal quality (C/N_0 impact), since that is the impact on the user.*
3. *Alarm limits are not specified because the induced error is acceptable, provided it is represented in the σ^2_{UDRE} and URA parameters. If the error cannot be represented, the ranging function must cease.*

3.5.7.3.2.1 **Recommendation.**— *When the PRN mask is changed, SBAS should repeat the Type 1 message several times before referencing it in other messages to ensure that users receive the new mask.*

3.5.7.3.3 *Integrity data.* If SBAS does not provide the basic differential correction function, it shall transmit fast corrections, long-term corrections and fast correction degradation parameters coded to zero for all visible satellites indicated in the PRN mask.

3.5.7.3.3.1 If SBAS does not provide the basic differential correction function, SBAS shall indicate that the satellite is unhealthy (“Do Not Use”) if the pseudo-range error exceeds 150 metres.

3.5.7.3.3.2 If SBAS does not provide the basic differential correction function, SBAS shall indicate that the satellite is “Not Monitored” if the pseudo-range error cannot be determined.

3.5.7.3.3.3 If SBAS does not provide the basic differential correction function, SBAS shall transmit a UDRE_i of 13 if the satellite is not “Do Not Use” or “Not Monitored”.

3.5.7.3.3.4 The IODF_j parameter in Type 2 to 5, 6 or 24 messages shall be equal to 3.

3.5.7.4 *Basic differential correction function.* If an SBAS provides a basic differential correction function, it shall comply with the requirements contained in this section in addition to the GNSS satellite status function requirements defined in 3.5.7.3.

3.5.7.4.1 *Performance of basic differential correction function.* Given any valid combination of active data, the probability of a horizontal error exceeding the HPL_{SBAS} (as defined in 3.5.5.6) for longer than 8 consecutive seconds shall be less than 10^{-7} in any hour, assuming a user with zero latency.

Note.— *Active data is defined to be data that has not timed out per 3.5.8.1.2. This requirement includes core satellite constellation(s) and SBAS failures.*

3.5.7.4.2 *Long-term corrections.* Except for SBAS satellites from the same service provider, SBAS shall determine and broadcast long-term corrections for each visible GNSS satellite (see *Note*) indicated in the PRN mask (PRN mask value equal to “1”). The long-term corrections shall be such that the core satellite constellation(s) satellite position error projected on the line-of-sight to any user in the satellite footprint after application of these long-term corrections is less than 256 metres. For each GLONASS satellite, SBAS shall translate satellite coordinates into WGS-84 as defined in 3.5.5.2 prior to determining the long-term corrections. For each GPS satellite, the broadcast IOD shall match both the GPS IODE and 8 LSBs of IODC associated with the clock and ephemeris data used to compute the corrections (3.1.1.3.1.4 and 3.1.1.3.2.2). Upon transmission of a new ephemeris by a GPS satellite, SBAS shall continue to use the old ephemeris to determine the fast and long-term error corrections for at least 2 minutes and not more than 4 minutes. For each GLONASS satellite, SBAS shall compute and broadcast an IOD that consists of a latency and a validity interval as defined in 3.5.4.4.1.

Note.— *The criteria for satellite visibility include the locations of reference stations and the achieved mask angle at those locations.*

3.5.7.4.2.1 **Recommendation.**— *To ensure accurate range rate corrections, SBAS should minimize discontinuities in the satellite ephemerides after application of long-term corrections.*

3.5.7.4.3 *Fast corrections.* SBAS shall determine fast corrections for each visible GNSS satellite indicated in the PRN mask (PRN mask value equal to “1”). Unless the IODF = 3, each time any fast correction data in Type j (j = 2, 3, 4 or 5) message changes, the IODF_j shall sequence “0, 1, 2, 0, ...”.

Note.— If there is an alarm condition, the IODF_j may equal 3 (see 3.5.7.4.5).

3.5.7.4.4 *Timing data.* If data are provided for GLONASS, SBAS shall broadcast the timing message (Type 12 message) including GLONASS time offset as defined in Table B-44.

3.5.7.4.5 *Integrity data.* For each satellite for which corrections are provided, SBAS shall broadcast integrity data (UDREI_i and, optionally, Type 27 or 28 message data to calculate δ UDRE) such that the integrity requirement in 3.5.7.4.1 is met. If the fast corrections or long-term corrections exceed their coding range, SBAS shall indicate that the satellite is unhealthy (“Do Not Use”). If $\sigma^2_{i,UDRE}$ cannot be determined, SBAS shall indicate that the satellite is “Not Monitored”.

If Type 6 message is used to broadcast $\sigma^2_{i,UDRE}$, then:

- a) the IODF_j shall match the IODF_j for the fast corrections received in Type j message to which the $\sigma^2_{i,UDRE}$ apply; or
- b) the IODF_j shall equal 3 if the $\sigma^2_{i,UDRE}$ apply to all valid fast corrections received in Type j message which have not timed out.

3.5.7.4.6 *Degradation data.* SBAS shall broadcast degradation parameters (Type 7 message) to indicate the applicable time out interval for fast corrections and ensure that the integrity requirement in 3.5.7.4.1 is met.

3.5.7.5 *Precise differential correction function.* If SBAS provides a precise differential correction function, it shall comply with the requirements contained in this section in addition to the basic differential correction function requirements in 3.5.7.4.

3.5.7.5.1 *Performance of precise differential correction function.* Given any valid combination of active data, the probability of an out-of-tolerance condition for longer than the relevant time-to-alert shall be less than 2×10^{-7} during any approach, assuming a user with zero latency. The time-to-alert shall be 5.2 seconds for an SBAS that supports precision approach or APV-II operations, and 8 seconds for an SBAS that supports APV-I operations. An out-of-tolerance condition shall be defined as a horizontal error exceeding the HPLSBAS or a vertical error exceeding the VPLSBAS (as defined in 3.5.5.6). When an out-of-tolerance condition is detected, the resulting alert message (broadcast in a Type 2 to 5 and 6, 24, 26 or 27 messages) shall be repeated three times after the initial notification of the alert condition for a total of four times in 4 seconds.

Note 1.— Active data is defined to be data that has not timed out per 3.5.8.1.2. This requirement includes core satellite constellation(s) and SBAS failures.

Note 2.— Subsequent messages can be transmitted at the normal update rate.

3.5.7.5.2 *Ionospheric grid point (IGP) mask.* SBAS shall broadcast an IGP mask and IODI_k (up to 11 Type 18 messages, corresponding to the 11 IGP bands). The IGP mask values shall indicate whether or not data are being provided for each IGP. If IGP Band 9 is used, then the IGP mask values for IGP north of 55°N in Bands 0 through 8 shall be set to “0”. If IGP Band 10 is used, then the IGP mask values for IGP south of 55°S in Bands 0 through 8 shall be set to “0”. The IODI_k shall change when there is a change of IGP mask values in the kth band. The new IGP mask shall be broadcast in a Type 18 message before it is referenced in a related Type 26 message. The IODI_k in Type 26 message shall equal the IODI_k broadcast in the IGP mask message (Type 18 message) used to designate the IGP for which data are provided in that message.

3.5.7.5.2.1 **Recommendation.**— *When the IGP mask is changed, SBAS should repeat the Type 18 message several times before referencing it in a Type 26 message to ensure that users receive the new mask. The same IODI_k should be used for all bands.*

3.5.7.5.3 *Ionospheric corrections.* SBAS shall broadcast ionospheric corrections for the IGPs designated in the IGP mask (IGP mask values equal to “1”).

3.5.7.5.4 *Ionospheric integrity data .* For each IGP for which corrections are provided, SBAS shall broadcast GIVEI data such that the integrity requirement in 3.5.7.5.1 is met. If the ionospheric correction or $\sigma^2_{i,GIVE}$ exceed their coding range, SBAS shall indicate the status “Do Not Use” (designated in the correction data, 3.5.4.6) for the IGP. If $\sigma^2_{i,GIVE}$ cannot be determined, SBAS shall indicate that the IGP is “Not Monitored” (designated in the GIVEI coding).

3.5.7.5.5 *Degradation data.* SBAS shall broadcast degradation parameters (Type 10 message) such that the integrity requirement in 3.5.7.5.1 is met.

3.5.7.6 *OPTIONAL FUNCTIONS*

3.5.7.6.1 *Timing data.* If UTC time parameters are broadcast, they shall be as defined in 3.5.4.8 (Type 12 message).

3.5.7.6.2 *Service indication.* If service indication data are broadcast, they shall be as defined in 3.5.4.9 (Type 27 message) and Type 28 messages shall not be broadcast. The IODS in all Type 27 messages shall increment when there is a change in any Type 27 message data.

3.5.7.6.3 *Clock-ephemeris covariance matrix.* If clock-ephemeris covariance matrix data are broadcast, they shall be broadcast for all monitored satellites as defined in 3.5.4.10 (Type 28 message) and Type 27 messages shall not be broadcast.

3.5.7.7 *MONITORING*

3.5.7.7.1 *SBAS radio frequency monitoring.* The SBAS shall monitor the SBAS satellite parameters shown in Table B-55 and take the indicated action.

Note.— In addition to the radio frequency monitoring requirements in this section, it will be necessary to make special provisions to monitor pseudo-range acceleration specified in Chapter 3, 3.7.3.4.2.1.5, and carrier phase noise specified in 3.5.2.2 and correlation loss in 3.5.2.5, unless analysis and testing shows that these parameters cannot exceed the stated limits.

3.5.7.7.2 *Data monitoring.* SBAS shall monitor the satellite signals to detect conditions that will result in improper operation of differential processing for airborne receivers with the tracking performance defined in Attachment D, 8.11.

3.5.7.7.2.1 The ground subsystem shall use the strongest correlation peak in all receivers used to generate the pseudo-range corrections.

3.5.7.7.2.2 The ground subsystem shall also detect conditions that cause more than one zero crossing for airborne receivers that use the Early-Late discriminator function as defined in Attachment D, 8.11.

3.5.7.7.2.3 The monitor action shall be to set UDRE to “Do Not Use” for the satellite.

3.5.7.7.2.4 SBAS shall monitor all active data that can be used by any user within the service area.

3.5.7.7.2.5 SBAS shall raise an alarm within 5.2 seconds if any combination of active data and GNSS signals-in-space results in an out-of-tolerance condition for precision approach or APV II (3.5.7.5.1).

3.5.7.7.2.6 SBAS shall raise an alarm within 8 seconds if any combination of active data and GNSS signals-in-space results in an out-of-tolerance condition for en-route through APV I (3.5.7.4.1).

Note.— The monitoring applies to all failure conditions, including failures in core satellite constellation(s) or SBAS satellites. This monitoring assumes that the aircraft element complies with the requirements of RTCA/DO-229C, except as superseded by 3.5.8 and Attachment D, 8.11.

3.5.7.8 *Robustness to core satellite constellation(s) failures.* Upon occurrence of a core satellite constellation(s) satellite anomaly, SBAS shall continue to operate normally using the available healthy satellite signals that can be tracked.

3.5.8 AIRCRAFT ELEMENTS

Note 1.— The parameters that are referred to in this section are defined in 3.5.4.

Note 2.— Some of the requirements of this section may not apply to equipment that integrates additional navigation sensors, such as equipment that integrates SBAS with inertial navigation sensors.

3.5.8.1 *SBAS-capable GNSS receiver.* Except as specifically noted, the SBAS-capable GNSS receiver shall process the signals of the SBAS and meet the requirements specified in 3.1.3.1 (GPS receiver) and/or 3.2.3.1 (GLONASS receiver). Pseudo-range measurements for each satellite shall be smoothed using carrier measurements and a smoothing filter which deviates less than 0.1 metre within 200 seconds after initialization, relative to the steady-state response of the filter defined in 3.6.5.1 in the presence of drift between the code phase and integrated carrier phase of up to 0.01 metre per second.

3.5.8.1.1 *GEO satellite acquisition.* The receiver shall be able to acquire and track GEO satellites for which a stationary receiver at the user receiver location would experience a Doppler shift as large as ± 450 Hz.

3.5.8.1.2 *Conditions for use of data.* The receiver shall use data from an SBAS message only if the CRC of this message has been verified. Reception of a Type 0 message from an SBAS satellite shall result in deselection of that satellite and all data from that satellite shall be discarded for at least 1 minute. For GPS satellites, the receiver shall apply long-term corrections only if the IOD matches both the IODE and 8 least significant bits of the IODC. For GLONASS satellites, the receiver shall apply long-term corrections only if the time of reception (t_r) of the GLONASS ephemeris is inside the following IOD validity interval, as defined in 3.5.4.4.1:

$$t_{LT} - L - V \leq t_r \leq t_{LT} - L$$

Note 1.— For SBAS satellites, there is no mechanism that links GEO ranging function data (Type 9 message) and long-term corrections.

Note 2.— This requirement does not imply that the receiver has to stop tracking the SBAS satellite.

3.5.8.1.2.1 *SBAS satellite identification.* Upon acquisition or re-acquisition of an SBAS satellite, the receiver shall not use SBAS satellite data unless the calculated separation between the satellite position derived from its GEO ranging function parameters and the satellite position derived from the almanac message most recently received from the same service provider within the last 15 minutes is less than 200 km.

Note.— This check ensures that a receiver will not mistake one SBAS satellite for another due to cross-correlation during acquisition or re-acquisition.

3.5.8.1.2.2 The receiver shall use integrity or correction data only if the IODP associated with that data matches the IODP associated with the PRN mask.

3.5.8.1.2.3 The receiver shall use SBAS-provided ionospheric data (IGP vertical delay estimate and $GIVEI_i$) only if the $IODI_k$ associated with that data in a Type 26 message matches the $IODI_k$ associated with the relevant IGP band mask transmitted in a Type 18 message.

3.5.8.1.2.4 The receiver shall use the most recently received integrity data for which the $IODF_j$ equals 3 or the $IODF_j$ matches the $IODF_j$ associated with the fast correction data being applied (if corrections are provided).

3.5.8.1.2.5 The receiver shall apply any regional degradation to the $\sigma_{i,UDRE}^2$ as defined by a Type 27 service message. If a Type 27 message with a new IODS indicates a higher $\delta UDRE$ for the user location, the higher $\delta UDRE$ shall be applied immediately. A lower $\delta UDRE$ in a new Type 27 message shall not be applied until the complete set of messages with the new IODS has been received.

3.5.8.1.2.6 The receiver shall apply satellite-specific degradation to the $\sigma_{i,UDRE}^2$ as defined by a Type 28 clock-ephemeris covariance matrix message. The $\delta UDRE$ derived from a Type 28 message shall be applied immediately.

3.5.8.1.2.7 In the event of a loss of four successive SBAS messages, the receiver shall no longer support SBAS-based precision approach or APV operations.

3.5.8.1.2.8 The receiver shall not use a broadcast data parameter after it has timed out as defined in Table B-56.

3.5.8.1.2.9 The receiver shall not use a fast correction if t for the associated RRC exceeds the time-out interval for fast corrections, or if the age of the RRC exceeds $8 t$.

3.5.8.1.2.10 The calculation of the RRC shall be reinitialized if a “Do Not Use” or “Not Monitored” indication is received for that satellite.

3.5.8.1.2.11 For SBAS-based precision approach or APV operations, the receiver shall only use satellites with elevation angles at or above 5 degrees.

3.5.8.1.2.12 The receiver shall no longer support SBAS-based precision approach or APV operation using a particular satellite if the $UDREI_i$ received is greater than or equal to 12.

Table B-56. Data time-out intervals

Data	Associated message types	En-route, terminal, NPA time-out	Precision approach, APV time-out
Clock-ephemeris covariance matrix	28	360	240
SBAS in test mode	0	N/A	N/A
PRN mask	1	600 s	600 s
UDREI	2 to 6, 24	18 s	12 s
Fast corrections	2 to 5, 24	(see Table B-57)	(see Table B-57)
Long-term corrections	24, 25	360 s	240 s
GEO ranging function data	9	360 s	240 s
Fast correction degradation	7	360 s	240 s
Degradation parameters	10	360 s	240 s
Ionospheric grid mask	18	1 200 s	1 200 s
Ionospheric corrections, GIVEI	26	600 s	600 s
Timing data	12	86 400 s	86 400 s
GLONASS time offset	12	600 s	600 s
Almanac data	17	None	None
Service level	27	86 400 s	86 400 s

Note.—The time-out intervals are defined from the end of the reception of a message.

Table B-57. Fast correction time-out interval evaluation

Fast correction	NPA time-out	PA/APV time-out
-----------------	--------------	-----------------

degradation factor indicator (ai)	interval for fast corrections (I _{fc})	interval for fast corrections (I _{fc})
0	180 s	120 s
1	180 s	120 s
2	153 s	102 s
3	135 s	90 s
4	135 s	90 s
5	117 s	78 s
6	99 s	66 s
7	81 s	54 s
8	63 s	42 s
9	45 s	30 s
10	45 s	30 s
11	27 s	18 s
12	27 s	18 s
13	27 s	18 s
14	18 s	12 s
15	18 s	12 s

3.5.8.2 *RANGING FUNCTION*

3.5.8.2.1 *Precision approach and APV operations.* The root-mean-square (1 sigma) of the total airborne error contribution to the error in a corrected pseudo-range for an SBAS satellite at the minimum received signal power level (Chapter 3, 3.7.3.4.4.3) under the worst interference environment as defined in 3.7 shall be less than or equal to 1.8 metres, excluding multipath effects, tropospheric and ionospheric residual errors.

Note.— The aircraft element will bound the errors caused by multipath and troposphere (3.5.8.4.1). For the purpose of predicting service, the multipath error is assumed to be less than 0.6 metres (1 sigma).

3.5.8.2.2 *Departure, en-route, terminal, and non-precision approach operations.* The root-mean-square (1 sigma) of the total airborne contribution to the error in a corrected pseudo-range for an SBAS satellite at the minimum received signal power level (Chapter 3, 3.7.3.4.4.3) under the worst interference environment as defined in 3.7 shall be less than or equal to 5 metres, excluding multipath, tropospheric and ionospheric errors.

3.5.8.2.3 *SBAS satellite position*

3.5.8.2.3.1 *Position computation.* The receiver shall decode Type 9 message and determine the code phase offset and position (X_G, Y_G, Z_G) of the SBAS satellite.

3.5.8.2.3.2 *SBAS satellite identification.* The receiver shall discriminate between SBAS satellites.

Note.— This requirement applies to false acquisition of a satellite due to cross-correlation.

3.5.8.2.4 *Almanac data*

3.5.8.2.4.1 **Recommendation.—** *The almanac data provided by the SBAS should be used for acquisition.*

Note.— Health and status information provided in the GEO almanac data does not override or invalidate data provided in other SBAS messages. The use of bits 0 to 2 by airborne equipment is optional; there are no requirements covering their usage.

3.5.8.3 *GNSS satellite status function.* The receiver shall exclude satellites from the position solution if they are identified as “Do Not Use” by SBAS. If SBAS-provided integrity is used, the receiver shall not be required to exclude GPS satellites based

on the GPS-provided ephemeris health flag as required in 3.1.3.1.1 or to exclude GLONASS satellites based on GLONASS-provided ephemeris health flag as required in 3.2.3.1.1.

Note 1.— In the case of a satellite designated marginal or unhealthy by the core satellite constellation(s) health flag, SBAS may be able to broadcast ephemeris and clock corrections that will allow the user to continue using the satellite.

Note 2.— If satellites identified as “Not Monitored” by SBAS are used in the position solution, integrity is not provided by SBAS. ABAS or GBAS may be used to provide integrity, if available.

3.5.8.4 BASIC AND PRECISE DIFFERENTIAL FUNCTIONS

3.5.8.4.1 *Core satellite constellation(s) ranging accuracy.* The root-mean-square (1 sigma) of the total airborne contribution to the error in a corrected pseudo-range for a GPS satellite at the minimum received signal power level (Chapter 3, 3.7.3.1.7.4) under the worst interference environment as defined in 3.7 shall be less than or equal to 0.4 metres, excluding multipath effects, tropospheric and ionospheric residual errors. The RMS of the total airborne contribution to the error in a corrected pseudo-range for a GLONASS satellite at the minimum received signal power level (Chapter 3, 3.2.5.4) under the worst interference environment as defined in 3.7 shall be less than or equal to 0.8 metres, excluding multipath effects, tropospheric and ionospheric residual errors.

3.5.8.4.2 Precision approach and APV operations

3.5.8.4.2.1 The receiver shall compute and apply long-term corrections, fast corrections, range rate corrections and the broadcast ionospheric corrections. For GLONASS satellites, the ionospheric corrections received from the SBAS shall be multiplied by the square of the ratio of GLONASS to GPS frequencies ($f_{\text{GLONASS}}/f_{\text{GPS}}$)².

3.5.8.4.2.2 The receiver shall use a weighted-least-squares position solution.

3.5.8.4.2.3 The receiver shall apply a tropospheric model such that residual pseudo-range errors have a mean value (μ) less than 0.15 metres and a 1 sigma deviation less than 0.07 metres.

Note.— A model was developed that meets this requirement. Guidance is provided in Attachment D, 6.5.4.

3.5.8.4.2.4 The receiver shall compute and apply horizontal and vertical protection levels defined in 3.5.5.6. In this computation, σ_{tropo} shall be:

$$\frac{1}{0.12 \text{ m}} \frac{0.002 \sin^2 \theta_i}{\sin^2 \theta_i}$$

where θ_i is the elevation angle of the i^{th} satellite.

In addition, σ_{air} shall satisfy the condition that a normal distribution with zero mean and a standard deviation equal to σ_{air} bounds the error distribution for residual aircraft pseudo-range errors as follows:

$$f_n(x) dx = \frac{1}{\sigma} \exp\left(-\frac{x^2}{2\sigma^2}\right) dx \quad \text{for all } x \text{ and } \sigma > 0$$

$$f_n(x) dx = \frac{1}{\sigma} \exp\left(-\frac{x^2}{2\sigma^2}\right) dx \quad \text{for all } x \text{ and } \sigma > 0$$

Where

$f_n(x)$ = probability density function of the residual aircraft pseudo-range error and

$$Q(x) = \frac{1}{\sqrt{\frac{2}{\pi}}} e^{-\frac{x^2}{2}} dx$$

x

Note.— The standard allowance for airborne multipath defined in 3.6.5.5.1 may be used to bound the multipath errors.

3.5.8.4.2.5 The parameters that define the approach path for a single precision approach or APV shall be contained in the FAS data block.

Note 1.— The FAS path is a line in space defined by the landing threshold point/fictitious threshold point (LTP/FTP), flight path alignment point (FPAP), threshold crossing height (TCH) and glide path angle (GPA). The local level plane for the approach is a plane perpendicular to the local vertical passing through the LTP/FTP (i.e. tangent to the ellipsoid at the LTP/FTP). Local vertical for the approach is normal to the WGS-84 ellipsoid at the LTP/FTP. The glide path intercept point (GPIP) is where the final approach path intercepts the local level plane.

Note 2.— For SBAS, FAS data blocks are stored in airborne databases. The format of the data for validation of a cyclic redundancy check is shown in Attachment D, 6.6. It differs from the GBAS FAS data block in 3.6.4.5.

3.5.8.4.2.5.1 FAS data block parameters shall be as follows (see Table B-57A):

Operation type: straight-in approach procedure or other operation types.

Coding: 0 = straight-in approach procedure

1 to 15 = spare

SBAS service provider ID: indicates the service provider associated with this FAS data block.

Coding: See Table B-27.

14 = FAS data block is to be used with GBAS only.

15 = FAS data block can be used with any SBAS service provider.

Airport ID: the three- or four-letter designator used to designate an airport.

Coding: Each character is coded using the lower 6 bits of its IA-5 representation. For each character, b_1 is transmitted first, and 2 zero bits are appended after b_6 , so that 8 bits are transmitted for each character. Only upper case letters, numeric digits and IA-5 “space” are used. The rightmost character is transmitted first. For a three-character airport ID, the rightmost (first transmitted) character shall be IA-5 “space”.

Runway number: the runway orientation, point-in- space final approach course, or SBAS circling only procedure course rounded to the nearest 10 degrees and truncated to two characters.

Coding: 01 to 36 = runway number

Note.— For heliport operations, the runway number value is the integer nearest to one tenth of the final approach course, except when that integer is zero, in which case the runway number is 36.

Runway letter: the one-letter designator used, as necessary, to differentiate between parallel runways.

Coding: 0 = no letter

1 = R (right)

2 = C (centre)

3 = L (left)

Approach performance designator: this field is not used by SBAS.

Route indicator: a “blank” or the one-letter identifier used to differentiate between multiple procedures to the same runway end.

Note.— Procedures are considered to be different even if they only differ by the missed approach segment.

Coding: The letter is coded using bits b₁ through b₅ of its IA-5 representation. Bit b₁ is transmitted first. Only upper case letters, excluding “I” and “O”, or IA-5 “space” (blank) are used. Blank indicates that there is only one procedure to the runway end. For multiple procedures to the same runway end, the route indicator is coded using a letter starting from Z and moving backward in the alphabet for additional procedures.

Reference path data selector (RPDS): this field is not used by SBAS.

Table B-57A. Final approach segment (FAS) data block

Data content	Bits used	Range of values	Resolution
Operation type	4	0 to 15	1
SBAS service provider ID	4	0 to 15	1
Airport ID	32	—	—
Runway number	6	01 to 36	1
Runway letter	2	—	—
Approach performance designator	3	0 to 7	1
Route indicator	5	—	—
Reference path data selector	8	0 to 48	1
Reference path identifier	32	—	—
LTP/FTP latitude	32	±90.0°	0.0005 arcsec
LTP/FTP longitude	32	±180.0°	0.0005 arcsec
LTP/FTP height	16	-512.0 to 6 041.5 m	0.1 m
FPAP latitude	24	±1.0°	0.0005 arcsec
FPAP longitude	24	±1.0°	0.0005 arcsec
Approach TCH (<i>Note 1</i>)	15	0 to 1 638.35 m or 0 to 3 276.7 ft	0.05 m or 0.1 ft
Approach TCH units selector	1	—	—
Glide path angle (GPA)	16	0 to 90.0°	0.01°
Course width	8	80 to 143.75 m	0.25 m
Length offset	8	0 to 2 032 m	8 m
Horizontal alert limit (HAL)	8	0 to 51.0 m	0.2 m
Vertical alert limit (VAL) (<i>Note 2</i>)	8	0 to 51.0 m	0.2 m
Final approach segment CRC	32	—	—

Note 1.— Information can be provided in either feet or metres as indicated by the approach TCH unit selector.

Note 2.— A VAL of 0 indicates that the vertical deviations cannot be used (i.e., a lateral only approach). This does not preclude providing advisory vertical guidance on such approaches, refer to FAA AC 20-138().

Reference path identifier (RPI): four characters used to uniquely designate the reference path. The four characters consist of three alphanumeric characters plus a blank or four alphanumeric characters.

Note.— The best industry practice matches the 2nd and 3rd character encoding to the encoded runway number. The last character is a letter starting from A or a “blank.”

Coding: Each character is coded using bits b_1 through b_6 of its IA-5 representation. For each character, b_1 is transmitted first, and 2 zero bits are appended after b_6 so that 8 bits are transmitted for each character. Only upper case letters, numeric digits and IA-5 “space” are used. The rightmost character is transmitted first. For a three-character reference path identifier, the rightmost (first transmitted) character shall be IA-5 “space”.

Note.— The LTP/FTP is a point over which the FAS path passes at a height above the LTP/FTP height specified by the TCH.

LTP/FTP latitude: the latitude of the LTP/FTP point in arc seconds.

Coding: positive value denotes north
latitude.

negative value denotes south latitude.

LTP/FTP longitude: the longitude of the LTP/FTP point in arc seconds.

Coding: positive value denotes east longitude.

negative value denotes west longitude.

LTP/FTP height: the height of the LTP/FTP above the WGS-84 ellipsoid.

Coding: This field is coded as an unsigned fixed-point number with an offset of -512 metres. A value of zero in this field places the LTP/FTP 512 metres below the earth ellipsoid.

Note.— The FPAP is a point at the same height as the LTP/FTP that is used to define the alignment of the approach. The origin of angular deviations in the lateral direction is defined to be 305 metres (1 000 ft) beyond the FPAP along the lateral FAS path. For an approach aligned with the runway, the FPAP is at or beyond the stop end of the runway.

Δ FPAP latitude: the difference of latitude of the runway FPAP from the LTP/FTP in arc seconds.

Coding: Positive value denotes the FPAP latitude north of LTP/FTP latitude.

Negative value denotes the FPAP latitude south of the LTP/FTP latitude.

Δ FPAP longitude: the difference of longitude of the runway FPAP from the LTP/FTP in arc seconds.

Coding: Positive value indicates the FPAP longitude east of LTP/FTP longitude.

Negative value indicates the FPAP longitude west of LTP/FTP longitude.

Approach TCH: the height of the FAS path above the LTP/FTP defined in either feet or metres as indicated by the TCH units selector.

Approach TCH units selector: the units used to describe the TCH.

Coding: 0 = feet

1 = metres

Glide path angle (GPA): the angle of the FAS path with respect to the horizontal plane tangent to the WGS-84 ellipsoid at the LTP/FTP.

Course width: the lateral displacement from the path defined by the FAS at the LTP/FTP at which full-scale deflection of a course deviation indicator is attained.

Coding: This field is coded as an unsigned fixed-point number with an offset of 80 metres. A value of zero in this field indicates a course width of 80 metres at the LTP/FTP.

Length offset: the distance from the stop end of the runway to the FPAP.

Coding: 1111 1111 = not provided

HAL: Horizontal alert limit to be used during the approach in metres.

VAL: Vertical alert limit to be used during the approach in metres.

Final approach segment CRC: the 32-bit CRC appended to the end of each FAS data block in order to ensure approach data integrity. The 32-bit final approach segment CRC shall be calculated in accordance with 3.9. The length of the CRC code shall be $k = 32$ bits.

The CRC generator polynomial shall be:

$$G(x) = x^{32} + x^{31} + x^{24} + x^{22} + x^{16} + x^{14} + x^8 + x^7 + x^5 + x^3 + x + 1$$

The CRC information field, $M(x)$, shall be:

$$M(x) = \sum_{i=1}^{288} m_i x^{288-i} = m_1 x^{287} + m_2 x^{286} + \dots + m_{288} x^0$$

$M(x)$ shall be formed from all bits of the associated FAS data block, excluding the CRC. Bits shall be arranged in the order transmitted, such that m_1 corresponds to the LSB of the operation type field, and m_{288} corresponds to the MSB of the Vertical Alert Limit (VAL) field. The CRC shall be ordered such that r_1 is the LSB and r_{32} is the MSB.

3.5.8.4.2.5.2 For precision approach and APV operations, the service provider ID broadcast Type 17 message shall be identical to the service provider ID in the FAS data block, except if ID equals 15 in the FAS data block.

Note.— If the service provider ID in the FAS data block equals 15, then any service provider can be used. If the service provider ID in the FAS data block equals 14, then SBAS precise differential corrections cannot be used for the approach.

3.5.8.4.2.5.3 *SBAS FAS data points accuracy.* The survey error of all the FAS data points, relative to WGS-84, shall be less than 0.25 metres vertical and 1 metre horizontal.

3.5.8.4.3 *Departure, en-route, terminal, and non-precision approach operations*

3.5.8.4.3.1 The receiver shall compute and apply long-term corrections, fast corrections and range rate corrections.

3.5.8.4.3.2 The receiver shall compute and apply ionospheric corrections.

Note.— Two methods of computing ionospheric corrections are provided in 3.1.2.4 and 3.5.5.5.2.

3.5.8.4.3.3 The receiver shall apply a tropospheric model such that residual pseudo-range errors have a mean value (μ) less than 0.15 metres and a standard deviation less than 0.07 metres.

Note.— A model was developed that meets this requirement. Guidance is provided in Attachment D, 6.5.4.

3.5.8.4.3.4 The receiver shall compute e and apply horizontal and vertical protection levels as defined in 3.5.5.6. In this computation, σ_{tropo} shall be:

$$\sigma_{\text{tropo}} = \sqrt{0.12^2 + 0.002 \sin^2 \theta_i}$$

where θ_i is the elevation angle of the i^{th} satellite.

In addition, σ_{air} shall satisfy the condition that a normal distribution with zero mean and standard deviation equal to σ_{air} bounds the error distribution for residual aircraft pseudo-range errors as follows:

$$f_n(x) dx = Q \left(\frac{x}{\sigma} \right) \text{ for all } \sigma > 0 \text{ and}$$

$$f_n(x) dx = Q \left(\frac{-x}{\sigma} \right) \text{ for all } \sigma > 0$$

where

$f_n(x)$ = probability density function of the residual aircraft pseudo-range error and

$$Q(x) = \frac{1}{\sqrt{2\pi}} \int_x^{\infty} e^{-\frac{t^2}{2}} dt$$

Note.— The standard allowance for airborne multipath defined in 3.6.5.5.1 may be used to bound the multipath errors.

3.5.8.4.4 Recommendation.— *For departure, en-route, terminal, and non-precision approach operations, the receiver should use the broadcast ionospheric corrections, when available, and a tropospheric model with performance equal to that specified in 3.5.8.4.3.*

3.5.9 INTERFACE BETWEEN SBAS

Note.— Guidance material on the interface between different SBAS service providers is given in Attachment D, 6.3.

3.6 Ground-based augmentation system (GBAS) and ground-based regional augmentation system (GRAS)

Note.— In this section, except where specifically annotated, reference to approach with vertical guidance (APV) means APV-I and APV-II.

3.6.1 GENERAL

The GBAS shall consist of a ground subsystem and an aircraft subsystem. The GBAS ground subsystem shall provide data and corrections for the GNSS ranging signals over a digital VHF data broadcast to the aircraft subsystem. The GRAS ground subsystem shall consist of one or more GBAS ground subsystems.

Note.— Guidance material is provided in Attachment D, 7.1.

3.6.2 RF CHARACTERISTICS

3.6.2.1 Carrier frequency stability. The carrier frequency of the data broadcast shall be maintained within ± 0.0002 per cent of the assigned frequency.

3.6.2.2 *Bit-to-phase-change encoding* . GBAS messages shall be assembled into symbols, each consisting of 3 consecutive message bits. The end of the message shall be padded by 1 or 2 fill bits if necessary to form the last 3-bit symbol of the message. Symbols shall be converted to D8PSK carrier phase shifts (ϕ_k) in accordance with Table B-58.

Note.— The carrier phase for the k^{th} symbol (ϕ_k) is given by: $\phi_k = \phi_{k-1} + \phi_k$. The D8PSK signal may be produced as shown in Figure B-19 by combining two quadrature RF signals which are independently suppressed-carrier amplitude-modulated by base band filtered impulses. A positive increase in ϕ_k represents a counterclockwise rotation in the complex I-Q plane of Figure B-19.

3.6.2.3 *Modulation wave form and pulse shaping filters*. The output of differential phase encoder shall be filtered by a pulse shaping filter whose output, $s(t)$, is described as follows:

$$s(t) = \sum_{k=-\infty}^{\infty} \phi_k h(t - kT)$$

where

- h = the impulse response of the raised cosine filter;
- k = (as defined in 3.6.2.2);
- t = time; and
- T = the duration of each symbol = 1/10 500 second.

This pulse shaping filter shall have a nominal complex frequency response of a raised-cosine filter with $\alpha = 0.6$. The time response, $h(t)$, and frequency response, $H(f)$, of the base band filters shall be as follows:

$$h(t) = \begin{cases} \frac{\sin \frac{\pi t}{T} \cos \frac{\alpha \pi t}{T}}{\frac{\pi t}{T} - \frac{2\alpha t^2}{T}} & \text{for } 0 \leq t \leq T \\ 0 & \text{for } t < 0 \text{ or } t > T \end{cases}$$

$$H(f) = \begin{cases} \frac{1 - \frac{\alpha}{2} \frac{\pi}{2\pi f T}}{\sin \frac{\alpha \pi}{2\pi f T}} & \text{for } 0 \leq f \leq \frac{\alpha}{2T} \\ \frac{1}{2} & \text{for } \frac{\alpha}{2T} \leq f \leq \frac{1}{T} \\ 0 & \text{for } f > \frac{1}{T} \end{cases}$$

The output $s(t)$ of the pulse shaping filter shall modulate the carrier.

3.6.2.4 *Error vector magnitude*. The error vector magnitude of the transmitted signal shall be less than 6.5 per cent root-mean-square (1 sigma).

3.6.2.5 *RF data rate*. The symbol rate shall be 10 500 symbols per second ± 0.005 per cent, resulting in a nominal bit rate of 31 500 bits per second.

Table B-58. Data encoding

Message bits	Symbol phase shift
--------------	--------------------

I_{3k-2}	I_{3k-1}	I_{3k}	k	
0	0	0		$0\pi/4$
0	0	1		$1\pi/4$
0	1	1		$2\pi/4$
0	1	0		$3\pi/4$
1	1	0		$4\pi/4$
1	1	1		$5\pi/4$
1	0	1		$6\pi/4$
1	0	0		$7\pi/4$

Note.— I_j is the j^{th} bit of the burst to be transmitted, where I_1 is the first bit of the training sequence.

3.6.2.6 *Emissions in unassigned time slots.* Under all operating conditions, the maximum power over a 25 kHz channel bandwidth, centred on the assigned frequency, when measured over any unassigned time slot, shall not exceed -105 dBc referenced to the authorized transmitter power.

Note.— If the authorized transmitter power is higher than 150 W, the -105 dBc may not protect reception of emissions in a slot assigned to another desired transmitter for receivers within 200 metres from the undesired transmitting antenna.

3.6.3 DATA STRUCTURE

3.6.3.1 TRANSMITTER TIMING

3.6.3.1.1 *Data broadcast timing structure.* The time division multiple access (TDMA) timing structure shall be based on frames and time slots. Each frame shall be 500 milliseconds in duration. There shall be 2 such frames contained in each 1-second UTC epoch. The first of these frames shall start at the beginning of the UTC epoch and the second frame shall start 0.5 seconds after the beginning of the UTC epoch. The frame shall be time division multiplexed such that it shall consist of 8 individual time slots (A to H) of 62.5-millisecond duration.

3.6.3.1.2 *Bursts.* Each assigned time slot shall contain at most 1 burst. To initiate the use of a time slot, the GBAS shall broadcast a burst in that time slot in each of 5 consecutive frames. For each time slot in use, the ground subsystem shall broadcast a burst in at least 1 frame of every 5 consecutive frames.

Note 1.— *Bursts contain one or more messages and may be of variable length up to the maximum allowed within the slot as required by 3.6.3.2.*

Note 2.— *During time slot initiation, the airborne receiver may not receive the first 4 bursts.*

3.6.3.1.3 Timing budget for bursts

3.6.3.1.3.1 Each burst shall be contained in a 62.5-millisecond time slot.

3.6.3.1.3.2 The beginning of the burst shall occur 95.2 microseconds after the beginning of the time slot with a tolerance of ± 95.2 microseconds.

3.6.3.1.3.3 For GBAS/E equipment, the start of the synchronization and ambiguity resolution portion of the burst, transmitted with horizontal polarization (HPOL), shall occur within 10 microseconds of the start of the burst transmitted with vertical polarization (VPOL).

Note.— *Table B-59 illustrates the burst timing.*

3.6.3.1.4 *Ramp-up and transmitter power stabilization*. The transmitter shall ramp up to 90 per cent of the steady-state power level within 190.5 microseconds after the beginning of the burst (2 symbols). The transmitter shall stabilize at the steady-state power within 476.2 microseconds after the beginning of the burst (5 symbols).

Note.— *The transmitter power stabilization period may be used by the aircraft receiver to settle its automatic gain control.*

3.6.3.1.5 *Ramp-down*. After the final information symbol is transmitted in an assigned time slot, the transmitter output power level shall decrease to at least 30 dB below the steady-state power within 285.7 microseconds (3 symbols).

3.6.3.2 *Burst organization and coding*. Each burst shall consist of the data elements shown in Table B-60. Encoding of the messages shall follow the sequence: application data formatting, training sequence forward error correction (FEC) generation, application FEC generation and bit scrambling.

3.6.3.2.1 *Synchronization and ambiguity resolution*. The synchronization and ambiguity resolution field shall consist of the 48-bit sequence shown below, with the rightmost bit transmitted first:

010 001 111 101 111 110 001 100 011 101 100 000 011 110 010 000

Table B-59. Burst timing

Event	Nominal event duration	Nominal percentage of steady-state power
Ramp-up	190.5 μs	0% to 90%
Transmitter power stabilization	285.7 μs	90% to 100%
Synchronization and ambiguity resolution	1 523.8 μs	100%
Transmission of scrambled data	58 761.9 μs	100%
Ramp-down	285.7 μs (<i>Note 1</i>)	100% to 0%

Notes.—

1. *Event duration indicated for transmission of scrambled data is for maximum application data length of 1 776 bits, 2 fill bits and nominal symbol duration.*

2. *These timing requirements provide a propagation guard time of 1 259 microseconds, allowing for a one-way propagation range of approximately 370 km (200 NM).*

3. *Where bursts from a GBAS broadcast antenna can be received at a range more than 370 km (200 NM) greater than the range from another broadcast antenna using the next adjacent slot, a longer guard time is required to avoid loss of both bursts. To provide a longer guard time, it is necessary to limit the application data length of the first burst to 1 744 bits. This allows a difference in propagation ranges of up to 692 km (372 NM) without conflict.*

Table B-60. Burst data content

Element	Data content	Number of bits
---------	--------------	----------------

Beginning of burst	all zeros	15
Power stabilization		
Synchronization and ambiguity resolution	3.6.3.2.1	48
Scrambled data:	3.6.3.3	
station slot identifier (SSID)	3.6.3.3.1	3
transmission length	3.6.3.3.2	17
training sequence FEC	3.6.3.3.3	5
application data	3.6.3.3.4	up to 1 776
application FEC	3.6.3.3.5	48
fill bits (Note)	3.6.2.2	0 to 2

Note.— Data scrambling of the fill bits is optional (3.6.3.3.6).

3.6.3.3 SCRAMBLED DATA CONTENT

3.6.3.3.1 Station slot identifier (SSID). The SSID shall be a numeric value corresponding to the letter designation A to H of the first time slot assigned to the GBAS ground subsystem, where slot A is represented by 0, B by 1, C by 2, ... and H by 7. The identifier is transmitted LSB first.

3.6.3.3.2 Transmission length. The transmission length shall indicate the total number of bits in both application data and application FEC. The transmission length is transmitted LSB first.

3.6.3.3.3 Training sequence FEC. The training sequence FEC shall be computed over the SSID and transmission length fields, using a (25, 20) block code, in accordance with the following equation:

$$[P_1, \dots, P_5] = [SSID_1, \dots, SSID_3, TL_1, \dots, TL_{17}] H^T$$

where

- P_n = the n^{th} bit of the training sequence FEC (P_1 shall be transmitted first);
- $SSID_n$ = the n^{th} bit of the station slot identifier ($SSID_1 = \text{LSB}$);
- TL_n = the n^{th} bit in the transmission length ($TL_1 = \text{LSB}$); and
- H^T = the transpose of the parity matrix, defined below:

$$H^T = \begin{bmatrix} 00000000111111111111 \\ 00111111000011111111 \\ 11000111001100001111 \\ 11011011010100110011 \\ 01101001111001010101 \end{bmatrix}$$

Note.— This code is capable of correcting all single bit errors and detecting 75 of 300 possible double bit errors.

3.6.3.3.4 Application data. The application data shall consist of one or more message blocks, as defined in 3.6.3.4. The message blocks shall be mapped directly into the application data with no additional overhead of intervening layers.

3.6.3.3.5 Application FEC. The application FEC shall be calculated using the application data by means of a systematic, fixed-length, Reed-Solomon (R-S) (255, 249) code.

3.6.3.3.5.1 The field-defining primitive, $p(x)$, of the R-S code shall be:

$$p(x) = x^8 + x^7 + x^2 + x + 1$$

3.6.3.3.5.2 The generator polynomial of the R-S code, $g(x)$, shall be:

$$g(x) = (x - \alpha^i)^5 (x - \alpha^{176})^5 (x - \alpha^{186})^4 (x - \alpha^{244})^3 (x - \alpha^{176})^2 (x - \alpha^{156}) (x - \alpha^{225})$$

where α is a root of $p(x)$ used for construction of the Galois Field of size 2^8 , GF(256), and α^i is the i^{th} primitive element in GF(256).

3.6.3.3.5.3 In generating the application FEC, the data to be encoded, $m(x)$, shall be grouped into 8-bit R-S symbols. All data fields in the message blocks that define the application data shall be ordered such as specified in Tables B-61 and B-62, and in the message tables in 3.6.6. However, since the R-S code is a block code, application data blocks shorter than 249 bytes (1 992 bits) shall be extended to 249 bytes by virtual fill bits set to zero and appended to the application data. These virtual fill bits shall not be transferred to the bit scrambler. The data to be encoded, $m(x)$, shall be defined by:

$$m(x) = a_{248}x^{248} + a_{247}x^{247} + \dots + a_{248-\text{length}+1}x^{248-\text{length}+1} + a_{248-\text{length}}x^{248-\text{length}} + \dots + a_1x + a_0$$

where

length represents the number of 8-bit bytes in the application data block;

a_{248} represents the message block identifier, with the rightmost bit defined as the LSB and the first bit of the application data sent to the bit scrambler;

$a_{248-\text{length}+1}$ represents the last byte of the message block CRC, with the leftmost bit defined as the MSB and the last bit of the application data sent to the bit scrambler; and

$a_{248-\text{length}}, \dots, a_1, a_0$ are the virtual fill bits (if any).

3.6.3.3.5.4 The 6 R-S check symbols (b_i) shall be defined as the coefficients of the remainder resulting from dividing the message polynomial $x^6 m(x)$ by the generator polynomial $g(x)$:

$$x^6 m(x) \bmod g(x) = b_5 x^5 + b_4 x^4 + b_3 x^3 + b_2 x^2 + b_1 x + b_0$$

3.6.3.3.5.5 The 8-bit R-S check symbols shall be appended to the application data. Each 8-bit R-S check symbol shall be transmitted MSB first from b_0 to b_5 , i.e. the first application FEC bit transferred to the bit scrambler shall be the MSB of b_0 and the last application FEC bit transferred to the bit scrambler shall be the LSB of b_5 .

Note 1.— This R-S code is capable of correcting up to 3 symbol errors.

Note 2.— The order of the transmitted 8-bit R-S check symbols of the appended application FEC differs from the VHF data link (VDL) Mode 2. Moreover, for VDL Mode 2 each R-S check symbol is transmitted LSB first.

Note 3.— Example results of application FEC encoding are given in Attachment D, 7.15.

Table B-61. Format of a GBAS message block

Message block	Bits
Message block header	48
Message	up to 16
CRC	32

Table B-62. Format of message block header

Data field	Bits
Message block identifier	8
GBAS ID	24
Message type identifier	8
Message length	8

3.6.3.3.6 Bit scrambling

3.6.3.3.6.1 The output of a pseudo-noise scrambler with a 15-stage generator register shall be exclusive OR'ed with the burst data starting with the SSID and ending with the application FEC. Bit scrambling of the fill bits is optional and the set value of the fill bits is optional.

Note.— The fill bits are not used by the aircraft receiver and their values have no impact on the system.

3.6.3.3.6.2 The polynomial for the register taps of the scrambler shall be $1 + x + x^{15}$. The register content shall be rotated at the rate of one shift per bit. The initial status of the register, prior to the first SSID bit of each burst, shall be “1101 0010 1011 001”, with the leftmost bit in the first stage of the register. The first output bit of the scrambler shall be sampled prior to the first register shift.

Note.— A diagram of the bit scrambler is given in Attachment D, 7.4.

3.6.3.4 Message block format. The message blocks shall consist of a message block header, a message and a 32-bit CRC. Table B-61 shows the construction of the message block. All signed parameters shall be two's complement numbers and all unsigned parameters shall be unsigned fixed point numbers. The scaling of the data shall be as shown in the message tables in 3.6.6. All data fields in the message block shall be transmitted in the order specified in the message tables, with the LSB of each field transmitted first.

Note.— All binary representations reading left to right are MSB to LSB.

3.6.3.4.1 Message block header. The message block header shall consist of a message block identifier, a GBAS identifier (ID), a message type identifier and a message length, as shown in Table B-62.

Message block identifier: the 8-bit identifier for the operating mode of the GBAS message block.

Coding: 1010 1010 = normal GBAS message
 1111 1111 = test GBAS message

All other values are reserved.

GBAS ID: the four-character GBAS identification to differentiate between GBAS ground subsystems.

Coding: Each character is coded using bits b_1 through b_6 of its International Alphabet No. 5 (IA-5) representation. For each character, bit b_1 is transmitted first and six bits are transmitted for each character. Only upper case letters, numeric digits and IA-5 “space” are used. The rightmost character is transmitted first. For a three-character GBAS ID, the rightmost (first transmitted) character shall be IA-5 “space”.

Note.— The GBAS ID is normally identical to the location indicator at the nearest airport. Assignment of GBAS IDs will be coordinated as appropriate to avoid conflicts.

Message type identifier: the numeric label identifying the content of the message (Table B-63).

Message length: the length of the message in 8-bit bytes including the 6-byte message block header, the message and the 4-byte message CRC code.

3.6.3.4.2 *Cyclic redundancy check (CRC).* The GBAS message CRC shall be calculated in accordance with 3.9.

3.6.3.4.2.1 The length of the CRC code shall be $k = 32$ bits.

3.6.3.4.2.2 The CRC generator polynomial shall be:

$$G(x) = x^{32} + x^{31} + x^{24} + x^{22} + x^{16} + x^{14} + x^8 + x^7 + x^5 + x^3 + x$$

+ 1 3.6.3.4.2.3 The CRC information field, $M(x)$, shall be:

$$M(x) = m_n x^{n-1} + m_{n-1} x^{n-2} + m_{n-2} x^{n-3} + \dots + m_1 x^0$$

3.6.3.4.2.4 $M(x)$ shall be formed from the 48-bit GBAS message block header and all bits of the variable-length message, excluding the CRC. Bits shall be arranged in the order transmitted, such that m_1 corresponds to the first transmitted bit of the message block header, and m_n corresponds to the last transmitted bit of the $(n-48)$ message bits.

3.6.3.4.2.5 The CRC shall be ordered such that r_1 is the first bit transmitted and r_{32} is the last bit transmitted.

3.6.4 DATA CONTENT

3.6.4.1 *Message types.* The message types that can be transmitted by GBAS shall be as in Table B-63.

3.6.4.2 TYPE 1 MESSAGE — PSEUDO-RANGE CORRECTIONS

3.6.4.2.1 The Type 1 message shall provide the differential correction data for individual GNSS ranging sources (Table B-70). The message shall contain three sections:

- a) message information (time of validity, additional message flag, number of measurements and the measurement type);
- b) low-frequency information (ephemeris decorrelation parameter, satellite ephemeris CRC and satellite availability information); and
- c) satellite data measurement blocks.

Note.— Transmission of the low-frequency data for SBAS ranging sources is optional.

3.6.4.2.2 Each Type 1 message shall include ephemeris decorrelation parameter, ephemeris CRC and source availability duration parameters for one satellite ranging source. The ephemeris decorrelation parameter, ephemeris CRC and source availability duration shall apply to the first ranging source in the message.

3.6.4.2.3 Pseudo-range correction parameters shall be as follows:

Modified Z-count: the indication of the time of applicability for all the parameters in the message.

Coding: the modified Z-count resets on the hour (xx:00), 20 minutes past the hour (xx:20) and 40 minutes past the hour (xx:40) referenced to GPS time.

Additional message flag: an identification of whether the set of measurement blocks in a single frame for a particular measurement type is contained in a single Type 1 message or a linked pair of messages.

Coding: 0 = All measurement blocks for a particular measurement type are contained in one Type 1 message.

1 = This is the first transmitted message of a linked pair of Type 1 messages that together contain the set of all measurement blocks for a particular measurement type.

2 = Spare

3 = This is the second transmitted message of a linked pair of Type 1 messages that together contain the set of all measurement blocks for a particular measurement type.

Note.— When a linked pair of Type 1 messages is used for a particular measurement type, the number of measurements and low-frequency data are computed separately for each of the two individual messages.

Number of measurements: the number of measurement blocks in the message.

Measurement type: the type of ranging signal from which the corrections have been computed.

Table B-63. GBAS VHF data broadcast messages

Message type identifier	Message name
0	Spare
1	Pseudo-range corrections
2	GBAS-related data
3	Null message
4	Final approach segment (FAS) data
5	Predicted ranging source availability
6	Reserved
7	Reserved for national applications
8	Reserved for test applications
9 to 100	Spare
101	GRAS pseudo-range corrections
102 to 255	Spare

Note.— See 3.6.6 for message formats.

Coding: 0 = C/A or CSA code L1

- 1 = reserved
- 2 = reserved
- 3 = reserved
- 4 to 7 = spare

Ephemeris decorrelation parameter (P): a parameter that characterizes the impact of residual ephemeris errors due to decorrelation for the first measurement block in the message.

For a SBAS geostationary satellite, the ephemeris decorrelation parameter, if transmitted, shall be coded as all zeros.

For GBAS ground subsystems that do not broadcast the additional data block 1 in the Type 2 message, the ephemeris decorrelation parameter shall be coded as all zeros.

Ephemeris CRC: the CRC computed with the ephemeris data used to determine corrections for the first measurement block in the message. The ephemeris CRC for core satellite constellation(s) ranging sources shall be calculated in accordance with 3.9. The length of the CRC code shall be $k = 16$ bits. The CRC generator polynomial shall be:

$$G(x) = x^{16} + x^{12} + x^5 + 1$$

The CRC information field, $M(x)$, for a given satellite shall be:

$$M(x) = m_{n-1}x^{n-1} + m_{n-2}x^{n-2} + \dots + m_1x + m_0$$

For a GPS satellite, $M(x)$ shall be of length $n = 576$ bits. $M(x)$ for a GPS satellite shall be calculated using the first 24 bits from each of words 3 to S10 of subframes 1, 2 and 3 of the data transmission from that satellite, ANDed with the GPS satellite ephemeris mask of Table B-64. $M(x)$ shall be arranged in the order that bytes are transmitted by the GPS satellite, but with each byte ordered LSB first, such that m_1 corresponds to bit 68 of subframe 1, and m_{576} corresponds to bit 287 of subframe 3.

Note.— $M(x)$ for a GPS satellite does not include word 1 (TLM) or word 2 (HOW), which start each subframe, or the 6 parity bits at the end of each word.

For a GLONASS satellite, $M(x)$ shall be of length $n = 340$ bits. $M(x)$ for a GLONASS satellite shall be calculated using strings 1, 2, 3 and 4 of the data transmission from that satellite, ANDed with the GLONASS satellite ephemeris mask of Table B-65. Bits shall be arranged in transmission order such that m_1 corresponds to bit 85 of string 1, and m_{340} corresponds to bit 1 of string 4.

For a SBAS geostationary satellite, the ephemeris CRC, if transmitted shall be coded as all zeros.

The CRC shall be transmitted in the order $r_9, r_{10}, r_{11}, \dots, r_{16}, r_1, r_2, r_3, \dots, r_8$, where r_i is the i^{th} coefficient of the remainder $R(x)$ as defined in 3.9.

Source availability duration: the predicted duration for which corrections for the ranging source are expected to remain available, relative to the modified Z-count for the first measurement block.

Coding: 1111 1110 = The duration is greater than or equal to 2 540 seconds.

1111 1111 = Prediction of source availability duration is not provided by this ground subsystem.

3.6.4.2.4 The measurement block parameters shall be as follows:

Ranging source ID: the identity of the ranging source to which subsequent measurement block data are applicable.

Table B-64. GPS satellite ephemeris mask

Subframe 1:	Byte 1	Byte 2	Byte 3	Byte 1	Byte 2	Byte 3
Word 3	0000 0000	0000 0000	0000 0011	Word 4	0000 0000	0000 0000
Word 5	0000 0000	0000 0000	0000 0000	Word 6	0000 0000	0000 0000
Word 7	0000 0000	0000 0000	1111 1111	Word 8	1111 1111	1111 1111
Word 9	1111 1111	1111 1111	1111 1111	Word 10	1111 1111	1111 1100
Subframe 2:	Byte 1	Byte 2	Byte 3	Byte 1	Byte 2	Byte 3
Word 3	1111 1111	1111 1111	1111 1111	Word 4	1111 1111	1111 1111
Word 5	1111 1111	1111 1111	1111 1111	Word 6	1111 1111	1111 1111
Word 7	1111 1111	1111 1111	1111 1111	Word 8	1111 1111	1111 1111
Word 9	1111 1111	1111 1111	1111 1111	Word 10	1111 1111	0000 0000
Subframe 3:	Byte 1	Byte 2	Byte 3	Byte 1	Byte 2	Byte 3
Word 3	1111 1111	1111 1111	1111 1111	Word 4	1111 1111	1111 1111
Word 5	1111 1111	1111 1111	1111 1111	Word 6	1111 1111	1111 1111
Word 7	1111 1111	1111 1111	1111 1111	Word 8	1111 1111	1111 1111
Word 9	1111 1111	1111 1111	1111 1111	Word 10	1111 1111	1111 1100

Table B-65. GLONASS satellite ephemeris mask

String 1:
0 0000 0000 0000 0000 0000 1111 1111 1111 1111 1111 1111 1111 1111
1111 1111 1111 1111 1111 1111 1111 0000 0000
String 2:
0 0000 0000 0000 0000 0000 1111 1111 1111 1111 1111 1111 1111 1111
1111 1111 1111 1111 1111 1111 1111 0000 0000
String 3:
0 0000 0111 1111 1111 0000 1111 1111 1111 1111 1111 1111 1111 1111
1111 1111 1111 1111 1111 1111 1111 0000 0000
String 4:
0 0000 1111 1111 1111 1111 1111 1100 0000 0000 0000 0000 0000
0000 0000 0000 0000 0000 0000 0000 0000 0000 0000

Coding: 1 to 36 = GPS satellite IDs (PRN)
 37 = reserved
 38 to 61 = GLONASS satellite IDs (slot number plus 37)
 62 to 119 = spare
 120 to 138 = SBAS satellite IDs (PRN)
 139 to 255 = spare

Issue of data (IOD): The issue of data associated with the ephemeris data used to determine pseudo-range and range rate corrections.

Coding: for GPS, IOD = GPS IODE parameter (3.1.1.3.2.2)
for GLONASS, = GLONASS “tb” parameter (see
IOD 3.2.1.3.1)
for SBAS, IOD = 1111 1111

Note.— For GLONASS insert 0 in the MSB of the IOD.

Pseudo-range correction (PRC): the correction to the ranging source pseudo-range.

Range rate correction (RRC): the rate of change of the pseudo-range correction.

σ_{pr_gnd} : the standard deviation of a normal distribution associated with the signal-in-space contribution of the pseudo-range error at the GBAS reference point (3.6.5.5.1, 3.6.5.5.2 and 3.6.7.2.2.4).

Coding: 1111 1111 = Ranging source correction invalid.

B_1 through B_4 : are the integrity parameters associated with the pseudo-range corrections provided in the same measurement block. For the i^{th} ranging source these parameters correspond to $B_{i,1}$ through $B_{i,4}$ (3.6.5.5.1.2, 3.6.5.5.2.2 and 3.6.7.2.2.4). The indices “1-4” correspond to the same physical reference receiver for every frame transmitted from a given ground subsystem during continuous operation.

Coding: 1000 0000 = Reference receiver was not used to compute the pseudo-range correction.

Note.— Some airborne receivers may expect a static correspondence of the reference receivers to the indices for short service interruptions. However, the B-value indices may be reassigned after the ground subsystem has been out of service for an extended period of time, such as for maintenance.

3.6.4.3 *Type 2 message — GBAS-related data.* Type 2 message shall identify the location of the GBAS reference point at which the corrections provided by the GBAS apply and shall give other GBAS-related data (Table B-71). GBAS-related data parameters shall be as follows:

Note.— Additional data blocks may be included in the Type 2 message. Additional data block 1 and additional data block 2 are defined. In the future, other additional data blocks may be defined. Data blocks 2 through 255 are variable length and may be appended to the message after additional data block 1 in any order.

GBAS reference receivers: the number of GNSS reference receivers installed in this GBAS ground subsystem.

Coding: 0 = GBAS installed with 2 reference receivers
1 = GBAS installed with 3 reference receivers
2 = GBAS installed with 4 reference receivers
3 = The number of GNSS reference receivers installed in this GBAS ground subsystem is not applicable

Ground accuracy designator letter: the letter designator indicating the minimum signal-in-space accuracy performance provided by GBAS (3.6.7.1.1).

Coding: 0 = accuracy designation A
1= accuracy designation B
2= accuracy designation C
3= spare

GBAS continuity/integrity designator (GCID): numeric designator indicating the operational status of the GBAS.

Coding: 0 = spare
1 = GCID 1
2 = GCID 2
3 = GCID 3
4 = GCID 4
5 = spare
6 = spare
7 = unhealthy

Note 1.— The values of GCID 2, 3 and 4 are specified in order to ensure compatibility of equipment with future GBAS.

Note 2.— The value of GCID 7 indicates that a precision approach or APV cannot be initiated.

Local magnetic variation: the published magnetic variation at the GBAS reference point.

Coding: Positive value denotes east variation (clockwise from true north), Negative value denotes west variation (counter-clockwise from true north)

100 0000 0000 = Precision approach procedures supported by this GBAS are published based on true bearing.

Note.— Local magnetic variation is chosen to be consistent with procedure design and is updated during magnetic epoch years.

$\sigma_{vert_iono_gradient}$: the standard deviation of a normal distribution associated with the residual ionospheric uncertainty due to spatial decorrelation (3.6.5.4).

Refraction index (N_r): the nominal tropospheric refractivity index used to calibrate the tropospheric correction associated with the GBAS ground subsystem (3.6.5.3).

Coding: This field is coded as two's complement number with an offset of +400. A value of zero in this field indicates a refractivity index of 400.

Scale height (h_o): a scale factor used to calibrate the tropospheric correction and residual tropospheric uncertainty associated with the GBAS ground subsystem (3.6.5.3).

Refraction uncertainty (σ_n): the standard deviation of a normal distribution associated with the residual tropospheric uncertainty (3.6.5.3).

Latitude: the latitude of the GBAS reference point defined in arc seconds.

Coding: Positive value denotes north latitude.

Negative value denotes south latitude.

Longitude: the longitude of the GBAS reference point defined in arc seconds.

Coding: Positive value denotes east longitude.

Negative value denotes west longitude.

Reference point height: the height of the GBAS reference point above the WGS-84 ellipsoid.

3.6.4.3.1 *Additional data block 1 parameters.* Additional data block 1 parameters shall be as follows:

REFERENCE STATION DATA SELECTOR (RSDS): the numerical identifier that is used to select the GBAS ground subsystem.

Note.— The RSDS is different from every other RSDS and every reference path data selector (RPDS) broadcast on the same frequency by every GBAS ground subsystem within the broadcast region.

Coding: 1111 1111 = GBAS positioning service is not provided

MAXIMUM USE DISTANCE (D_{max}): the maximum distance (slant range) from the GBAS reference point for which the integrity is assured.

Note.— This parameter does not indicate a distance within which VHF data broadcast field strength requirements are met.

Coding: 0 = No distance limitation

GPS EPHEMERIS MISSED DETECTION PARAMETER, GBAS Positioning Service ($K_{md_e_POS, GPS}$): the multiplier for computation of the ephemeris error position bound for the GBAS positioning service derived from the probability of missed detection given that there is an ephemeris error in a GPS satellite.

For GBAS ground subsystems that do not broadcast corrections for GPS ranging sources or that do not provide the GBAS positioning service, this parameter shall be coded as all zeros.

GPS EPHEMERIS MISSED DETECTION PARAMETER, Category I Precision Approach and APV ($K_{md_e_GPS}$): the multiplier for computation of the ephemeris error position bound for Category I precision approach and APV derived from the probability of missed detection given that there is an ephemeris error in a GPS satellite.

For GBAS ground subsystems that do not broadcast corrections for GPS ranging sources, this parameter shall be coded as all zeros.

GLONASS EPHEMERIS MISSED DETECTION PARAMETER, GBAS Positioning Service ($K_{md_e_POS, GLONASS}$): the multiplier for computation of the ephemeris error position bound for the GBAS positioning service derived from the probability of missed detection given that there is an ephemeris error in a GLONASS satellite.

For GBAS ground subsystems that do not broadcast corrections for GLONASS ranging sources or that do not provide positioning service, this parameter shall be coded as all zeros.

GLONASS EPHEMERIS MISSED DETECTION PARAMETER, Category I Precision Approach and APV ($K_{md_e_GLONASS}$): the multiplier for computation of the ephemeris error position bound for Category I precision approach and APV derived from the probability of missed detection given that there is an ephemeris error in a GLONASS satellite.

For GBAS ground subsystems that do not broadcast corrections for GLONASS ranging sources, this parameter shall be coded as all zeros.

3.6.4.3.2 *Additional data blocks.* For additional data blocks other than additional data block 1, the parameters for each data block shall be as follows:

ADDITIONAL DATA BLOCK LENGTH : the number of bytes in the additional data block, including the additional data block length and additional data block number fields.

ADDITIONAL DATA BLOCK NUMBER: the numerical identifier of the type of additional data block.

Coding: 0 to 1 = reserved
2 = additional data block 2, GRAS broadcast stations
3 = reserved for future services supporting Category II/III operations
4 = additional data block 4, VDB authentication parameters
5 to 255 = spare

ADDITIONAL DATA PARAMETERS: the set of data defined in accordance with the additional data block number.

3.6.4.3.2.1 *GRAS broadcast stations*

Parameters for additional data block 2 shall include data for one or more broadcast stations as follows (Table B-65A):

CHANNEL NUMBER: the channel number, as defined in 3.6.5.7, associated with a GBAS broadcast station.

Note.— *The channel number in this field refers to a frequency and an RSDS.*

ΔLATITUDE: the difference of latitude of a GBAS broadcast station, measured from the latitude provided in the latitude parameter of Type 2 message.

Coding: Positive value denotes that the GBAS broadcast station is north of the GBAS reference point.
Negative value denotes that the GBAS broadcast station is south of the GBAS reference point.

ΔLONGITUDE: the difference of longitude of a GBAS broadcast station, measured from the longitude provided in the longitude parameter of Type 2 message.

Coding: Positive value denotes that the GBAS broadcast station is east of the GBAS reference point.
Negative value denotes that the GBAS broadcast station is west of the GBAS reference point.

Note.— *Guidance material concerning additional data block 2 is provided in Attachment D, 7.17.*

3.6.4.3.2.2 *VDB authentication parameters*

Additional data block 4 includes information needed to support VDB authentication protocols (Table B-65B).

Slot group definition: This 8-bit field indicates which of the 8 slots (A-H) are assigned for use by the ground station. The field is transmitted LSB first. The LSB corresponds to slot A, the next bit to slot B, and so on. A “1” in the bit position indicates the slot is assigned to the ground station. A “0” indicates the slot is not assigned to the ground station.

Table B-65A. GRAS broadcast station data

Data content	Bits used	Range of values	Resolution
Channel number	16	20001 to 39999	1
Latitude	8	±25.4°	0.2°
Longitude	8	±25.4°	0.2°

Table B-65B. VDB authentication parameters

Data content	Bits used	Range of values	Resolution
Slot group definition	8	—	—

3.6.4.4 *TYPE 3 MESSAGE — NULL MESSAGE*

3.6.4.4.1 The Type 3 message is a variable length “null message” which is intended to be used by ground subsystems that support the authentication protocols (see section 3.6.7.4).

3.6.4.4.2 The parameters for the Type 3 message shall be as follows:

Filler: a sequence of bits alternating between “1” and “0” with a length in bytes that is 10 less than the value in the message length field in the message header.

3.6.4.5 *Type 4 message — Final approach segment (FAS)*. Type 4 message shall contain one or more sets of FAS data, each defining a single precision approach (Table B-72). Each Type 4 message data set shall include the following:

Data set length: the number of bytes in the data set. The data set includes the data set length field and the associated FAS data block, FAS vertical alert limit (FASVAL)/approach status and FAS lateral alert limit (FASLAL)/approach status fields.

FAS data block: the set of parameters to identify a single precision approach or APV and define its associated approach path.

Coding: See 3.6.4.5.1 and Table B-66.

Note.— *Guidance material for FAS path definition is contained in Attachment D, 7.11.*

FASVAL/approach status: the value of the parameter FASVAL as used in 3.6.5.6.

Coding: 1111 1111 = Do not use vertical deviations.

Note.— *The range and resolution of values for FASVAL depend upon the approach performance designator in the associated FAS data block.*

FASLAL/approach status: the value of the parameter FASLAL as used in 3.6.5.6.

Coding: 1111 1111 = Do not use approach.

3.6.4.5.1 *FAS data block*. The FAS data block shall contain the parameters that define a single precision approach or APV. The FAS path is a line in space defined by the landing threshold point/fictitious threshold point (LTP/FTP), flight path alignment point (FPAP), threshold crossing height (TCH) and glide path angle (GPA). The local level plane for the approach is a plane perpendicular to the local vertical passing through the LTP/FTP (i.e. tangent to the ellipsoid at the LTP/FTP). Local vertical for the approach is normal to the WGS-84 ellipsoid at the LTP/FTP. The glide path intercept point (GPIP) is where the final approach path intercepts the local level plane. FAS data block parameters shall be as follows:

Operation type: straight-in approach procedure or other operation types.

Coding: 0 = straight-in approach procedure

1 to 15 = spare

Table B-66. Final approach segment (FAS) data block

Data content	Bits used	Range of values	Resolution
Operation type	4	0 to 15	1
SBAS provider ID	4	0 to 15	1
Airport ID	32	—	—
Runway number	6	1 to 36	1
Runway letter	2	—	—
Approach performance designator	3	0 to 7	1
Route indicator	5	—	—
Reference path data selector	8	0 to 48	1

Reference path identifier	32	—	—
LTP/FTP latitude	32	±90.0°	0.0005 arcsec
LTP/FTP longitude	32	±180.0°	0.0005 arcsec
LTP/FTP height	16	−512.0 to 6 041.5 m	0.1 m
FPAP latitude	24	±1.0°	0.0005 arcsec
FPAP longitude	24	±1.0°	0.0005 arcsec
Approach TCH (Note)	15	0 to 1 638.35 m or 0 to 3 276.7 ft	0.05 m or 0.1 ft
Approach TCH units selector	1	—	—
GPA	16	0 to 90.0°	0.01°
Course width	8	80 to 143.75 m	0.25 m
Length offset	8	0 to 2 032 m	8 m
Final approach segment CRC	32	—	—

Note.— Information can be provided in either feet or metres as indicated by the approach TCH unit selector.

SBAS service provider ID: indicates the service provider associated with this FAS data block.

Coding: See Table B-27.

14 = FAS data block is to be used with GBAS only.

15 = FAS data block can be used with any SBAS service provider.

Note.— This parameter is not used for approaches conducted using GBAS or GRAS pseudo-range corrections.

Airport ID: the three- or four-letter designator used to designate an airport.

Coding: Each character is coded using the lower 6 bits of its IA-5 representation. For each character, b_1 is transmitted first, and 2 zero bits are appended after b_6 , so that 8 bits are transmitted for each character. Only upper case letters, numeric digits and IA-5 “space” are used. The rightmost character is transmitted first. For a three-character airport ID, the rightmost (first transmitted) character shall be IA-5 “space”.

Runway number: the approach runway number.

Coding: 1 to 36 = runway number

Note.— For heliport and point-in-space operations, the runway number value is the integer nearest to one tenth of the final approach course, except when that integer is zero, in which case the runway is 36.

Runway letter: the one-letter designator used, as necessary, to differentiate between parallel runways.

Coding: 0 = no letter

1 = R (right)

2 = C (centre)

3 = L (left)

Approach performance designator: the general information about the approach design.

Coding: 0 = APV

1 = Category I

2 = reserved for Category II

3 = reserved for Category III

4 to 7 = spare

Note.— Some airborne equipment designed for Category I performance is insensitive to the value of the APD. It is intended that airborne equipment designed for Category I performance accepts APD values of at least 1-4 as valid to accommodate future extensions to higher performance types using the same FAS data block.

Route indicator: the one-letter identifier used to differentiate between multiple approaches to the same runway end.

Coding: The letter is coded using bits b₁ through b₅ of its IA-5 representation. Bit b₁ is transmitted first. Only upper case letters, excluding “I” and “O”, or IA-5 “space” are used.

Reference path data selector (RPDS): the numeric identifier that is used to select the FAS data block (desired approach).

Note.— The RPDS for a given FAS data block is different from every other RPDS and every reference station data selector (RSDS) broadcast on the same frequency by every GBAS within the broadcast region.

Reference path identifier (RPI): the three or four alphanumeric characters used to uniquely designate the reference path.

Coding: Each character is coded using bits b₁ through b₆ of its IA-5 representation. For each character, b₁ is transmitted first, and 2 zero bits are appended after b₆ so that 8 bits are transmitted for each character. Only upper case letters, numeric digits and IA-5 “space” are used. The rightmost character is transmitted first. For a three-character reference path identifier, the rightmost (first transmitted) character shall be IA-5 “space”.

Note.— The LTP/FTP is a point over which the FAS path passes at a relative height specified by the TCH. LTP is normally located at the intersection of the runway centreline and the threshold.

LTP/FTP latitude: the latitude of the LTP/FTP point in arc seconds.

Coding: Positive value denotes north latitude.
Negative value denotes south latitude.

LTP/FTP longitude: the longitude of the LTP/FTP point in arc seconds.

Coding: Positive value denotes east longitude.
Negative value denotes west longitude.

LTP/FTP height: the height of the LTP/FTP above the WGS-84 ellipsoid.

Coding: This field is coded as an unsigned fixed-point number with an offset of –512 metres. A value of zero in this field places the LTP/FTP 512 metres below the earth ellipsoid.

Note.— The FPAP is a point at the same height as the LTP/FTP that is used to define the alignment of the approach. The origin of angular deviations in the lateral direction is defined to be 305 metres (1 000 ft) beyond the FPAP along the lateral FAS path. For an approach aligned with the runway, the FPAP is at or beyond the stop end of the runway.

ΔFPAP latitude: the difference of latitude of the runway FPAP from the LTP/FTP in arc seconds.

Coding: Positive value denotes the FPAP latitude north of LTP/FTP latitude.
Negative value denotes the FPAP latitude south of the LTP/FTP latitude.

ΔFPAP longitude: the difference of longitude of the runway FPAP from the LTP/FTP in arc seconds.

Coding: Positive value indicates the FPAP longitude east of LTP/FTP longitude.
Negative value indicates the FPAP longitude west of LTP/FTP longitude.

Approach TCH: the height of the FAS path above the LTP/FTP defined in either feet or metres as indicated by the TCH units selector.

Approach TCH units selector: the units used to describe the TCH.

Coding: 0 = feet
1 = metres

Glide path angle (GPA): the angle of the FAS path with respect to the horizontal plane tangent to the WGS-84 ellipsoid at the LTP/FTP.

Course width: the lateral displacement from the path defined by the FAS at the LTP/FTP at which full-scale deflection of a course deviation indicator is attained.

Coding: This field is coded as an unsigned fixed-point number with an offset of 80 metres. A value of zero in this field indicates a course width of 80 metres at the LTP/FTP.

Length offset: the distance from the stop end of the runway to the FPAP.

Coding: 1111 1111 = not provided

Final approach segment CRC: the 32-bit CRC appended to the end of each FAS data block in order to ensure approach data integrity. The 32-bit final approach segment CRC shall be calculated in accordance with 3.9. The length of the CRC code shall be $k = 32$ bits.

The CRC generator polynomial shall be:

$$G(x) = x^{32} + x^{31} + x^{24} + x^{22} + x^{16} + x^{14} + x^8 + x^7 + x^5 + x^3 + x + 1$$

The CRC information field, $M(x)$, shall be:

$$M(x) = m_{272}x^{272} + m_{271}x^{271} + m_{270}x^{270} + \dots + m_1x^0$$

$M(x)$ shall be formed from all bits of the associated FAS data block, excluding the CRC. Bits shall be arranged in the order transmitted, such that m_1 corresponds to the LSB of the operation type field, and m_{272} corresponds to the MSB of the length offset field. The CRC shall be ordered such that r_1 is the LSB and r_{32} is the MSB.

3.6.4.6 *Type 5 message — predicted ranging source availability*. When used, the Type 5 message shall contain rising and setting information for the currently visible or soon to be visible ranging sources. Predicted ranging source availability parameters shall be as follows:

Modified Z-count: indicates the time of applicability of the parameters in this message.

Coding: Same as modified Z-count field in Type 1 message (3.6.4.2).

Number of impacted sources: the number of sources for which duration information applicable to all approaches is provided.

Coding: 0 = Only specified obstructed approaches have limitations.
1 to 31 = The number of ranging sources impacted.

Ranging source ID: as for Type 1 message (3.6.4.2).

Source availability sense: indicates whether the ranging source will become available or cease to be available.

Coding: 0 = Differential corrections will soon cease to be provided for the associated ranging source.
1 = Differential corrections will soon start to be provided for the associated ranging source.

Source availability duration: the predicted minimum ranging source availability duration relative to the modified Z-count.

Coding: 111 1111 = The duration is greater than or equal to 1 270 seconds.

Number of obstructed approaches: the number of approaches for which the corrections will be reduced due to approach unique constellation masking.

Reference path data selector: an indication of the FAS data block to which the source availability data applies (3.6.4.5.1).

Number of impacted sources for this approach: the number of sources for which duration information applicable only to this approach is provided.

3.6.4.7 TYPE 6 MESSAGE

Note.— Type 6 message is reserved for future use to provide the information required for Category II/III precision approaches.

3.6.4.8 TYPE 7 MESSAGE

Note.— Type 7 message is reserved for national applications.

3.6.4.9 TYPE 8 MESSAGE

Note.— Type 8 message is reserved for local and regional test applications.

3.6.4.10 TYPE 101 MESSAGE — GRAS PSEUDO-RANGE CORRECTIONS

3.6.4.10.1 The Type 101 message shall provide the differential correction data for individual GNSS ranging sources (Table B-70A). The message shall contain three sections:

- a) message information (time of validity, additional message flag, number of measurements and the measurement type);
- b) low-frequency information (ephemeris decorrelation parameter, satellite ephemeris CRC and satellite availability information); and
- c) satellite data measurement blocks.

3.6.4.10.2 Each Type 101 message shall include ephemeris decorrelation parameter, ephemeris CRC and source availability duration parameters for one satellite ranging source. The ephemeris decorrelation parameter, ephemeris CRC and source availability duration shall apply to the first ranging source in the message.

3.6.4.10.3 Pseudo-range correction parameters shall be as follows:

Modified Z-count: as defined in 3.6.4.2.3.

Additional message flag: as defined in 3.6.4.2.3 except applicable to Type 101 messages.

Number of measurements: as defined in 3.6.4.2.3.

Measurement type: as defined in 3.6.4.2.3.

Ephemeris decorrelation parameter (P): as defined in 3.6.4.2.3.

Ephemeris CRC: as defined in 3.6.4.2.3.

Source availability duration: as defined in 3.6.4.2.3.

Number of B parameters: an indication of whether the B parameters are included in the measurement block for each ranging source.

Coding: 0 = B parameters are not included
1 = 4 B parameters per measurement block

3.6.4.10.4 The measurement block parameters shall be as follows:

Ranging source ID: as defined in 3.6.4.2.4.

Issue of data (IOD): as defined in 3.6.4.2.4.

Pseudo-range correction (PRC): as defined in 3.6.4.2.4.

Range rate correction (RRC): as defined in 3.6.4.2.4.

σ_{pr_gnd} : as defined in 3.6.4.2.4, with the exception of the range of values and resolution.

B1 through B4: as defined in 3.6.4.2.4.

Note.— Inclusion of the B parameters in the measurement block is optional for type 101 messages.

3.6.5 DEFINITIONS OF PROTOCOLS FOR DATA APPLICATION

Note.— This section defines the inter-relationships of the data broadcast message parameters. It provides definitions of parameters that are not transmitted, but are used by either or both non-aircraft and aircraft elements, and that define terms applied to determine the navigation solution and its integrity.

3.6.5.1 *Measured and carrier smoothed pseudo-range.* The broadcast correction is applicable to carrier smoothed code pseudo-range measurements that have not had the satellite broadcast troposphere and ionosphere corrections applied to them. The carrier smoothing is defined by the following filter:

$$P_{CSCn} = \alpha P + 1 - \alpha P_{CSCn-1} + \frac{\lambda}{2\pi} (\phi_n - \phi_{n-1})$$

Where

P_{CSCn} = the smoothed pseudo-range;
 P_{CSCn-1} = the previous smoothed pseudo-range;
 P = the raw pseudo-range measurement where the raw pseudo-range measurements are obtained from a

carrier driven code loop, first order or higher and with a one-sided noise bandwidth greater than or equal to 0.125 Hz;

λ = the L1 wavelength;
 ϕ_n = the carrier phase;
 ϕ_{n-1} = the previous carrier phase; and
 α = the filter weighting function equal to the sample interval divided by the time constant of 100 seconds, except as specified in 3.6.8.3.5.1 for airborne equipment.

3.6.5.2 *Corrected pseudo-range.* The corrected pseudo-range for a given satellite at time t is:

$$PR_{\text{corrected}} = P_{\text{CSC}} + \text{PRC} + \text{RRC} \times (t - \text{tz-count}) + \text{TC} + c \times (t_{\text{sv}})_{\text{L1}}$$

where

P_{CSC} = the smoothed pseudo-range (defined in 3.6.5.1);
 PRC = the pseudo-range correction (defined in 3.6.4.2);
 RRC = the pseudo-range correction rate (defined in 3.6.4.2);
 t = the current time;
 tz-count = the time of applicability derived from the modified Z-count (defined in 3.6.4.2);
 TC = the tropospheric correction (defined in 3.6.5.3); and
 c and $(t_{\text{sv}})_{\text{L1}}$ are as defined in 3.1.2.2 for GPS satellites.

3.6.5.3 *TROPOSPHERIC DELAY*

3.6.5.3.1 The tropospheric correction for a given satellite is:

$$\text{TC} = N_r h_0 \frac{10^{-6}}{0.002 \sin^2 E_{li}} e^{-\Delta h/h_0}$$

where

N_r = refractivity index from the Type 2 message (3.6.4.3);
 h = height of the aircraft above the GBAS reference point;

E_{li} = elevation angle of the i^{th} satellite; and
 h_0 = troposphere scale height from the Type 2 message.

3.6.5.3.2 The residual tropospheric uncertainty is:

$$\sigma_{\text{tropo}} = \sigma_n h_0 \frac{10^{-6}}{0.002 \sin^2 E_{li}} e^{-\Delta h/h_0}$$

Where σ_n = the refractivity uncertainty from the Type 2 message (3.6.4.3).

3.6.5.4 *Residual ionospheric uncertainty.* The residual ionospheric uncertainty for a given satellite is:

$$\sigma_{iono} = F_{pp} \times \sigma_{vert_iono_gradient} \times (X_{air} + 2 \times \tau \times V_{air})$$

where

- F_{pp} = the vertical-to-slant obliquity factor for a given satellite (3.5.5.5.2);
- $\sigma_{vert_iono_gradient}$ = (as defined in 3.6.4.3);
- X_{air} = the distance (slant range) in metres between current aircraft location and the GBAS reference point indicated in the Type 2 message;
- τ = 100 seconds (time constant used in 3.6.5.1); and
- V_{air} = the aircraft horizontal approach velocity (metres per second).

3.6.5.5 PROTECTION LEVELS

3.6.5.5.1 *Category I precision approach and APV.* The signal-in-space vertical and lateral protection levels (VPL and LPL) are upper confidence bounds on the error in the position relative to the GBAS reference point defined as:

$$VPL = \text{MAX}\{VPL_{H0}, VPL_{H1}\}$$

$$LPL = \text{MAX}\{LPL_{H0}, LPL_{H1}\}$$

3.6.5.5.1.1 Normal measurement conditions

3.6.5.5.1.1.1 The vertical protection level (VPL_{H0}) and lateral protection level (LPL_{H0}), assuming that normal measurement conditions (i.e. no faults) exist in all reference receivers and on all ranging sources, is calculated as:

$$VPL_{H0} = K_{ffmd} \sqrt{\sum_{i=1}^N s_{vert_i}^2 \sigma_i^2}$$

$$LPL_{H0} = K_{ffmd} \sqrt{\sum_{i=1}^N s_{lat_i}^2 \sigma_i^2}$$

where

- K_{ffmd} = the multiplier derived from the probability of fault-free missed detection;
- s_{vert_i} = $s_{v,i} + s_{x,i} \times \tan(GPA)$;
- s_{lat_i} = $s_{y,i}$;
- $s_{x,i}$ = the partial derivative of position error in the x-direction with respect to pseudo-range error on the i^{th} satellite;
- $s_{y,i}$ = the partial derivative of position error in the y-direction with respect to pseudo-range error on the i^{th} satellite;
- $s_{v,i}$ = the partial derivative of position error in the vertical direction with respect to pseudo-range error on the i^{th} satellite;

- GPA = the glidepath angle for the final approach path (3.6.4.5.1);
 N = the number of ranging sources used in the position solution; and
 i = the ranging source index for ranging sources used in the position solution.

Note.— The coordinate reference frame is defined such that x is along track positive forward, y is crosstrack positive left in the local level tangent plane and v is the positive up and orthogonal to x and y.

3.6.5.5.1.1.2 For a general-least-squares position solution, the projection matrix S is defined as:

$$S \equiv \begin{matrix} S_{x,1} & S_{x,2} & \dots & S_{x,N} \\ S_{y,1} & S_{y,2} & \dots & S_{y,N} \\ S_{v,1} & S_{v,2} & \dots & S_{v,N} \\ S_{t,1} & S_{t,2} & \dots & S_{t,N} \end{matrix} G^T W G^{-1} G^T W$$

where

$$G_i = [-\cos E_{li} \cos A_{zi} \quad -\cos E_{li} \sin A_{zi} \quad -\sin E_{li} \quad 1] = i^{\text{th}} \text{ row of } G; \text{ and}$$

$$W = \begin{matrix} \sigma_1^2 & 0 & \dots & 0 \\ 0 & \sigma_2^2 & \dots & 0 \\ \vdots & \vdots & \ddots & \vdots \\ 0 & 0 & \dots & \sigma_N^2 \end{matrix}$$

$$\text{where } \sigma_i^2 = \sigma_{\text{pr_gnd},i}^2 + \sigma_{\text{tropo},i}^2 + \sigma_{\text{pr_air},i}^2 + \sigma_{\text{iono},i}^2;$$

where

$$\sigma_{\text{pr_gnd},i} = \sigma_{\text{pr_gnd}} \text{ for the } i^{\text{th}} \text{ ranging source (3.6.4.2);}$$

$$\sigma = \text{the residual tropospheric uncertainty for the } i^{\text{th}} \text{ ranging source (3.6.5.3);}$$

$$\sigma = \text{the residual ionospheric delay (due to spatial decorrelation) uncertainty for the } i^{\text{th}} \text{ ranging source (3.6.5.4); and}$$

$$\sigma_{\text{pr_gnd},i} = \sigma_{\text{receiver}}^2 E_{li} \sigma_{\text{multipath}}^2 E_{li}, \text{ the standard deviation of the aircraft contribution to the corrected pseudo-range error for the } i^{\text{th}} \text{ ranging source. The total aircraft contribution includes the receiver contribution (3.6.8.2.1) and a standard allowance for airframe multipath;}$$

where

$$\sigma_{\text{multipath}}(E_{li}) = 0.13 + 0.53e^{-E_{li}/10 \text{ deg}}, \text{ the standard model for the contribution of airframe multipath (in metres);}$$

$$E_{li} = \text{the elevation angle for the } i^{\text{th}} \text{ ranging source (in degrees); and}$$

$$A_{zi} = \text{the azimuth for the } i^{\text{th}} \text{ ranging source taken counterclockwise for the x axis (in degrees).}$$

Note.— To improve readability, the subscript i was omitted from the projection matrix's equation.

3.6.5.5.1.2 *Faulted measurement conditions.* When the Type 101 message is broadcast without B parameter blocks, the values for VPL_{H1} and LPL_{H1} are defined as zero. Otherwise, the vertical protection level (VPL_{H1}) and lateral protection level (LPL_{H1}), assuming that a latent fault exists in one, and only one reference receiver, are:

$$VPL_{H1} = \max [VPL_j]$$

$$LPL_{H1} = \max [LPL_j]$$

Where VPL_j and LPL_j for j = 1 to 4 are

$$VPL_j = |B_{\text{vert}j}| + K_{\text{md}} \sigma_{\text{vert},H1} \text{ and}$$

$LPL_j = |B_lat_j| + K_{md} \sigma_{lat,H1}$
and

$B_vert_j = \sum_{i=1}^N 1(s_vert_{i=j} \times B_{i,j}); B_lat_j$

$B_lat_j = \sum_{i=1}^N 1(s_lat_i \times B_{i,j});$

$B_{i,j}$ = the broadcast differences between the broadcast pseudo-range corrections and the corrections obtained excluding the j^{th} reference receiver measurement for the i^{th} ranging source;

K_{md} = the multiplier derived from the probability of missed detection given that the ground subsystem is faulted;

$$\sigma_{vert,H1}^2 = \sum_{i=1}^N s_vert \sigma_{H1}^2 ;$$

$$\sigma_{lat,H1}^2 = \sum_{i=1}^N s_lat \sigma_{H1}^2 ;$$

$$\sigma_{H1}^2 = \frac{M_i}{U_i} (\sigma_{pr_gnd,i}^2 + \sigma_{pr_air,i}^2 + \sigma_{tropo,i}^2 + \sigma_{iono,i}^2);$$

M_i = the number of reference receivers used to compute the pseudo-range corrections for the i^{th} ranging source (indicated by the B values); and

U_i = the number of reference receivers used to compute the pseudo-range corrections for the i^{th} ranging source, excluding the j^{th} reference receiver.

Note.— A latent fault includes any erroneous measurement(s) that is not immediately detected by the ground subsystem, such that the broadcast data are affected and there is an induced position error in the aircraft subsystem.

3.6.5.5.1.3 *Definition of K multipliers for Category I precision approach and APV.* The multipliers are given in Table B-67

Table B-67. K-multipliers for Category I precision approach and APV

Multiplier	M_i			
	1 ^(Note)	2	3	4
K_{ffmd}	6.86	5.762	5.81	5.847
K_{md}	Not used	2.935	2.898	2.878

Note.— For APV I approaches supported by Type 101 messages broadcast without the B parameter block

3.6.5.5.2 *GBAS positioning service.* The signal-in-space horizontal protection level is an upper confidence bound on the horizontal error in the position relative to the GBAS reference point defined as:

$$HPL = \text{MAX}\{HPL_{H0}, HPL_{H1}\}$$

3.6.5.5.2.1 *Normal measurements conditions.* The horizontal protection level (HPL_{H0}), assuming that normal measurement conditions (i.e. no faults) exist in all reference receivers and on all ranging sources, is calculated as:

$$HPL_{H0} = K_{\text{ffmd, POS}}^d d_{\text{major}}^d$$

where:

$$d_{\text{major}}^d = \sqrt{\frac{d_x^2}{2} + \frac{d_y^2}{2} + \frac{d_{xy}^2}{2}}$$

$$d_x^2 = \sum_{i=1}^N s_{x,i}^2 \sigma_i^2$$

$$d_y^2 = \sum_{i=1}^N s_{y,i}^2 \sigma_i^2$$

$$d_{xy}^2 = \sum_{i=1}^N s_{x,i} s_{y,i} \sigma_i^2$$

- $s_{x,i}$ = the partial derivative of position error in the x-direction with respect to pseudo-range error on the i^{th} satellite
- $s_{y,i}$ = the partial derivative of position error in the y-direction with respect to pseudo-range error on the i^{th} satellite
- $K_{\text{ffmd, POS}}^d$ = the multiplier derived from the probability of fault-free missed detection
- N = the number of ranging sources used in the position solution
- i = the ranging source index for ranging sources used in the position solution
- σ_i = the pseudo-range error term as defined in 3.6.5.5.1.1

Note.— For the GBAS positioning service, the x and y axes define an arbitrary orthogonal basis in the horizontal plane.

3.6.5.5.2.2 *Faulted measurement conditions.* When the Type 101 message is broadcast without B parameter blocks, the value for HPL_{H1} is defined as zero. Otherwise, the horizontal protection level (HPL_{H1}), assuming that a latent fault exists in one and only one reference receiver, is:

$$HPL_{H1} = \text{max} [HPL_j]$$

where HPL_j for $j = 1$ to 4 is:

$$HPL_j = |B_{\text{horzj}}| + K_{\text{md_POS}}^d d_{\text{major,H1}}^d$$

and

$$B_{\text{horzj}} = \sqrt{\sum_{i=1}^N s_{x,i}^2 B_{ij}^2 + \sum_{i=1}^N s_{y,i}^2 B_{ij}^2}$$

B_{ij} = the broadcast differences between the broadcast pseudo-range corrections and the corrections obtained

excluding the j^{th} reference receiver measurement for the i^{th} ranging source.

$K_{\text{md_POS}}$ = the multiplier derived from the probability of missed detection given that the ground subsystem is faulted.

$$d_{\text{major,H1}} = \frac{d_{\text{H1x}} \quad d_{\text{H1y}}}{2} \quad \frac{d_{\text{H1x}} \quad d_{\text{H1y}}}{2} \quad d_{\text{H1xy}}$$

$$d_{\text{H1x}}^2 = \sum_{i=1}^N s_{x,i}^2 \sigma_{\text{H1}}^2$$

$$d_{\text{H1y}}^2 = \sum_{i=1}^N s_{y,i}^2 \sigma_{\text{H1}}^2$$

$$d_{\text{H1xy}} = \sum_{i=1}^N s_{x,i} s_{y,i} \sigma_{\text{H1}}^2$$

Note.— For the GBAS positioning service, the x and y axes define an arbitrary orthogonal basis in the horizontal plane

$$\sigma_{\text{H1}}^2 = \frac{M_i}{U_i} \left(\sigma_{\text{pr}^2\text{-gnd},i}^2 + \sigma_{\text{pr}^2\text{-air},i}^2 + \sigma_{\text{tropo}^2,i}^2 + \sigma_{\text{iono}^2,i}^2 \right)$$

M_i = the number of reference receivers used to compute the pseudo-range corrections for the i^{th} ranging source (indicated by the B values).

U_i = the number of reference receivers used to compute the pseudo-range corrections for the i^{th} ranging source, excluding the j^{th} reference receiver.

Note.— A latent fault includes any erroneous measurement(s) that is not immediately detected by the ground subsystem, such that the broadcast data are affected and there is an induced position error in the aircraft subsystem.

3.6.5.5.2.3 *Definition of K multipliers for GBAS positioning service.* The multiplier $K_{\text{ffmd_POS}}$ is equal to 10.0 and the multiplier $K_{\text{md_POS}}$, is equal to 5.3.

3.6.5.6 ALERT LIMITS

Note.— Guidance concerning the calculation of alert limits, including approaches associated with channel numbers 40 000 to 99 999, is provided in Attachment D, 7.13.

3.6.5.6.1 *Category I precision approach alert limits.* The alert limits are defined in Tables B-68 and B-69. For aircraft positions at which the lateral deviation exceeds twice the deviation at which full-scale lateral deflection of a course deviation indicator is achieved, or vertical deviation exceeds twice the deviation at which full-scale fly-down deflection of a course deviation indicator is achieved, both the lateral and vertical alert limits are set to the maximum values given in the tables.

3.6.5.6.2 *APV alert limits.* The alert limits are equal to the FASLAL and FASVAL for approaches with channel numbers in the range of 20 001 to 39 999. For approaches with channel numbers in the range 40 000 to 99 999, the alert limits are stored in the on-board database.

3.6.5.7 *Channel number.* Each GBAS approach transmitted from the ground subsystem is associated with a channel number in the range of 20 001 to 39 999. If provided, the GBAS positioning service is associated with a separate channel number in the range of 20 001 to 39 999. The channel number is given by:

$$\text{Channel number} = 20\,000 + 40(F - 108.0) + 411(S)$$

where

- F = the data broadcast frequency (MHz)
- S = RPDS or RSDS

and

- RPDS = the reference path data selector for the FAS data block (as defined in 3.6.4.5.1)
- RSDS = the reference station data selector for the GBAS ground subsystem (as defined in 3.6.4.3.1)

Table B-68. Category I lateral alert limit

Horizontal distance of aircraft position from the LTP/FTP as translated along the final approach path (metres)	Lateral alert limit (metres)
291 < D ≤ 873	FASLAL
873 < D ≤ 7500	0.0044D (m) + FASLAL – 3.85
D > 7500	FASLAL + 29.15

Table B-69. Category I vertical alert limit

Height above LTP/FTP of aircraft position translated onto the final approach path (feet)	Vertical alert limit (metres)
100 < H ≤ 200	FASVAL
200 < H ≤ 1340	0.02925H (ft) + FASVAL – 5.85
H > 1340	FASVAL + 33.35

For channel numbers transmitted in the additional data block 2 of Type 2 message (as defined in 3.6.4.3.2.1), only RSDS are used.

Note 1.— When the FAS is not broadcast for an APV, the GBAS approach is associated with a channel number in the range 40 000 to 99 999.

Note 2.— Guidance material concerning channel number selection is provided in Attachment D, 7.7.

3.6.5.8 *EPHEMERIS ERROR POSITION BOUND*

Note.— Ephemeris error position bounds are computed only for core satellite constellation ranging sources used in the position solution (*j* index) and not for other types of ranging sources (SBAS satellites or pseudolites) that are not subject to undetected ephemeris failures. However, the calculations of these position bounds use information from all ranging sources used in the position solution (*i* index).

3.6.5.8.1 *Category I precision approach and APV.* The vertical and lateral ephemeris error position bounds are defined as:

$$VEB = \text{MAX}\{VEB_j\}$$

$$LEB = \text{MAX}\{LEB_j\}$$

The vertical and lateral ephemeris error position bounds for the *j*th core satellite constellation ranging source used in the position solution are given by:

$$VEB_j = s_{\text{vert}j} x_{\text{air}j} P_j K_{\text{md}_e,j} \sqrt{\sum_{i=1}^N s_{\text{vert}i}^2 \sigma_i^2}$$

$$LEB_j = s_{\text{lat}j} x_{\text{air}j} P_j K_{\text{md}_e,j} \sqrt{\sum_{i=1}^N s_{\text{lat}i}^2 \sigma_i^2}$$

Where:

s_{vert_i or j} is defined in 3.6.5.5.1.1

s_{lat_i or j} is defined in 3.6.5.5.1.1

x_{air} is defined in 3.6.5.4

N is the number of ranging sources used in the position

σ_i solution is defined in 3.6.5.5.1.1

P_j is the broadcast ephemeris decorrelation parameter for the *j*th ranging source

K_{md_e,j} is the broadcast ephemeris missed detection multiplier for Category I precision approach and APV associated with the satellite constellation for the *j*th ranging source (*K_{md_e,GPS}* or *K_{md_e,GLONASS}*)

3.6.5.8.2 *GBAS positioning service.* The horizontal ephemeris error position bound is defined as:

$$HEB = \text{MAX}\{HEB_j\}$$

The horizontal ephemeris error position bound for the *j*th core satellite constellation ranging source used in the position solution is given by:

$$HEB_j = S_{horz,j}^2 + S_{x,j}^2 + S_{y,j}^2 + P_j K_{md_e_POS_major}$$

where:

$$S_{horz,j}^2 + S_{x,j}^2 + S_{y,j}^2$$

$S_{x,j}$ is as defined in 3.6.5.5.2.1

$S_{y,j}$ is as defined in 3.6.5.5.2.1

X_{air} is defined in 3.6.5.4

P_j is the broadcast ephemeris decorrelation parameter for the j^{th} ranging source

$K_{md_e_POS}$ is the broadcast ephemeris missed detection multiplier for the GBAS positioning service associated with the satellite constellation for the j^{th} ranging source ($K_{md_e_POS,GPS}$ or $K_{md_e_POS,GLONASS}$)

d_{major} is as defined in 3.6.5.5.2.1

3.6.6 MESSAGE TABLES

Each GBAS message shall be coded in accordance with the corresponding message format defined in Tables B-70 through B-73.

Note.— Message type structure is defined in 3.6.4.1

Table B-70. Type 1 pseudo-range corrections message

Data content	Bits used	Range of values	Resolution
Modified Z-count	14	0 to 1 199.9 s	0.1 s
Additional message flag	2	0 to 3	1
Number of measurements (N)	5	0 to 18	1
Measurement type	3	0 to 7	1
Ephemeris decorrelation parameter (P)	8	0 to 1.275×10^{-3} m/m	5×10^{-6} m/m
Ephemeris CRC	16	—	—
Source availability duration	8	0 to 2 540 s	10 s
For N measurement blocks			
Ranging source ID	8	1 to 255	1
Issue of data (IOD)	8	0 to 255	1
Pseudo-range correction (PRC)	16	± 327.67 m	0.01 m
Range rate correction (RRC)	16	± 32.767 m/s	0.001 m/s
σ_{pr_gnd}	8	0 to 5.08 m	0.02 m
B ₁	8	± 6.35 m	0.05 m
B ₂	8	± 6.35 m	0.05 m
B ₃	8	± 6.35 m	0.05 m
B ₄	8	± 6.35 m	0.05 m

Table B-70A. Type 101 GRAS pseudo-range corrections message

Data content	Bits used	Range of values	Resolution
--------------	-----------	-----------------	------------

Modified Z-count	14	0 to 1 199.9 s	0.1 s
Additional message flag	2	0 to 3	1
Number of measurements (N)	5	0 to 18	1
Measurement type	3	0 to 7	1
Ephemeris decorrelation parameter (P)	8	0 to 1.275×10^{-3} m/m	5×10^{-6} m/m
Ephemeris CRC	16	—	—
Source availability duration	8	0 to 2540 s	10 s
Number of B parameters	1	0 or 4	—
Spare	7	—	—
For N measurement blocks			
Ranging source ID	8	1 to 255	1
Issue of data (IOD)	8	0 to 255	1
Pseudo-range correction (PRC)	16	± 327.67 m	0.01 m
Range rate correction (RRC)	16	± 32.767 m/s	0.001 m/s
σ_{pr_gnd}	8	0 to 50.8 m	0.2 m
B parameter block (if provided)			
B ₁	8	± 25.4 m	0.2 m
B ₂	8	± 25.4 m	0.2 m
B ₃	8	± 25.4 m	0.2 m
B ₄	8	± 25.4 m	0.2 m

Table B-71A. Type 2 GBAS-related data message

Data content	Bits used	Range of values	Resolution
GBAS reference receivers	2	2 to 4	—
Ground accuracy designator letter	2	—	—
Spare	1	—	—
GBAS continuity/integrity designator	3	0 to 7	1
Local magnetic variation	11	$\pm 180^\circ$	0.25°
Spare	5	—	—
$\sigma_{vert\ iono\ gradient}$	8	0 to 25.5×10^{-6} m/m	0.1×10^{-6} m/m
Refractivity index	8	16 to 781	3
Scale height	8	0 to 25 500 m	100 m
Refractivity uncertainty	8	0 to 255	1
Latitude	32	$\pm 90.0^\circ$	0.0005 arcsec
Longitude	32	$\pm 180.0^\circ$	0.0005 arcsec
GBAS reference point height	24	$\pm 83\ 886.07$ m	0.01 m
Additional data block 1 (if provided)			
Reference station data selector	8	0 to 48	1
Maximum use distance (D_{max})	8	2 to 510 km	2 km
$K_{md\ e,POS,GPS}$	8	0 to 12.75	0.05
$K_{md\ e,GPS}$	8	0 to 12.75	0.05
$K_{md\ e,POS,GLONASS}$	8	0 to 12.75	0.05
$K_{md\ e,GLONASS}$	8	0 to 12.75	0.05
Additional data block 2 (if provided)			

Data content	Bits used	Range of values	Resolution
Additional data block length	8	2 to 255	1

Additional data block number	8	2 to 255	1
Additional data parameters	Variable	—	—

Table B-71B. Type 3 null message

Data content	Bits used	Range of values	Resolution
Filler	Variable (Note)	N/A	N/A

Table B-72. Type 4 FAS data message

Data content	Bits used	Range of values	Resolution
For N data sets			
Data set length	8	2 to 212	1 byte
FAS data block	304	—	—
FAS vertical alert limit/approach status	8		
(1) when associated approach performance designator indicates APV-I (APD coded as 0)		0 to 50.8 m	0.2 m
(2) when associated approach performance designator does not indicate APV-I (APD not coded as 0)		0 to 25.4 m	0.1 m
FAS lateral alert limit/approach status	8	0 to 50.8 m	0.2 m

Table B-73. Type 5 predicted ranging source availability message

Data content	Bits used	Range of values	Resolution
Modified Z-count	14	0 to 1 199.9 s	0.1 s
Spare	2	—	—
Number of impacted sources (N)	8	0 to 31	1
For N impacted sources			
Ranging source ID	8	1 to 255	1
Source availability sense	1	—	—
Source availability duration	7	0 to 1 270 s	10 s
Number of obstructed approaches (A)	8	0 to 255	1
For A obstructed approaches			
Reference path data selector	8	0 to 48	—
Number of impacted sources for this approach (N _A)	8	1 to 31	1

For N_A impacted ranging sources for this approach

Ranging source ID	8	1 to 255	1
Source availability sense	1	—	—
Source availability duration	7	0 to 1 270 s	10 s

3.6.7 NON-AIRCRAFT ELEMENTS

3.6.7.1 PERFORMANCE

3.6.7.1.1 Accuracy

3.6.7.1.1.1 The root-mean-square (RMS) (1 sigma) of the ground subsystem contribution to the corrected pseudo-range accuracy for GPS and GLONASS satellites shall be:

$$\text{RMS}_{\text{pr_gnd}} = \sqrt{a_0 + a_1 e^{-\theta_n / \theta_0} + a_2^2}$$

where

- M = the number of GNSS reference receivers, as indicated in the Type 2 message parameter (3.6.4.3), or, when this parameter is coded to indicate “not applicable”, the value of M is defined as 1;
- n = nth ranging source;
- θ_n = elevation angle for the nth ranging source; and
- a₀, a₁, a₂, and θ₀ = parameters defined in Tables B-74 and B-75 for each of the defined ground accuracy designators (GADs).

Note 1.— The GBAS ground subsystem accuracy requirement is determined by the GAD letter and the number of installed reference receivers.

Note 2.— The ground subsystem contribution to the corrected pseudo-range error specified by the curves defined in Tables B-74 and B-75 and the contribution to the SBAS satellites do not include aircraft noise and aircraft multipath.

Table B-74. GBAS — GPS accuracy requirement parameters

Ground accuracy designator letter	θ _n (degrees)	a ₀ (metres)	a ₁ (metres)	θ ₀ (degrees)	a ₂ (metres)
A	≥ 5	0.5	1.65	14.3	0.08

B	≥ 5	0.16	1.07	15.5	0.08
C	> 35	0.15	0.84	15.5	0.04
	5 to 35	0.24	0	—	0.04

Table B-75. GBAS — GLONASS accuracy requirement parameters

Ground accuracy designator letter	θ_n (degrees)	a_0 (metres)	a_1 (metres)	θ_0 (degrees)	a_2 (metres)
A	≥ 5	1.58	5.18	14.3	0.078
B	≥ 5	0.3	2.12	15.5	0.078
C	> 35	0.3	1.68	15.5	0.042
	5 to 35	0.48	0	—	0.042

3.6.7.1.1.2 The RMS of the ground subsystem contribution to the corrected pseudo-range accuracy for SBAS satellites shall be:

$$\text{RMS}_{\text{pr_gnd}} = \frac{1.8}{\sqrt{M}} \text{ metres}$$

where M is as defined in 3.6.7.1.1.1.

Note.— GAD classifications for SBAS ranging sources are under development

3.6.7.1.2 Integrity

3.6.7.1.2.1 GBAS ground subsystem integrity risk

3.6.7.1.2.1.1 *Category I precision approach and APV.* For a GBAS ground subsystem that provides the Category I precision approach or APV, the integrity risk shall be less than 1.5×10^{-7} per approach.

Note 1.— The integrity risk assigned to the GBAS ground subsystem is a subset of the GBAS signal-in-space integrity risk, where the protection level integrity risk (3.6.7.1.2.2.1) has been excluded and the effects of all other GBAS, SBAS and core satellite constellations failures are included. The GBAS ground subsystem integrity risk includes the integrity risk of satellite signal monitoring required in 3.6.7.2.6 and the integrity risk associated with the monitoring in 3.6.7.3.

Note 2.— GBAS signal-in-space integrity risk is defined as the probability that the ground subsystem provides information which when processed by a fault-free receiver, using any GBAS data that could be used by the aircraft, results in an out-of-tolerance lateral or vertical relative position error without annunciation for a period longer than the maximum time-to-alert. An out-of-tolerance lateral or vertical relative position error is defined as an error that exceeds the Category I precision approach or APV protection level and, if additional data block 1 is broadcast, the ephemeris error position bound.

3.6.7.1.2.1.1.1 The GBAS ground subsystem maximum time-to-alert shall be less than or equal to 3 seconds when Type 1 messages are broadcast.

Note.— The time-to-alert above is the time between the onset of the out-of-tolerance lateral or vertical relative position error and the transmission of the last bit of the message that contains the integrity data that reflects the condition.

3.6.7.1.2.1.1.2 The GBAS ground subsystem maximum time-to-alert shall be less than or equal to 5.5 seconds when Type 101 messages are broadcast.

3.6.7.1.2.1.1.3 For Category I precision approach, the value FASLAL for each FAS block, as defined in the FAS lateral alert limit field of the Type 4 message shall be no greater than 40 metres, and the value FASVAL for each FAS block, as defined in the FAS vertical alert limit field of the Type 4 message, shall be no greater than 10 metres.

3.6.7.1.2.1.1.4 For APV, the value FASLAL and FASVAL shall be no greater than the lateral and vertical alert limits given in Annex 10, Volume I, 3.7.2.4.

3.6.7.1.2.1.2 *GBAS positioning service.* For GBAS ground subsystem that provides the GBAS positioning service, integrity risk shall be less than 9.9×10^{-8} per hour.

Note 1.— The integrity risk assigned to the GBAS ground subsystem is a subset of the GBAS signal-in-space integrity risk, where the protection level integrity risk (3.6.7.1.2.2.2) has been excluded and the effects of all other GBAS, SBAS and core satellite constellations failures are included. The GBAS ground subsystem integrity risk includes the integrity risk of satellite signal monitoring required in 3.6.7.2.6 and the integrity risk associated with the monitoring in 3.6.7.3.

Note 2.— GBAS signal-in-space integrity risk is defined as the probability that the ground subsystem provides information which when processed by a fault-free receiver, using any GBAS data that could be used by the aircraft, results in an out-of-tolerance horizontal relative position error without annunciation for a period longer than the maximum time-to-alert. An out-of-tolerance horizontal relative position error is defined as an error that exceeds both the horizontal protection level and the horizontal ephemeris error position bound.

3.6.7.1.2.1.2.1 The GBAS ground subsystem maximum time-to-alert shall be less than or equal to 3 seconds when Type 1 messages are broadcast and less than or equal to 5.5 seconds when Type 101 messages are broadcast.

Note.— The time-to-alert above is the time between the onset of the out-of-tolerance horizontal relative position error and the transmission of the last bit of the message that contains the integrity data that reflects the condition.

3.6.7.1.2.2 *Protection level integrity risk*

3.6.7.1.2.2.1 For a GBAS ground subsystem that provides the Category I precision approach or APV, the protection level integrity risk shall be less than 5×10^{-8} per approach.

Note.— The Category I precision approach and APV protection level integrity risk is the integrity risk due to undetected errors in position relative to the GBAS reference point greater than the associated protection levels under the two following conditions:

- a) *normal measurement conditions defined in 3.6.5.5.1.1; and*
- b) *faulted measurement conditions defined in 3.6.5.5.1.2.*

3.6.7.1.2.2.2 For a GBAS ground subsystem that provides the positioning service, protection level integrity risk shall be less than 10^{-9} per hour.

Note.— The GBAS positioning service protection level integrity risk is the integrity risk due to undetected errors in the horizontal position relative to the GBAS reference point greater than the GBAS positioning service protection level under the two following conditions:

- a) *normal measurement conditions defined in 3.6.5.5.2.1; and*
- faulted measurement conditions defined in 3.6.5.5.2.2.*

3.6.7.1.3 Continuity of service

3.6.7.1.3.1 Continuity of service for Category I precision approach and APV. The GBAS ground subsystem continuity of service shall be greater than or equal to $1 - 8.0 \times 10^{-6}$ per 15 seconds.

Note.— The GBAS ground subsystem continuity of service is the average probability per 15-second period that the VHF data broadcast transmits data in tolerance, VHF data broadcast field strength is within the specified range and the protection levels are lower than the alert limits, including configuration changes that occur due to the space segment. This continuity of service requirement is the entire allocation of the signal-in-space continuity requirement from Chapter 3, Table 3.7.2.4-1, and therefore all continuity risks included in that requirement must be accounted for by the ground subsystem provider.

3.6.7.1.3.2 Continuity of service for positioning service

Note.— For GBAS ground subsystems that provide the GBAS positioning service, there may be additional continuity requirements depending on the intended operations.

3.6.7.2 FUNCTIONAL REQUIREMENTS

3.6.7.2.1 General

3.6.7.2.1.1 Data broadcast rates

3.6.7.2.1.1.1 A GBAS ground subsystem that supports Category I precision approach or APV-II shall broadcast Type 1 messages. A GBAS ground subsystem that does not support Category I precision approach or APV-II shall broadcast either Type 1 or Type 101 messages. A GBAS ground subsystem shall not broadcast both Type 1 and Type 101 messages.

Note.— Guidance material concerning usage of the Type 101 message is provided in Attachment D, 7.18.

3.6.7.2.1.1.2 Each GBAS ground subsystem shall broadcast Type 2 messages.

3.6.7.2.1.1.3 Each GBAS ground subsystem shall broadcast FAS blocks in Type 4 messages for all Category I precision approaches supported by that GBAS ground subsystem. If a GBAS ground subsystem supports APV and does not broadcast FAS blocks for the corresponding approaches, it shall broadcast additional data block 1 in the Type 2 message.

Note.— FAS blocks for APV procedures may be held within a database on board the aircraft. Broadcasting additional data block 1 allows the airborne receiver to select the GBAS ground subsystem that supports the approach procedures in the airborne database. FAS blocks may also be broadcast to support operations by aircraft without an airborne database. These procedures use different channel numbers as described in Attachment D, 7.7.

3.6.7.2.1.1.4 When the Type 5 message is used, the ground subsystem shall broadcast the Type 5 message at a rate in accordance with Table B-76.

Note.— When the standard 5 degree mask is not adequate to describe satellite visibility at either the ground subsystem antennas or at an aircraft during a specific approach, the Type 5 message may be used to broadcast additional information to the aircraft.

3.6.7.2.1.1.5 Data broadcast rates. For all message types required to be broadcast, messages meeting the field strength requirements of Chapter 3, 3.7.3.5.4.4.1.2 and 3.7.3.5.4.4.2.2 and the minimum rates shown in Table B-76 shall be provided at every point within the coverage. The total message broadcast rates from all antenna systems of the ground subsystem combined shall not exceed the maximum rates shown in Table B-76.

Note.— Guidance material concerning the use of multiple antenna systems is provided in Attachment D, 7.12.4.

Table B-76. GBAS VHF data broadcast rates

Message type	Minimum broadcast rate	Maximum broadcast rate
1 or 101	For each measurement type: All measurement blocks once per frame (Note)	For each measurement type: All measurement blocks once per slot
2	Once per 20 consecutive frames	Once per frame
4	All FAS blocks once per 20 consecutive frames	All FAS blocks once per frame
5	All impacted sources once per 20 consecutive frames	All impacted sources once per 5 consecutive frames

Note.— One Type 1 or Type 101 message or two Type 1 or Type 101 messages that are linked using the additional message flag described in 3.6.4.2.

3.6.7.2.1.2 *Message block identifier.* The MBI shall be set to either normal or test according to the coding given in 3.6.3.4.1.

3.6.7.2.1.3 *VDB authentication*

Note.— This section is reserved for forward compatibility with future authentication functions.

3.6.7.2.2 *Pseudo-range corrections*

3.6.7.2.2.1 *Message latency.* The time between the time indicated by the modified Z-count and the last bit of the broadcast Type 1 or Type 101 message shall not exceed 0.5 seconds.

3.6.7.2.2.2 *Low-frequency data.* Except during an ephemeris change, the first ranging source in the message shall sequence so that the ephemeris decorrelation parameter, ephemeris CRC and source availability duration for each core satellite constellation’s ranging source are transmitted at least once every 10 seconds. During an ephemeris change, the first ranging source shall sequence so that the ephemeris decorrelation parameter, ephemeris CRC and source availability duration for each core satellite constellation’s ranging source are transmitted at least once every 27 seconds. When new ephemeris data are received from a core satellite constellation’s ranging source, the ground subsystem shall use the previous ephemeris data from each satellite until the new ephemeris data have been continuously received for at least 2 minutes but shall make a transition to the new ephemeris data before 3 minutes have passed. When this transition is made to using the new ephemeris data for a given ranging source, the ground subsystem shall broadcast the new ephemeris CRC for all occurrences of that ranging source in the low-frequency information of Type 1 or Type 101 message in the next 3 consecutive frames. For a given ranging source, the ground subsystem shall continue to transmit data corresponding to the previous ephemeris data until the new CRC ephemeris is transmitted in the low-frequency data of Type 1 or Type 101 message (see *Note*). If the ephemeris CRC changes and the IOD does not, the ground subsystem shall consider the ranging source invalid.

Note.— The delay before the ephemeris transition allow sufficient time for the aircraft subsystem to collect new ephemeris data.

3.6.7.2.2.1 **Recommendation.**— *The ephemeris decorrelation parameter and the ephemeris CRC for each core satellite constellation's ranging source should be broadcast as frequently as possible.*

3.6.7.2.2.3 *Broadcast pseudo-range correction.* Each broadcast pseudo-range correction shall be determined by combining the pseudo-range correction estimates for the relevant ranging source calculated from each of the reference receivers. For each satellite, the measurements used in this combination shall be obtained from the same ephemeris data. The corrections shall be based on smoothed code pseudo-range measurements for each satellite using the carrier measurement from a smoothing filter in accordance with 3.6.5.1.

3.6.7.2.2.4 *Broadcast signal-in-space integrity parameters.* The ground subsystem shall provide σ_{pr_gnd} and B parameters for each pseudo-range correction in Type 1 message such that the protection level integrity risk requirements defined in 3.6.7.1.2.2 are satisfied. The ground subsystem shall provide σ_{pr_gnd} and, if necessary, B parameters for each pseudo-range correction in Type 101 message such that the protection level integrity risk requirements defined in 3.6.7.1.2.2 are satisfied.

Note.— *Broadcast of the B parameters are optional for Type 101 messages. Guidance material regarding the B parameters in Type 101 messages is contained in Attachment D, 7.5.11.*

3.6.7.2.2.5 **Recommendation.**— *Reference receiver measurements should be monitored. Faulted measurements or failed reference receivers should not be used to compute the pseudo-range corrections.*

3.6.7.2.2.6 *Repeated transmission of Type 1 or Type 101 messages.* For a given measurement type and within a given frame, all broadcasts of Type 1 or Type 101 messages or linked pairs from all GBAS broadcast stations that share a common GBAS identification, shall have identical data content.

3.6.7.2.2.7 *Issue of data.* The GBAS ground subsystem shall set the IOD field in each ranging source measurement block to be the IOD value received from the ranging source that corresponds to the ephemeris data used to compute the pseudo-range correction.

3.6.7.2.2.8 *Application of signal error models.* Ionospheric and tropospheric corrections shall not be applied to the pseudo-ranges used to calculate the pseudo-range corrections.

3.6.7.2.2.9 *Linked pair of Type 1 or Type 101 messages.* If a linked pair of Type 1 or Type 101 messages is transmitted then,

- a) the two messages shall have the same modified Z-count;
- b) the minimum number of pseudo-range corrections in each message shall be one;
- c) the measurement block for a given satellite shall not be broadcast more than once in a linked pair of messages;
- d) the two messages shall be broadcast in different time slots; and
- e) the order of the B values in the two messages shall be the same.

3.6.7.2.2.10 *Modified Z-count update.* The modified Z-count for Type 1 or Type 101 messages of a given measurement type shall advance every frame.

3.6.7.2.2.11 *Ephemeris decorrelation parameters*

3.6.7.2.2.11.1 *Category I precision approach and APV.* For ground subsystems that broadcast the additional data block 1 in the Type 2 message, the ground subsystem shall broadcast the ephemeris decorrelation parameter for each core satellite constellation ranging source such that the ground subsystem integrity risk of 3.6.7.1.2.1.1 is met.

3.6.7.2.2.11.2 *GBAS positioning service.* For ground subsystems that provide the GBAS positioning service, the ground subsystem shall broadcast the ephemeris decorrelation parameter for each core satellite constellation's ranging source such that the ground subsystem integrity risk of 3.6.7.1.2.1.2 is met.

3.6.7.2.3 *GBAS-related data*

3.6.7.2.3.1 *Tropospheric delay parameters.* The ground subsystem shall broadcast a refractivity index, scale height, and refractivity uncertainty in a Type 2 message such that the protection level integrity risk requirements defined in 3.6.7.1.2.2 are satisfied.

3.6.7.2.3.2 *GCID indication.* If the ground subsystem meets the requirements of 3.6.7.1.2.1.1, 3.6.7.1.2.2.1 and 3.6.7.1.3.1 the GCID shall be set to 1 otherwise it shall be set to 7.

3.6.7.2.3.3 *GBAS reference antenna phase centre position accuracy.* For each GBAS reference receiver, the reference antenna phase centre position error shall be less than 8 cm relative to the GBAS reference point.

3.6.7.2.3.4 **Recommendation.**— *GBAS reference point survey accuracy. The survey error of the GBAS reference point, relative to WGS-84, should be less than 0.25 m vertical and 1 m horizontal.*

Note.— *Relevant guidance material is given in Attachment D, 7.16.*

3.6.7.2.3.5 *Ionospheric uncertainty estimate parameter.* The ground subsystem shall broadcast an ionospheric delay gradient parameter in the Type 2 message such that the protection level integrity risk requirements defined in 3.6.7.1.2.2 are satisfied.

3.6.7.2.3.6 For ground subsystems that provide the GBAS positioning service, the ground subsystem shall broadcast the ephemeris error position bound parameters using additional data block 1 in the Type 2 message.

3.6.7.2.3.7 **Recommendation.**— *All ground subsystems should broadcast the ephemeris error position bound parameters using additional data block 1 in the Type 2 message.*

3.6.7.2.3.8 For ground subsystems that broadcast additional data block 1 in the Type 2 message, the following requirements shall apply:

3.6.7.2.3.8.1 *Maximum use distance.* The ground subsystem shall provide the distance (D_{max}) from the GBAS reference point that defines a volume within which the ground subsystem integrity risk in 3.6.7.1.2.1 and the protection level integrity risk in 3.6.7.1.2.2 are met.

3.6.7.2.3.8.2 *Ephemeris missed detection parameters.* The ground subsystem shall broadcast the ephemeris missed detection parameters for each core satellite constellation such that the ground subsystem integrity risk of 3.6.7.1.2.1 is met.

3.6.7.2.3.8.3 *GBAS positioning service indication.* If the ground subsystem does not meet the requirements of 3.6.7.1.2.1.2 and 3.6.7.1.2.2.2, the ground subsystem shall indicate using the RSDS parameter that the GBAS positioning service is not provided.

3.6.7.2.3.9 If the VHF data broadcast is transmitted at more than one frequency within the GRAS service area, each GBAS broadcast station within the GRAS ground subsystem shall broadcast additional data blocks 1 and 2.

3.6.7.2.3.9.1 **Recommendation.**— *The VHF data broadcast should include additional data block 2 parameters to identify channel numbers and locations of adjacent and nearby GBAS broadcast stations within the GRAS ground subsystem.*

Note.— *This facilitates the transition from one GBAS broadcast station to other GBAS broadcast stations in the GRAS ground subsystem.*

3.6.7.2.4 Final approach segment data

3.6.7.2.4.1 *FAS data points accuracy.* The relative survey error between the FAS data points and the GBAS reference point shall be less than 0.25 metres vertical and 0.40 metres horizontal.

3.6.7.2.4.2 **Recommendation.**— *The final approach segment CRC should be assigned at the time of procedure design, and kept as an integral part of the FAS data block from that time onward.*

3.6.7.2.4.3 **Recommendation.**— *The GBAS should allow the capability to set the FASVAL and FASLAL for any FAS data block to “1111 1111” to limit the approach to lateral only or to indicate that the approach must not be used, respectively.*

3.6.7.2.5 Predicted ranging source availability data

Note.— *Ranging source availability data are optional for Category I and APV and may be required for possible future operations.*

3.6.7.2.6 *Integrity monitoring for GNSS ranging sources.* The ground subsystem shall monitor the satellite signals to detect conditions that will result in improper operation of differential processing for airborne receivers complying with the tracking constraints in Attachment D, 8.11. The ground subsystem shall use the strongest correlation peak in all receivers used to generate the pseudo-range corrections. The monitor time-to-alert shall comply with 3.6.7.1.2. The monitor action shall be to set σ_{pr_gnd} to the bit pattern “1111 1111” for the satellite or to exclude the satellite from the Type 1 or Type 101 message. The ground subsystem shall also detect conditions that cause more than one zero crossing for airborne receivers that use the Early-Late discriminator function as described in Attachment D, 8.11.

3.6.7.3 MONITORING

3.6.7.3.1 RF monitoring

3.6.7.3.1.1 *VHF data broadcast monitoring.* The data broadcast transmissions shall be monitored. The transmission of the data shall cease within 0.5 seconds in case of continuous disagreement during any 3-second period between the transmitted application data and the application data derived or stored by the monitoring system prior to transmission.

3.6.7.3.1.2 *TDMA slot monitoring.* The risk that the ground subsystem transmits a signal in an unassigned slot and fails to detect an out-of-slot transmission, which exceeds that allowed in 3.6.2.6, within 1 second, shall be less than 1×10^{-7} in any 30-second period. If out-of-slot transmissions are detected, the ground subsystem shall terminate all data broadcast transmissions within 0.5 seconds.

3.6.7.3.1.3 *VDB transmitter power monitor.* The probability that the horizontally or elliptically polarized signal’s transmitted power increases by more than 3 dB from the nominal power for more than 1 second shall be less than 2.0×10^{-7} in any 30-second period.

Note.— *The vertical component is only monitored for GBAS/E equipment.*

3.6.7.3.2 Data monitoring

3.6.7.3.2.1 *Broadcast quality monitor.* The ground subsystem monitoring shall comply with the time-to-alert requirements given in 3.6.7.1.2.1. The monitoring action shall be one of the following:

- a) to broadcast Type 1 or Type 101 messages with no measurement blocks; or
- b) to broadcast Type 1 or Type 101 messages with the $\sigma_{pr_gnd,i}$ field set to indicate the ranging source is invalid for every ranging source included in the previously transmitted frame; or

- c) to terminate the data broadcast.

Note.— Monitoring actions a) and b) are preferred to c) if the particular failure mode permits such a response, because actions a) and b) typically have a reduced signal-in-space time-to-alert.

3.6.7.4 FUNCTIONAL REQUIREMENTS FOR AUTHENTICATION PROTOCOLS

3.6.7.4.1 Functional requirements for ground subsystems that support authentication

3.6.7.4.1.1 The ground system shall broadcast the additional data block 4 with the Type 2 message with the slot group definition field coded to indicate which slots are assigned to the ground station.

3.6.7.4.1.2 The ground subsystem shall broadcast every Type 2 message in the slot that corresponds to the SSID coding for the ground subsystem. Slot A is represented by SSID = 0, B by 1, C by 2, and H by 7.

3.6.7.4.1.3 *Assigned slot occupancy.* The ground subsystem shall transmit messages such that 87 per cent or more of every assigned slot is occupied. If necessary, Type 3 messages will be used to fill unused space in any assigned time slot.

3.6.7.4.1.4 *Reference path identifier coding.* Every reference path identifier included in every final approach segment data block broadcast by the ground station via the Type 4 messages shall have the first letter selected to indicate the SSID of the ground station in accordance with the following coding.

Coding: A = SSID of 0
X = SSID of 1
Z = SSID of 2
J = SSID of 3
C = SSID of 4
V = SSID of 5
P = SSID of 6
T = SSID of 7

3.6.7.4.2 Functional requirements for ground subsystems that do not support authentication

3.6.7.4.2.1 *Reference path indicator coding.* Characters in this set: {A X Z J C V P T} shall not be used as the first character of the reference path identifier included in any FAS block broadcast by the ground station via the Type 4 messages.

3.6.8 AIRCRAFT ELEMENTS

3.6.8.1 *GNSS receiver.* The GBAS-capable GNSS receiver shall process signals of GBAS in accordance with the requirements specified in this section as well as with requirements in 3.1.3.1 and/or 3.2.3.1 and/or 3.5.8.1.

3.6.8.2 PERFORMANCE REQUIREMENTS

3.6.8.2.1 GBAS aircraft receiver accuracy

3.6.8.2.1.1 The RMS of the total aircraft receiver contribution to the error for GPS and GLONASS shall be:

$$\text{RMS}_{\text{pr_air}}(\theta_n) \leq a_0 + a_1 \times e^{-(\theta_n/\theta_0)}$$

where

- n = the nth ranging source;
- θ_n = the elevation angle for the nth ranging source; and
- a_0 , a_1 , and θ_0 = as defined in Table B-77 for GPS and Table B-78 for GLONASS.

3.6.8.2.1.2 The RMS of the total aircraft receiver contribution to the error for SBAS satellites shall be as defined in 3.5.8.2.1 for each of the defined aircraft accuracy designators.

Note.— The aircraft receiver contribution does not include the measurement error induced by airframe multipath.

Table B-77. Aircraft GPS receiver accuracy requirement

Aircraft accuracy designator	θ_n (degrees)	a_0 (metres)	a_1 (metres)	θ_0 (degrees)
A	≥5	0.15	0.43	6.9
B	≥5	0.11	0.13	4

Table B-78. Aircraft GLONASS receiver accuracy requirement

Aircraft accuracy designator	θ_n (degrees)	a_0 (metres)	a_1 (metres)	θ_0 (degrees)
A	≥5	0.39	0.9	5.7
B	≥5	0.105	0.25	5.5

3.6.8.2.2 *VHF data broadcast receiver performance*

3.6.8.2.2.1 *VHF data broadcast tuning range.* The VHF data broadcast receiver shall be capable of tuning frequencies in the range of 108.000 – 117.975 MHz in increments of 25 kHz.

3.6.8.2.2.2 *VHF data broadcast capture range.* The VHF data broadcast receiver shall be capable of acquiring and maintaining lock on signals within ±418 Hz of the nominal assigned frequency.

Note.— The frequency stability of the GBAS ground subsystem, and the worst-case doppler shift due to the motion of the aircraft, are reflected in the above requirement. The dynamic range of the automatic frequency control should also consider the frequency-stability error budget of the aircraft VHF data broadcast receiver.

3.6.8.2.2.3 *VHF data broadcast sensitivity, range and message failure rate.* The VHF data broadcast receiver shall achieve a message failure rate less than or equal to one failed message per 1 000 full-length (222 bytes) application data messages, while operating over a range from –87 dBm to –1 dBm, provided that the variation in the average received signal power between successive bursts in a given time slot does not exceed 40 dB. Failed messages include those lost by the VHF data broadcast receiver system or which do not pass the CRC after application of the FEC.

Note.— Aircraft VHF data broadcast receiving antenna can be horizontally or vertically polarized. Due to the difference in the signal strength of horizontally and vertically polarized components of the broadcast signal, the total aircraft implementation loss is limited to 15 dB for horizontally polarized receiving antennas and 11 dB for vertically polarized receiving antennas.

3.6.8.2.2.4 *VHF data broadcast time slot decoding.* The VHF data broadcast receiver shall meet the requirements of 3.6.8.2.2.3 for all Type 1, 2 and 4 messages from the selected GBAS ground subsystem. These requirements shall be met in the presence of other GBAS transmissions in any and all time slots respecting the levels as indicated in 3.6.8.2.2.5.1 b).

Note.— Other GBAS transmissions may include: a) messages other than Type 1, 2 and 4 with the same SSID, and b) messages with different SSIDs

3.6.8.2.2.4.1 *Decoding of Type 101 messages.* A VHF data broadcast receiver capable of receiving Type 101 messages, shall meet the requirements of 3.6.8.2.2.3 for all Type 101 messages from the selected GBAS ground subsystem. These requirements shall be met in the presence of other GBAS transmissions in any and all time slots respecting the levels as indicated in 3.6.8.2.2.5.1 b).

3.6.8.2.2.5 *Co-channel rejection*

3.6.8.2.2.5.1 *VHF data broadcast as the undesired signal source.* The VHF data broadcast receiver shall meet the requirements specified in 3.6.8.2.2.3 in the presence of an undesired co-channel VHF data broadcast signal that is either:

- a) assigned to the same time slot(s) and 26 dB below the desired VHF data broadcast signal power or lower; or
- b) assigned different time slot(s) and whose power is up to 15 dBm at the receiver input.

3.6.8.2.2.5.2 *VOR as the undesired signal.* The VHF data broadcast receiver shall meet the requirements specified in 3.6.8.2.2.3 in the presence of an undesired co-channel VOR signal that is 26 dB below the desired VHF data broadcast signal power.

3.6.8.2.2.6 *Adjacent channel rejection*

3.6.8.2.2.6.1 *First adjacent 25 kHz channels (± 25 kHz).* The VHF data broadcast receiver shall meet the requirements specified in 3.6.8.2.2.3 in the presence of a transmitted undesired signal offset by 25 kHz on either side of the desired channel that is either:

- a) 18 dB above the desired signal power when the undesired signal is another VHF data broadcast signal assigned to the same time slot(s); or
- b) equal in power when the undesired signal is VOR.

3.6.8.2.2.6.2 *Second adjacent 25 kHz channels (± 50 kHz).* The VHF data broadcast receiver shall meet the requirements specified in 3.6.8.2.2.3 in the presence of a transmitted undesired signal offset by 50 kHz on either side of the desired channel that is either:

- a) 43 dB above the desired signal power when the undesired signal is another VHF data broadcast source assigned to the same time slot(s); or
- b) 34 dB above the desired signal power when the undesired signal is VOR.

3.6.8.2.2.6.3 *Third and beyond adjacent 25 kHz channels (± 75 kHz or more).* The VHF data broadcast receiver shall meet the requirements specified in 3.6.8.2.2.3 in the presence of a transmitted undesired signal offset by 75 kHz or more on either side of the desired channel that is either:

- a) 46 dB above the desired signal power when the undesired signal is another VHF data broadcast signal assigned to the same time slot(s); or
- b) 46 dB above the desired signal power when the undesired signal is VOR.

3.6.8.2.2.7 *Rejection of off-channel signals from sources inside the 108.000 – 117.975 MHz band.* With no on-channel VHF data broadcast signal present, the VHF data broadcast receiver shall not output data from an undesired VHF data broadcast signal on any other assignable channel.

3.6.8.2.2.8 *Rejection of signals from sources outside the 108.000 – 117.975 MHz band*

3.6.8.2.2.8.1 *VHF data broadcast interference immunity.* The VHF data broadcast receiver shall meet the requirements specified in 3.6.8.2.2.3 in the presence of one or more signals having the frequency and total interference levels specified in Table B-79.

3.6.8.2.2.8.2 *Desensitization.* The VHF data broadcast receiver shall meet the requirements specified in 3.6.8.2.2.3 in the presence of VHF FM broadcast signals with signal levels shown in Tables B-80 and B-81.

Table B-79. Maximum levels of undesired signals

Frequency	Maximum level of undesired signals at the receiver input (dBm)
50 kHz up to 88 MHz	-13
88 MHz – 107.900 MHz	(see 3.6.8.2.2.8.2)
108.000 MHz – 117.975 MHz	excluded
118.000 MHz	-44
118.025 MHz	-41
118.050 MHz up to 1 660.5 MHz	-13

Notes.—

1. *The relationship is linear between single adjacent points designated by the above frequencies.*
2. *These interference immunity requirements may not be adequate to ensure compatibility between VHF data broadcast receivers and VHF communication systems, particularly for aircraft that use the vertically polarized component of the VHF data broadcast. Without coordination between COM and NAV frequencies assignments or respect of a guard band at the top end of the 112 – 117.975 MHz band, the maximum levels quoted at the lowest COM VHF channels (118.000, 118.00833, 118.01666, 118.025, 118.03333, 118.04166, 118.05) may be exceeded at the input of the VDB receivers. In that case, some means to attenuate*

the COM signals at the input of the VDB receivers (e.g. antenna separation) will have to be implemented. The final compatibility will have to be assured when equipment is installed on the aircraft.

Table B-80. Desensitization frequency and power requirements that apply for VDB frequencies from 108.025 to 111.975 MHz

Frequency	Maximum level of undesired signals at the receiver input (dBm)
88 MHz ≤ f ≤ 102 MHz	15
104 MHz	10
106 MHz	5
107.9 MHz	-10

Notes.—

1. The relationship is linear between single adjacent points designated by the above frequencies.
2. This desensitization requirement is not applied for FM carriers above 107.7 MHz and VDB channels at 108.025 or 108.050 MHz. See Attachment D, 7.2.1.2.2.

Table B-81. Desensitization frequency and power requirements that apply for VDB frequencies from 112.000 to 117.975 MHz

Frequency	Maximum level of undesired signals at the receiver input (dBm)
88 MHz ≤ f ≤ 104 MHz	15
106 MHz	10
107 MHz	5
107.9 MHz	0

Note.— The relationship is linear between single adjacent points designated by the above frequencies.

3.6.8.2.2.8.3 VHF data broadcast FM intermodulation immunity. The VHF data broadcast receiver shall meet the requirements specified in 3.6.8.2.2.3 in the presence of interference from two-signal, third-order intermodulation products of two VHF FM broadcast signals having levels in accordance with the following:

$$2N_1 + N_2 + 72 \leq 0$$

for VHF FM sound broadcasting signals in the range 107.7 – 108.0 MHz and

$$2N_1 - N_2 - 32 - 20 \log \frac{\Delta f}{0.4} \leq 0$$

for VHF FM sound broadcasting signals below 107.7 MHz

where the frequencies of the two VHF FM sound broadcasting signals produce, within the receiver, a two signal, third-order intermodulation product on the desired VDB frequency.

N_1 and N_2 are the levels (dBm) of the two VHF FM sound broadcasting signals at the VHF data broadcast receiver input.

Neither level shall exceed the desensitization criteria set forth in 3.6.8.2.2.8.2.

$f = 108.1 - f_1$, where f_1 is the frequency of N_1 , the VHF FM sound broadcasting signal closer to 108.1 MHz.

Note.— The FM intermodulation immunity requirements are not applied to a VHF data broadcast channel operating below 108.1 MHz, hence frequencies below 108.1 MHz are not intended for general assignments. Additional information is provided in Attachment D, 7.2.1.2.

3.6.8.3 AIRCRAFT FUNCTIONAL REQUIREMENTS

3.6.8.3.1 Conditions for use of data

3.6.8.3.1.1 The receiver shall use data from a GBAS message only if the CRC of that message has been verified.

3.6.8.3.1.2 The receiver shall use message data only if the message block identifier is set to the bit pattern “1010 1010”.

3.6.8.3.1.2.1 *GBAS message processing capability.* The GBAS receiver shall at a minimum process GBAS message types in accordance with Table B-82.

Table B-82. Airborne equipment message type processing

Airborne equipment designed performance	Minimum message types processed
APV-I	MT 1 or 101, MT 2 (including ADB 1 and 2 if provided)
APV-II	MT1,MT2 (including ADB 1 and 2 if provided), MT 4
Category I	MT1,MT2 (including ADB 1 if provided), MT 4

3.6.8.3.1.2.2 Airborne processing for forward compatibility

Note.— Provisions have been made to enable future expansion of the GBAS Standards to support new capabilities. New message types may be defined, new additional data blocks for message Type 2 may be defined and new data blocks defining reference paths for inclusion within message Type 4 may be defined. To facilitate these future expansions, all equipment should be designed to properly ignore all data types that are not recognized.

3.6.8.3.1.2.2.1 *Processing of unknown message types.* The existence of messages unknown to the airborne receiver shall not prevent correct processing of the required messages.

3.6.8.3.1.2.2.2 *Processing of unknown Type 2 extended data blocks.* The existence of message Type 2 additional data blocks unknown to the airborne receiver shall not prevent correct processing of the required messages.

3.6.8.3.1.2.2.3 *Processing of unknown Type 4 data blocks.* The existence of message Type 4 data blocks unknown to the airborne receiver shall not prevent correct processing of the required messages.

Note.— While the current SARPs include only one definition of a data block for inclusion within a Type 4 message, future GBAS Standards may include other reference path definitions.

3.6.8.3.1.3 The receiver shall use only ranging source measurement blocks with matching modified Z-counts.

3.6.8.3.1.4 If D_{max} is broadcast by the ground subsystem, the receiver shall only apply pseudo-range corrections when the distance to the GBAS reference point is less than D_{max} .

3.6.8.3.1.5 The receiver shall only apply pseudo-range corrections from the most recently received set of corrections for a given measurement type. If the number of measurement fields in the most recently received Type 1 or Type 101 message indicates that there are no measurement blocks, then the receiver shall not apply GBAS corrections for that measurement type.

3.6.8.3.1.6 The receiver shall exclude from the differential navigation solution any ranging sources for which σ_{pr_gnd} is set to the bit pattern “1111 1111”.

3.6.8.3.1.7 The receiver shall only use a ranging source in the differential navigation solution if the time of applicability indicated by the modified Z-count in the Type 1 or Type 101 message containing the ephemeris decorrelation parameter for that ranging source is less than 120 seconds old.

3.6.8.3.1.8 *Conditions for use of data to support Category I precision approach and APV*

3.6.8.3.1.8.1 During the final stages of a Category I or APV approach, the receiver shall use only measurement blocks from Type 1 or Type 101 messages that were received within the last 3.5 seconds.

3.6.8.3.1.8.2 The receiver shall use message data from a GBAS ground subsystem for Category I precision approach or APV guidance only if the GCID indicates 1, 2, 3 or 4 prior to initiating the final stages of an approach.

3.6.8.3.1.8.3 The receiver shall ignore any changes in GCID during the final stages of an approach.

3.6.8.3.1.8.4 The receiver shall not provide approach vertical guidance based on a particular FAS data block transmitted in a Type 4 message if the FASVAL received prior to initiating the final stages of the approach is set to “1111 1111”.

3.6.8.3.1.8.5 The receiver shall not provide approach guidance based on a particular FAS data block transmitted in a Type 4 message if the FASLAL received prior to initiating the final stages of the approach is set to “1111 1111”.

3.6.8.3.1.8.6 Changes in the values of FASLAL and FASVAL data transmitted in a Type 4 message during the final stages of an approach shall be ignored by the receiver.

3.6.8.3.1.8.7 The receiver shall use FAS data only if the FAS CRC for that data has been verified.

3.6.8.3.1.8.8 The receiver shall only use messages for which the GBAS ID (in the message block header) matches the GBAS ID in the header of the Type 4 message which contains the selected FAS data or the Type 2 message which contains the selected RSDS.

3.6.8.3.1.8.9 *Use of FAS data*

3.6.8.3.1.8.9.1 The receiver shall use the Type 4 messages to determine the FAS for precision approach.

3.6.8.3.1.8.9.2 The receiver shall use the Type 4 messages to determine the FAS for APV associated with a channel number between 20 001 and 39 999.

3.6.8.3.1.8.9.3 The receiver shall use the FAS held within the on-board database for APV associated with a channel number between 40 000 and 99 999.

3.6.8.3.1.8.10 When the GBAS ground subsystem does not broadcast the Type 4 message and the selected FAS data are available to the receiver from an airborne database, the receiver shall only use messages from the intended GBAS ground subsystem.

3.6.8.3.1.9 *Conditions for use of data to provide the GBAS positioning service*

3.6.8.3.1.9.1 The receiver shall only use measurement blocks from Type 1 messages that were received within the last 7.5 seconds.

3.6.8.3.1.9.2 The receiver shall only use measurement blocks from Type 101 messages that were received within the last 5 seconds.

3.6.8.3.1.9.3 The receiver shall only use message data if a Type 2 message containing additional data block 1 has been received and the RSDS parameter in this block indicates that the GBAS positioning service is provided.

3.6.8.3.1.9.4 The receiver shall only use messages for which the GBAS ID (in the message block header) matches the GBAS ID in the header of the Type 2 message which contains the selected RSDS.

3.6.8.3.2 *Integrity*

3.6.8.3.2.1 *Bounding of aircraft errors.* For each satellite used in the navigation solution, the receiver shall compute a σ_{receiver} such that a normal distribution with zero mean and a standard deviation equal to σ_{receiver} bounds the receiver contribution to the corrected pseudo-range error as follows:

$$\int_y^{\infty} f(x) dx \leq Q \frac{y}{\sigma} \quad \text{for all } \frac{y}{\sigma} \geq 0 \text{ and}$$

$$\int_{-\infty}^{-y} f(x) dx \leq Q \frac{y}{\sigma} \quad \text{for all } \frac{y}{\sigma} \geq 0$$

where

$f(x)$ = probability density function of the residual aircraft pseudo-range error and

$$Q = \frac{1}{\sqrt{2\pi}} \int_x^{\infty} e^{-\frac{t^2}{2}} dt$$

3.6.8.3.2.2 *Use of GBAS integrity parameters.* The aircraft element shall compute and apply the vertical, lateral and horizontal protection levels described in 3.6.5.5 using the GBAS broadcast $\sigma_{\text{pr_gnd}}$, σ_N , h_0 , $\sigma_{\text{vert_iono_gradient}}$, and B parameters as well as the $\sigma_{\text{pr_air}}$ parameter. If a $B_{i,j}$ parameter is set to the bit pattern “1000 0000” indicating that the measurement is not available, the aircraft element shall assume that $B_{i,j}$ has a value of zero. For Category I precision approach and APV, the aircraft element shall verify that the computed vertical and lateral protection levels are smaller than the corresponding vertical and lateral alert limits defined in 3.6.5.6.

3.6.8.3.3 *Use of satellite ephemeris data*

3.6.8.3.3.1 *IOD check.* The receiver shall only use satellites for which the IOD broadcast by GBAS in the Type 1 or Type 101 message matches the core satellite constellation IOD for the clock and ephemeris data used by the receiver.

3.6.8.3.3.2 *CRC check.* The receiver shall compute the ephemeris CRC for each core satellite constellation's ranging source used in the position solution. The computed CRC shall be validated against the ephemeris CRC broadcast in the Type 1 or Type 101 messages within one second of receiving a new broadcast CRC. The receiver shall immediately cease using any satellite for which the computed and broadcast CRC values fail to match.

Note.— During initial acquisition of the VHF data broadcast, the receiver may incorporate a satellite into the position solution before receiving the broadcast ephemeris CRC for that satellite.

3.6.8.3.3.3 *Ephemeris error position bounds*

3.6.8.3.3.3.1 *Ephemeris error position bounds for Category I precision approach and APV.* If the ground subsystem provides additional data block 1 in the Type 2 messages, the aircraft element shall compute the ephemeris error position bounds defined in 3.6.5.8.1 for each core satellite constellation's ranging source used in the position solution within 1s of receiving the necessary broadcast parameters. The aircraft element shall exclude from the position solution satellites for which the computed vertical or lateral ephemeris error position bounds (VEB_j or LEB_j) are larger than the corresponding vertical and lateral alert limits defined in 3.6.5.6.

Note.— During initial acquisition of the VHF data broadcast, the receiver may incorporate a satellite into the position solution before receiving the necessary broadcast parameters for that satellite to compute the ephemeris error position bounds.

3.6.8.3.3.3.2 *Ephemeris error position bound for the GBAS positioning service.* The aircraft element shall compute and apply the horizontal ephemeris error position bound (HEB_j) defined in 3.6.5.8.2 for each core satellite constellation's ranging source used in the position solution.

3.6.8.3.4 *Message loss*

3.6.8.3.4.1 For Category I precision approach, the receiver shall provide an appropriate alert if no Type 1 or Type 101 message was received during the last 3.5 seconds.

3.6.8.3.4.2 For APV, the receiver shall provide an appropriate alert if no Type 1 and no Type 101 message was received during the last 3.5 seconds.

3.6.8.3.4.3 For the GBAS positioning service using Type 1 messages, the receiver shall provide an appropriate alert if no Type 1 message was received during the last 7.5 seconds.

3.6.8.3.4.4 For the GBAS positioning service using Type 101 messages, the receiver shall provide an appropriate alert if no Type 101 message was received during the last 5 seconds.

3.6.8.3.5 *Airborne pseudo-range measurements*

3.6.8.3.5.1 *Carrier smoothing for airborne equipment.* Airborne equipment shall utilize the standard 100-second carrier smoothing of code phase measurements defined in 3.6.5.1. During the first 100 seconds after filter start-up, the value of α shall be either:

- a) a constant equal to the sample interval divided by 100 seconds; or
- b) a variable quantity defined by the sample interval divided by the time in seconds since filter start-up.

3.7 Resistance to interference

3.7.1 PERFORMANCE OBJECTIVES

Note 1.— For unaugmented GPS and GLONASS receivers the resistance to interference is measured with respect to the following performance parameters:

	GPS	GLONASS
Tracking error (1 sigma)	0.4 m	0.8 m

Note 2.— This tracking error neither includes contributions due to signal propagation such as multipath, tropospheric and ionospheric effects nor ephemeris and GPS and GLONASS satellite clock errors.

Note 3.— For SBAS receivers, the resistance to interference is measured with respect to parameters specified in 3.5.8.2.1 and 3.5.8.4.1.

Note 4.— For GBAS receivers, the resistance to interference is measured with respect to parameters specified in 3.6.7.1.1 and 3.6.8.2.1.

Note 5.— The signal levels specified in this section are defined at the antenna port. Assumed maximum aircraft antenna gain in the lower hemisphere is -10 dBic.

Note 6.— The performance requirements are to be met in the interference environments defined below for various phases of flight.

3.7.2 CONTINUOUS WAVE (CW) INTERFERENCE

3.7.2.1 GPS AND SBAS RECEIVERS

3.7.2.1.1 GPS and SBAS receivers used for the precision approach phase of flight or used on aircraft with on-board satellite communications shall meet the performance objectives with CW interfering signals present with a power level at the antenna port equal to the interference thresholds specified in Table B-83 and shown in Figure B-15 and with a desired signal level of -164.5 dBW at the antenna port.

3.7.2.1.2 GPS and SBAS receivers used for non-precision approach shall meet the performance objectives with interference thresholds 3 dB less than specified in Table B-83. For terminal area and en-route steady-state navigation operations and for initial acquisition of the GPS and SBAS signals prior to steady-state navigation, the interference thresholds shall be 6 dB less than those specified in Table B-83.

Table B-83. CW interference thresholds for GPS and SBAS receivers

Frequency range f_i of the interference signal	Interference thresholds for receivers used for precision approach phase of flight
$f_i \leq 1\ 315$ MHz	-4.5 dBW

1 315 MHz < f_i ≤ 1 525 MHz	Linearly decreasing from -4.5 dBW to -42 dBW
1 525 MHz < f_i ≤ 1 565.42 MHz	Linearly decreasing from -42 dBW to -150.5 dBW
1 565.42 MHz < f_i ≤ 1 585.42 MHz	-150.5 dBW
1 585.42 MHz < f_i ≤ 1 610 MHz	Linearly increasing from -150.5 dBW to -60 dBW
1 610 MHz < f_i ≤ 1 618 MHz	Linearly increasing from -60 dBW to -42 dBW*
1 618 MHz < f_i ≤ 2 000 MHz	Linearly increasing from -42 dBW to -8.5 dBW*
1 610 MHz < f_i ≤ 1 626.5 MHz	Linearly increasing from -60 dBW to -22 dBW**
1 626.5 MHz < f_i ≤ 2 000 MHz	Linearly increasing from -22 dBW to -8.5 dBW**
f_i > 2 000 MHz	-8.5 dBW

* Applies to aircraft installations where there are no on-board satellite communications.
 ** Applies to aircraft installations where there is on-board satellite communications.

3.7.2.2 *GLONASS RECEIVERS*

3.7.2.2.1 GLONASS receivers used for the precision approach phase of flight or used on aircraft with on-board satellite communications shall meet the performance objectives with CW interfering signals present with a power level at the antenna port equal to the interference thresholds specified in Table B-84 and shown in Figure B-16 and with a desired signal level of -165.5 dBW at the antenna port.

Table B-84. Interference threshold for GLONASS receivers

Frequency range f_i of the interference signal	Interference thresholds for receivers used for precision approach phase of flight
f_i ≤ 1 315 MHz	-4.5 dBW
1 315 MHz < f_i ≤ 1 562.15625 MHz	Linearly decreasing from -4.5 dBW to -42 dBW
1 562.15625 MHz < f_i ≤ 1 583.65625 MHz	Linearly decreasing from -42 dBW to -80 dBW
1 583.65625 MHz < f_i ≤ 1 592.9525 MHz	Linearly decreasing from -80 dBW to -149 dBW
1 592.9525 MHz < f_i ≤ 1 609.36 MHz	-149 dBW
1 609.36 MHz < f_i ≤ 1 613.65625 MHz	Linearly increasing from -149 dBW to -80 dBW
1 613.65625 MHz < f_i ≤ 1 635.15625 MHz	Linearly increasing from -80 dBW to -42 dBW*
1 613.65625 MHz < f_i ≤ 1 626.15625 MHz	Linearly increasing from -80 dBW to -22 dBW**
1 635.15625 MHz < f_i ≤ 2 000 MHz	Linearly increasing from -42 dBW to -8.5 dBW*
1 626.15625 MHz < f_i ≤ 2 000 MHz	Linearly increasing from -22 dBW to -8.5 dBW**
f_i > 2 000 MHz	-8.5 dBW

* Applies to aircraft installations where there are no on-board satellite communications.
 ** Applies to aircraft installations where there is on-board satellite communications.

3.7.2.2.2 GLONASS receivers used for non-precision approach shall meet the performance objectives with interference thresholds 3 dB less than specified in Table B-84. For terminal area and en-route steady-state navigation operations and for initial acquisition of the GLONASS signals prior to steady-state navigation, the interference thresholds shall be 6 dB less than those specified in Table B-84.

3.7.3 BAND-LIMITED NOISE-LIKE INTERFERENCE

3.7.3.1 *GPS AND SBAS RECEIVERS*

3.7.3.1.1 After steady-state navigation has been established, GPS and SBAS receivers used for the precision approach phase of flight or used on aircraft with on-board satellite communications shall meet the performance objectives with noise-like interfering signals present in the frequency range of $1\ 575.42\ \text{MHz} \pm Bw_i/2$ and with power levels at the antenna port equal to the interference thresholds specified in Table B-85 and Figure B-17 and with the desired signal level of $-164.5\ \text{dBW}$ at the antenna port.

Note.— Bw_i is the equivalent noise bandwidth of the interference signal.

3.7.3.1.2 GPS and SBAS receivers used for non-precision approach shall meet their performance objectives with interference thresholds for band-limited noise-like signals 3 dB less than specified in Table B-85. For terminal area and en-route steady-state navigation operations and for initial acquisition of the GPS and SBAS signals prior to steady-state navigation, the interference thresholds for band-limited noise-like signals shall be 6 dB less than those specified in Table B-85.

3.7.3.2 GLONASS RECEIVERS

3.7.3.2.1 After steady-state navigation has been established, GLONASS receivers used for the precision approach phase of flight or used on aircraft with on-board satellite communications shall meet the performance objectives while receiving noise-like interfering signals in the frequency band $f_k \pm Bw_i/2$, with power levels at the antenna port equal to the interference thresholds defined in Table B-86 and with a desired signal level of $-165.5\ \text{dBW}$ at the antenna port.

Note.— f_k is the centre frequency of a GLONASS channel with $f_k = 1\ 602\ \text{MHz} + k \times 0.6525\ \text{MHz}$ and $k = -7$ to $+13$ as defined in Table B-16 and Bw_i is the equivalent noise bandwidth of the interference signal.

3.7.3.2.2 GLONASS receivers used for non-precision approach shall meet their performance objectives with interference thresholds for band-limited noise-like signals 3 dB less than specified in Table B-85. For terminal area and en-route steady-state navigation operations, and for initial acquisition of the GLONASS signals prior to steady-state navigation, the interference thresholds for band-limited noise-like signals shall be 6 dB less than those specified in Table B-86.

Note.— For the approach phase of flight it is assumed that the receiver operates in tracking mode and acquires no new satellites.

3.7.3.3 *Pulsed interference.* After steady-state navigation has been established, the receiver shall meet the performance objectives while receiving pulsed interference signals with characteristics according to Table B-87 where the interference threshold is defined at the antenna port.

3.7.3.4 SBAS and GBAS receivers shall not output misleading information in the presence of interference including interference levels above those specified in 3.7.

Note.— Guidance material on this requirement is given in Attachment D, 10.6.

3.8 GNSS aircraft satellite receiver antenna

3.8.1 *Antenna coverage.* The GNSS antenna shall meet the performance requirements for the reception of GNSS satellite signals from 0 to 360 degrees in azimuth and from 0 to 90 degrees in elevation relative to the horizontal plane of an aircraft in level flight.

3.8.2 *Antenna gain.* The minimum antenna gain shall not be less than that shown in Table B-88 for the specified elevation angle above the horizon. The maximum antenna gain shall not exceed $+4\ \text{dBic}$ for elevation angles above 5 degrees.

3.8.3 *Polarization.* The GNSS antenna polarization shall be right-hand circular (clockwise with respect to the direction of propagation).

3.9 Cyclic redundancy check

Each CRC shall be calculated as the remainder, $R(x)$, of the Modulo-2 division of two binary polynomials as follows:

$$\frac{x^k M(x)}{G(x)} \text{ mod } 2 = Q(x) \frac{R(x)}{G(x)}$$

where

- k = the number of bits in the particular CRC;
- $M(x)$ = the information field, which consists of the data items to be protected by the particular CRC represented as a polynomial;
- $G(x)$ = the generator polynomial specified for the particular CRC;
- $Q(x)$ = the quotient of the division; and
- $R(x)$ = the remainder of the division, contains the CRC:

$$R(x) = r_1 x^{k-1} + r_2 x^{k-2} + \dots + r_k x^0$$

Table B-85. Interference threshold for band-limited noise-like interference to GPS and SBAS receivers used for precision approach

Interference bandwidth	Interference threshold
$0 \text{ Hz} < B_{w_i} \leq 700 \text{ Hz}$	-150.5 dBW
$700 \text{ Hz} < B_{w_i} \leq 10 \text{ kHz}$	$-150.5 + 6 \log_{10}(B_{w_i}/700) \text{ dBW}$
$10 \text{ kHz} < B_{w_i} \leq 100 \text{ kHz}$	$-143.5 + 3 \log_{10}(B_{w_i}/10000) \text{ dBW}$
$100 \text{ kHz} < B_{w_i} \leq 1 \text{ MHz}$	-140.5 dBW
$1 \text{ MHz} < B_{w_i} \leq 20 \text{ MHz}$	Linearly increasing from -140.5 to -127.5 dBW*
$20 \text{ MHz} < B_{w_i} \leq 30 \text{ MHz}$	Linearly increasing from -127.5 to -121.1 dBW*
$30 \text{ MHz} < B_{w_i} \leq 40 \text{ MHz}$	Linearly increasing from -121.1 to -119.5 dBW*
$40 \text{ MHz} < B_{w_i}$	-119.5 dBW*

* The interference threshold is not to exceed -140.5 dBW/MHz in the frequency range 1 575.42 ±10 MHz.

Table B-86. Interference threshold for band-limited noise-like interference to GLONASS receivers used for precision approach

Interference bandwidth	Interference threshold
$0 \text{ Hz} < B_{w_i} \leq 1 \text{ kHz}$	-149 dBW
$1 \text{ kHz} < B_{w_i} \leq 10 \text{ kHz}$	Linearly increasing from -149 to -143 dBW
$10 \text{ kHz} < B_{w_i} \leq 0.5 \text{ MHz}$	-143 dBW
$0.5 \text{ MHz} < B_{w_i} \leq 10 \text{ MHz}$	Linearly increasing from -143 to -130 dBW
$10 \text{ MHz} < B_{w_i}$	-130 dBW

Table B-87. Interference thresholds for pulsed interference

	GPS and SBAS	GLONASS
Frequency range	1 575.42 MHz \pm 10 MHz	1 592.9525 MHz to 1 609.36 MHz
Interference threshold (Pulse peak power)	-20 dBW	-20 dBW
Pulse width	\leq 125 μ s	\leq 250 μ s
Pulse duty cycle	\leq 1%	\leq 1%

Table B-88. Minimum antenna gain — GPS, GLONASS and SBAS

Elevation angle degrees	Minimum gain dBic
0	-7
5	-5.5
10	-4
15 to 90	-2.5

Note.— The -5.5 dBic gain at 5 degrees elevation angle is appropriate for an L1 antenna. A higher gain may be required in the future for GNSS signals in the L5/E5 band.

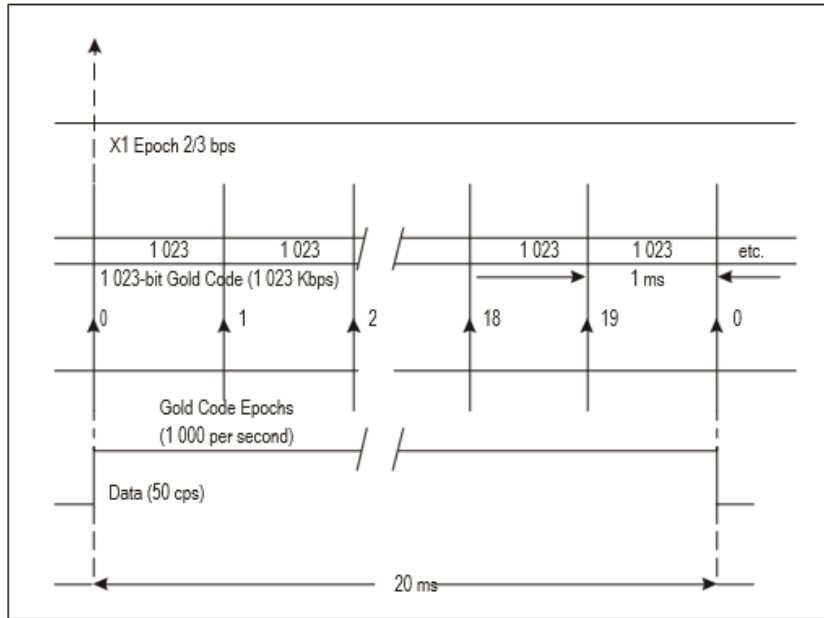

Figure B-1. C/A code timing relationships

SUBFRAME 1	TLM	HOW	GPS week number, SV accuracy and health
SUBFRAME 2	TLM	HOW	Ephemeris parameters
SUBFRAME 3	TLM	HOW	Ephemeris parameters
SUBFRAME 4 (25 pages)	TLM	HOW	Almanac and health for satellites 25–32, special messages, satellite configuration, flags, ionospheric and UTC
SUBFRAME 5 (25 pages)	TLM	HOW	Almanac and health for satellites 1–24 and almanac reference time and GPS week number

Figure B-2. Frame structure

Preamble								Reserved																Parity							
1	0	0	0	1	0	1	1	MSB																	LSB						
1	2	3	4	5	6	7	8	9	10	11	12	13	14	15	16	17	18	19	20	21	22	23	24	25	26	27	28	29	30		

Figure B-3. TLM word format

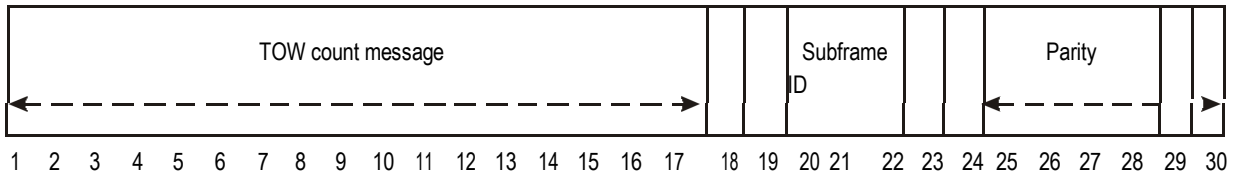

Figure B-4. HOW format

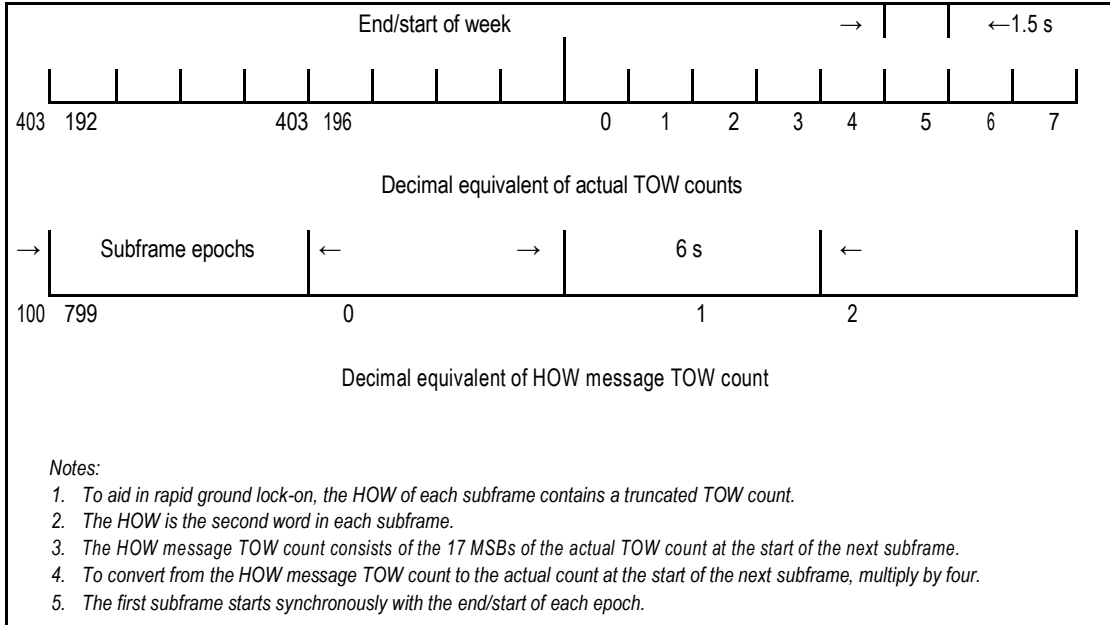
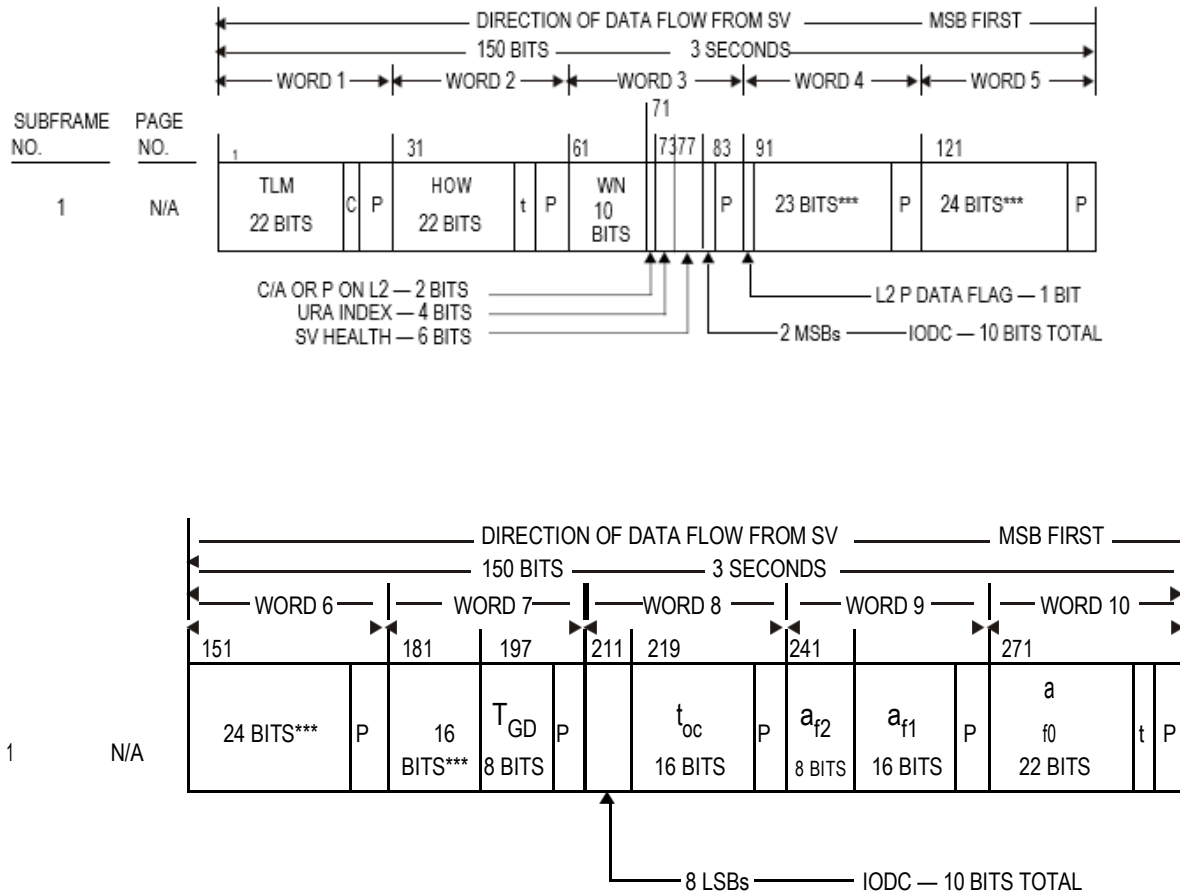

Figure B-5. Time line relationship of HOW



*** RESERVED

P = 6 PARITY BITS

t = 2 NON-INFORMATION BEARING BITS USED FOR PARITY COMPUTATION C

= TLM BITS 23 AND 24 WHICH ARE RESERVED

Figure B-6. Data format (1 of 11)

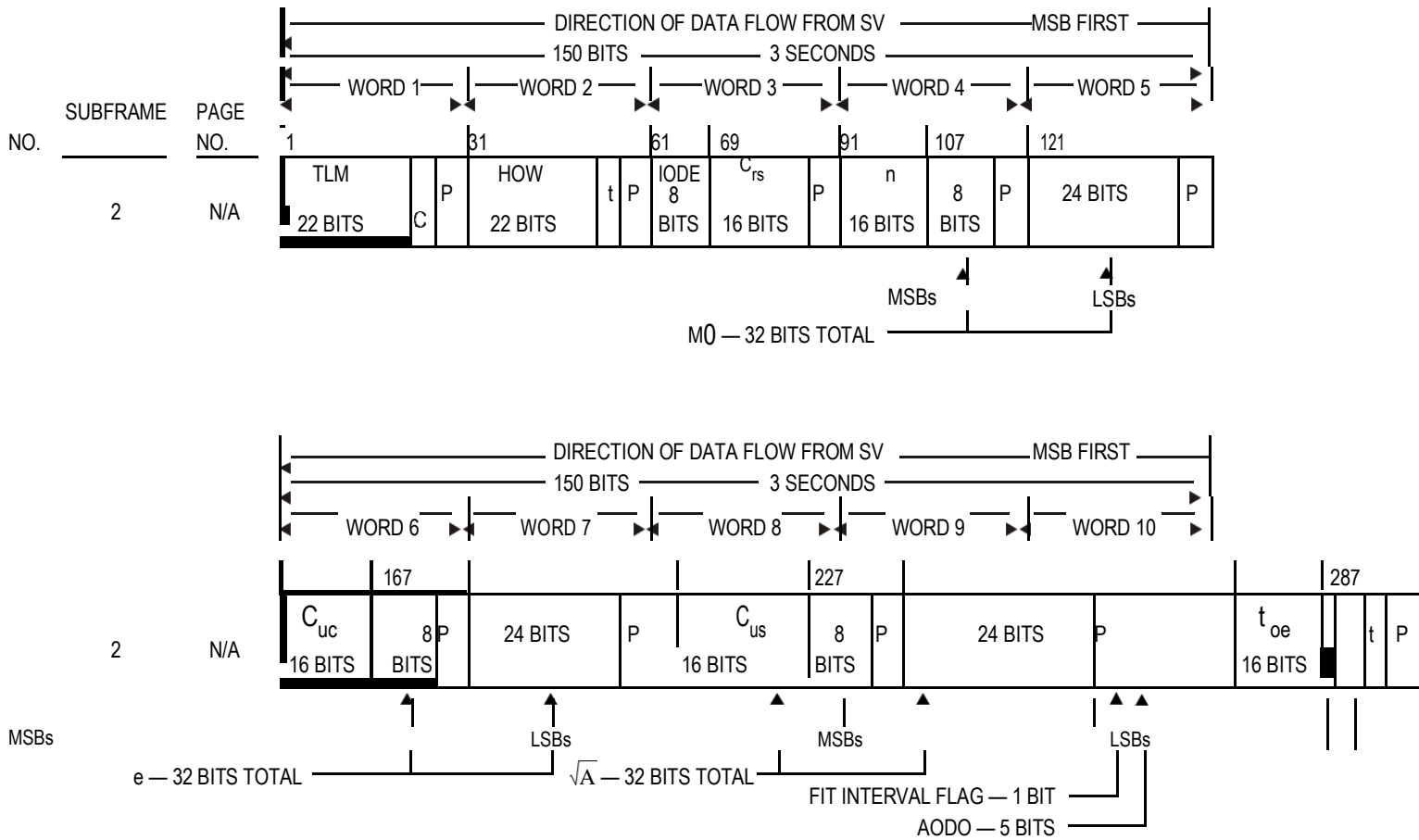

P = 6 PARITY BITS

t = 2 NON-INFORMATION BEARING BITS USED FOR PARITY COMPUTATION C

= TLM BITS 23 AND 24 WHICH ARE RESERVED

Figure B-6. Data format (2 of 11)

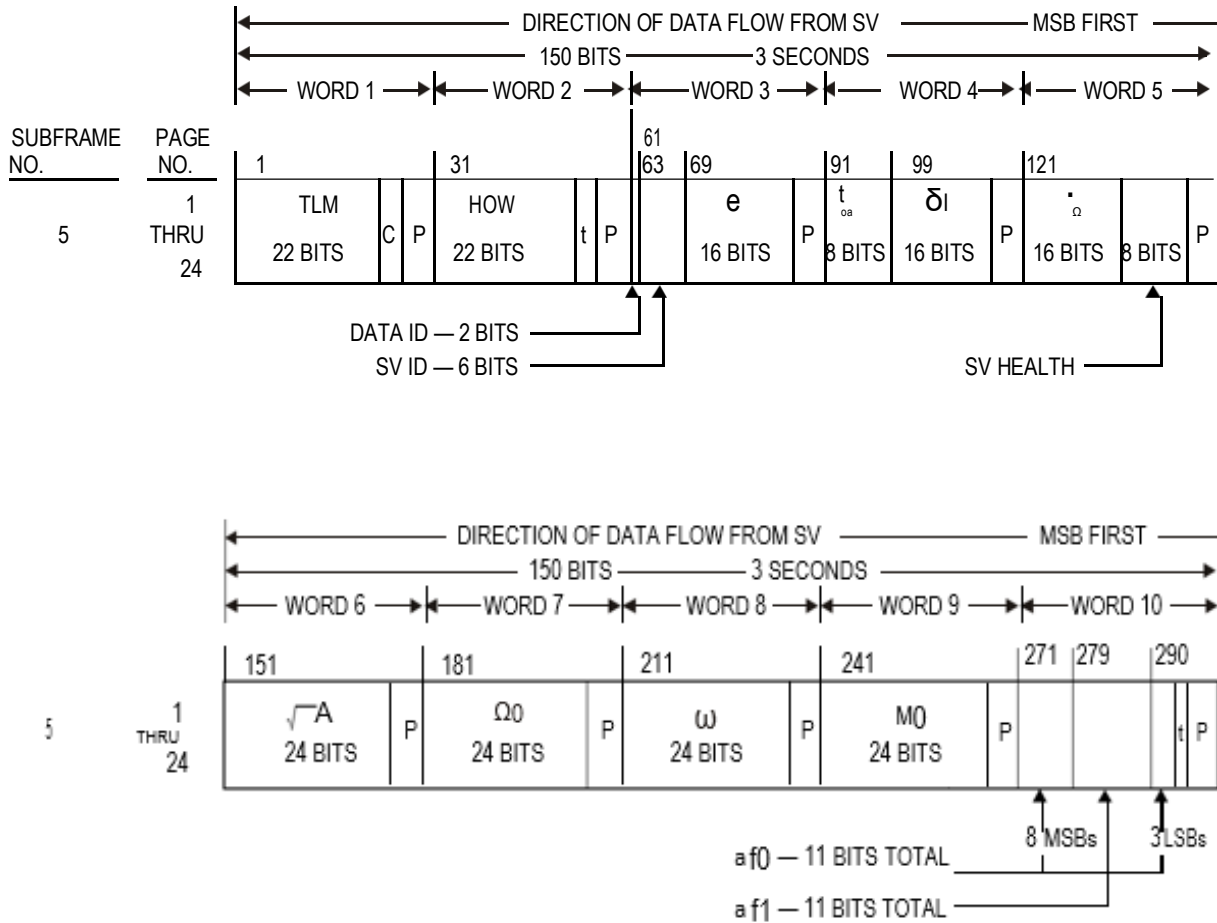

P = 6 PARITY BITS

t = 2 NON-INFORMATION BEARING BITS USED FOR PARITY COMPUTATION C

= TLM BITS 23 AND 24 WHICH ARE RESERVED

Note.— Pages 2, 3, 4, 5, 7, 8, 9 and 10 of subframe 4 have the same format as pages 1 through 24 of subframe 5.

Figure B-6. Data format (4 of 11)

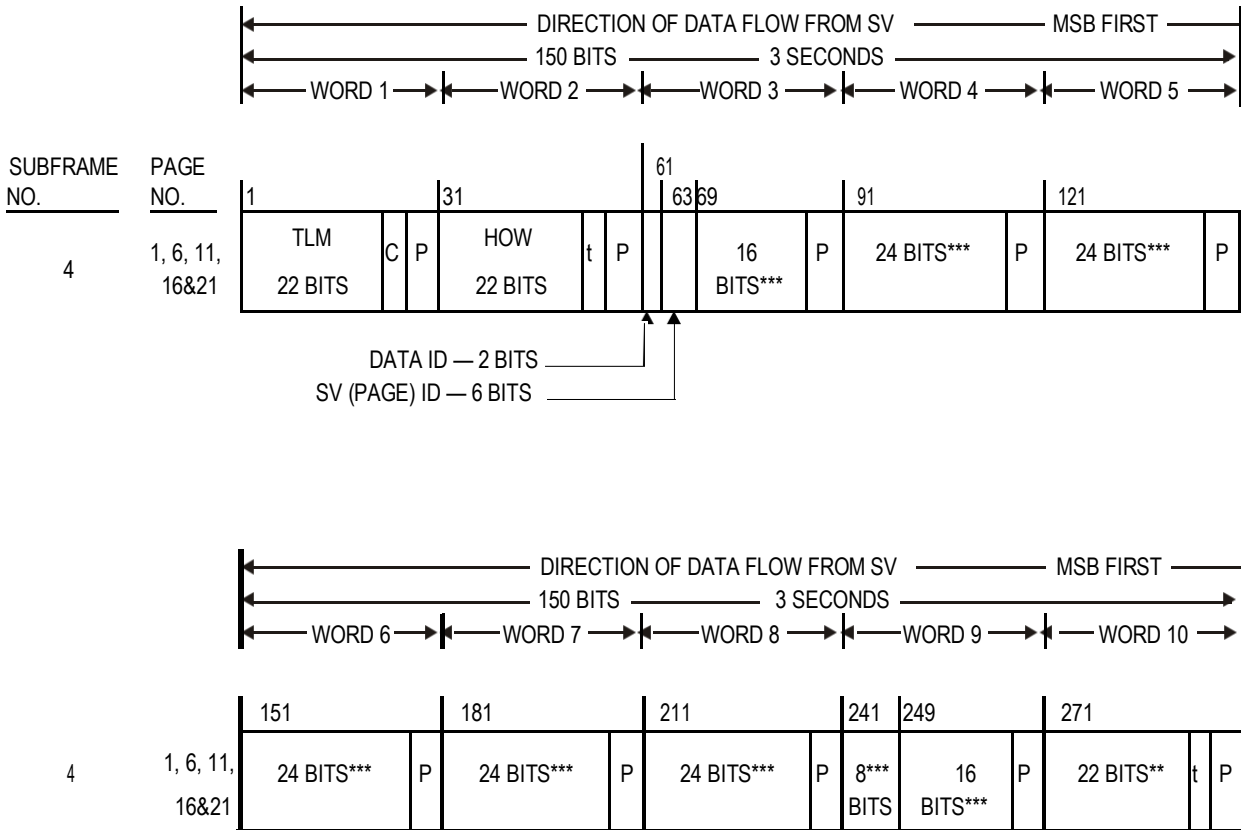

** RESERVED FOR SYSTEM USE
 *** RESERVED
 P = 6 PARITY BITS
 t = 2 NON-INFORMATION BEARING BITS USED FOR PARITY COMPUTATION C =
 TLM BITS 23 AND 24 WHICH ARE RESERVED

Figure B-6. Data format (6 of 11)

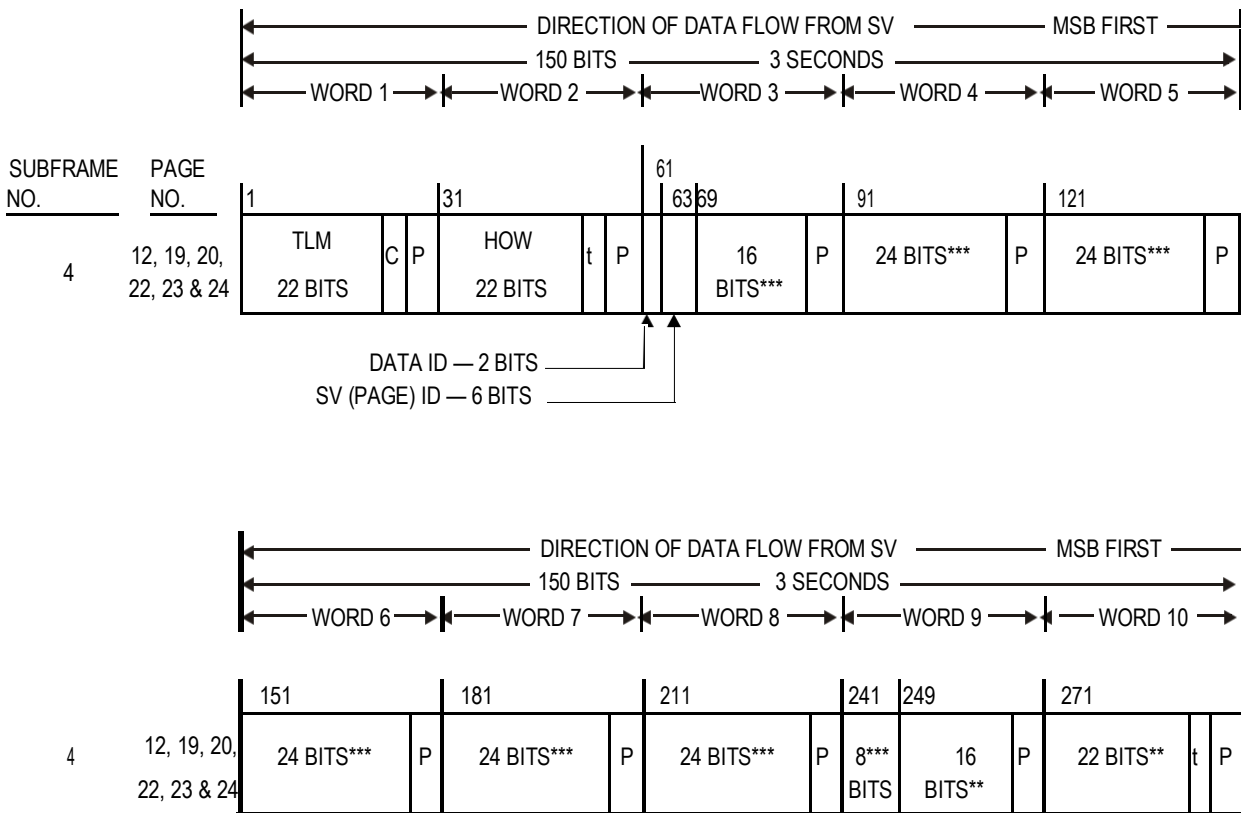

** RESERVED FOR SYSTEM USE

*** RESERVED

P = 6 PARITY BITS

t = 2 NON-INFORMATION BEARING BITS USED FOR PARITY COMPUTATION C =

TLM BITS 23 AND 24 WHICH ARE RESERVED

Figure B-6. Data format (7 of 11)

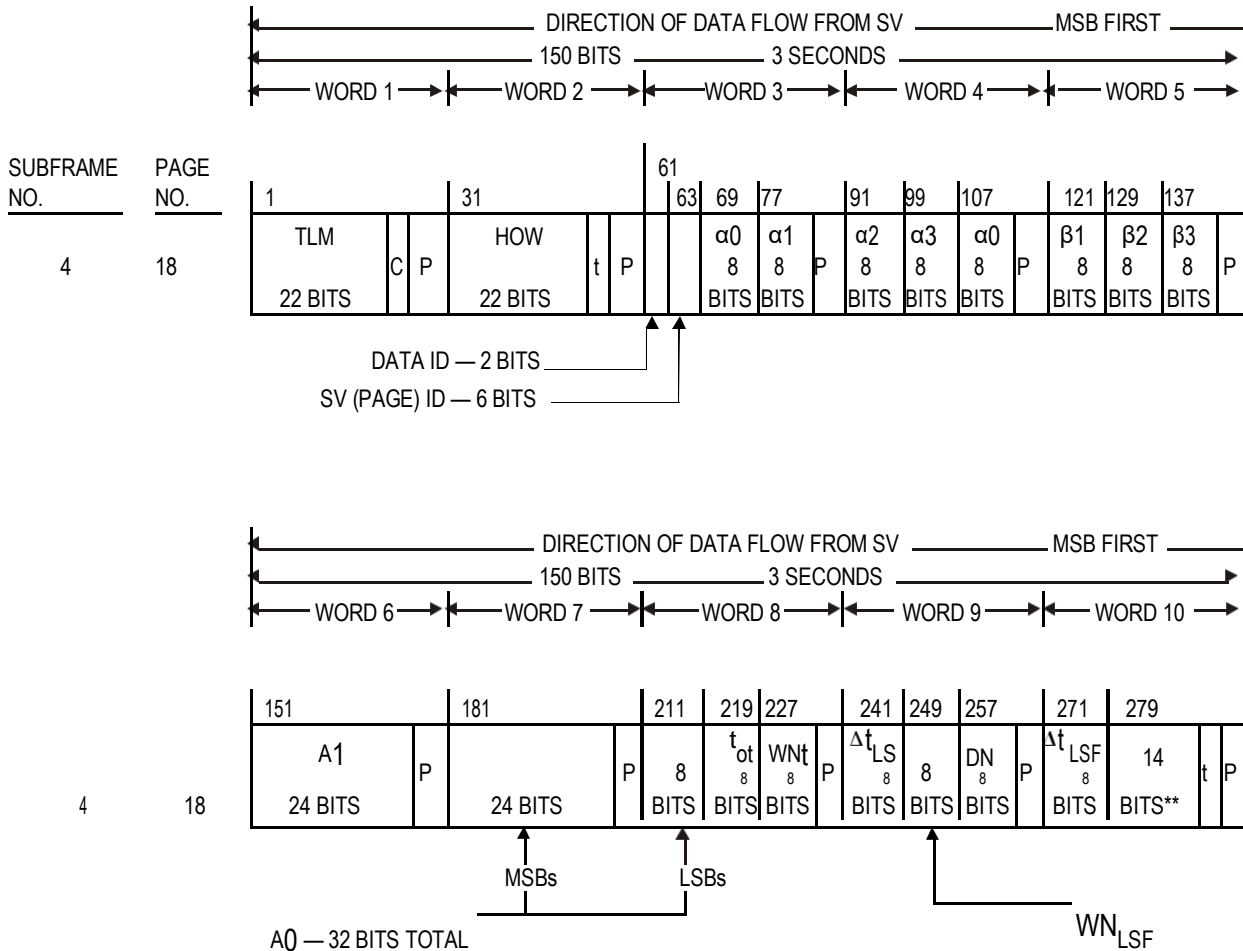

** RESERVED FOR SYSTEM USE P
= 6 PARITY BITS
t = 2 NON-INFORMATION BEARING BITS USED FOR PARITY COMPUTATION C =
TLM BITS 23 AND 24 WHICH ARE RESERVED

Figure B-6. Data format (8 of 11)

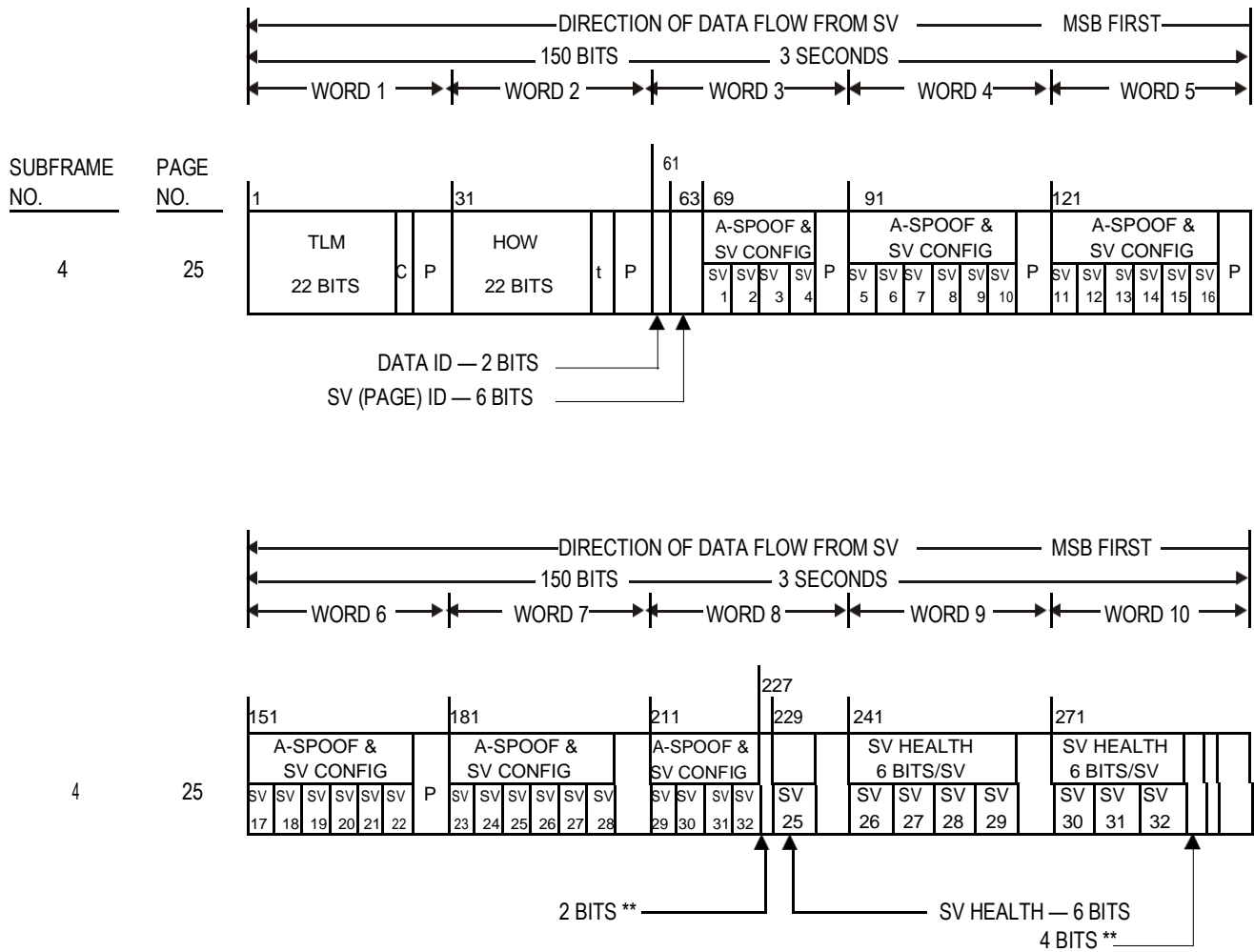

** RESERVED FOR SYSTEM USE P
= 6 PARITY BITS
t = 2 NON-INFORMATION BEARING BITS USED FOR PARITY COMPUTATION C =
TLM BITS 23 AND 24 WHICH ARE RESERVED

Figure B-6. Data format (9 of 11)

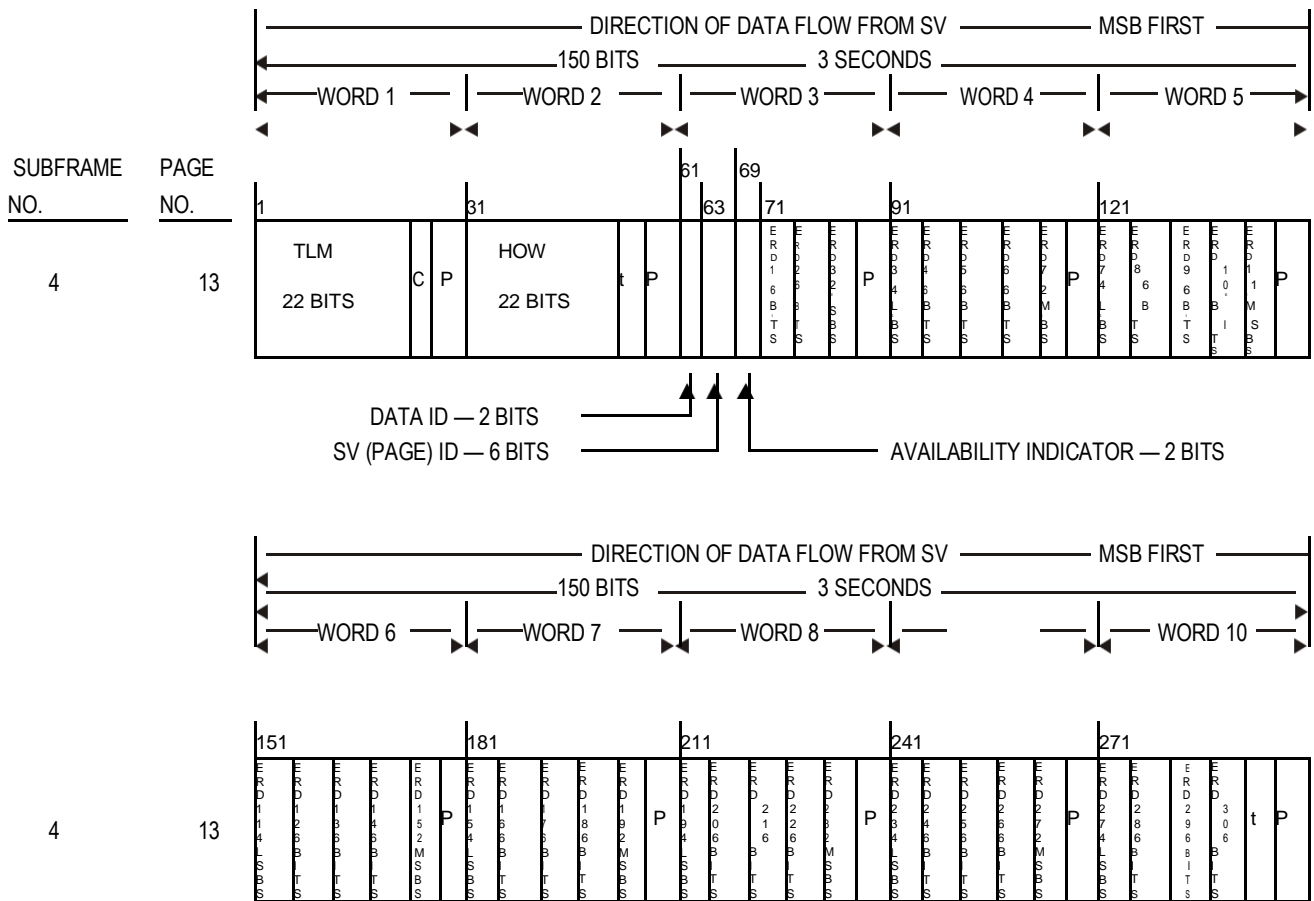

P = 6 PARITY BITS
t = 2 NON-INFORMATION BEARING BITS USED FOR PARITY COMPUTATION C
= TLM BITS 23 AND 24 WHICH ARE RESERVED

Figure B-6. Data format (10 of 11)

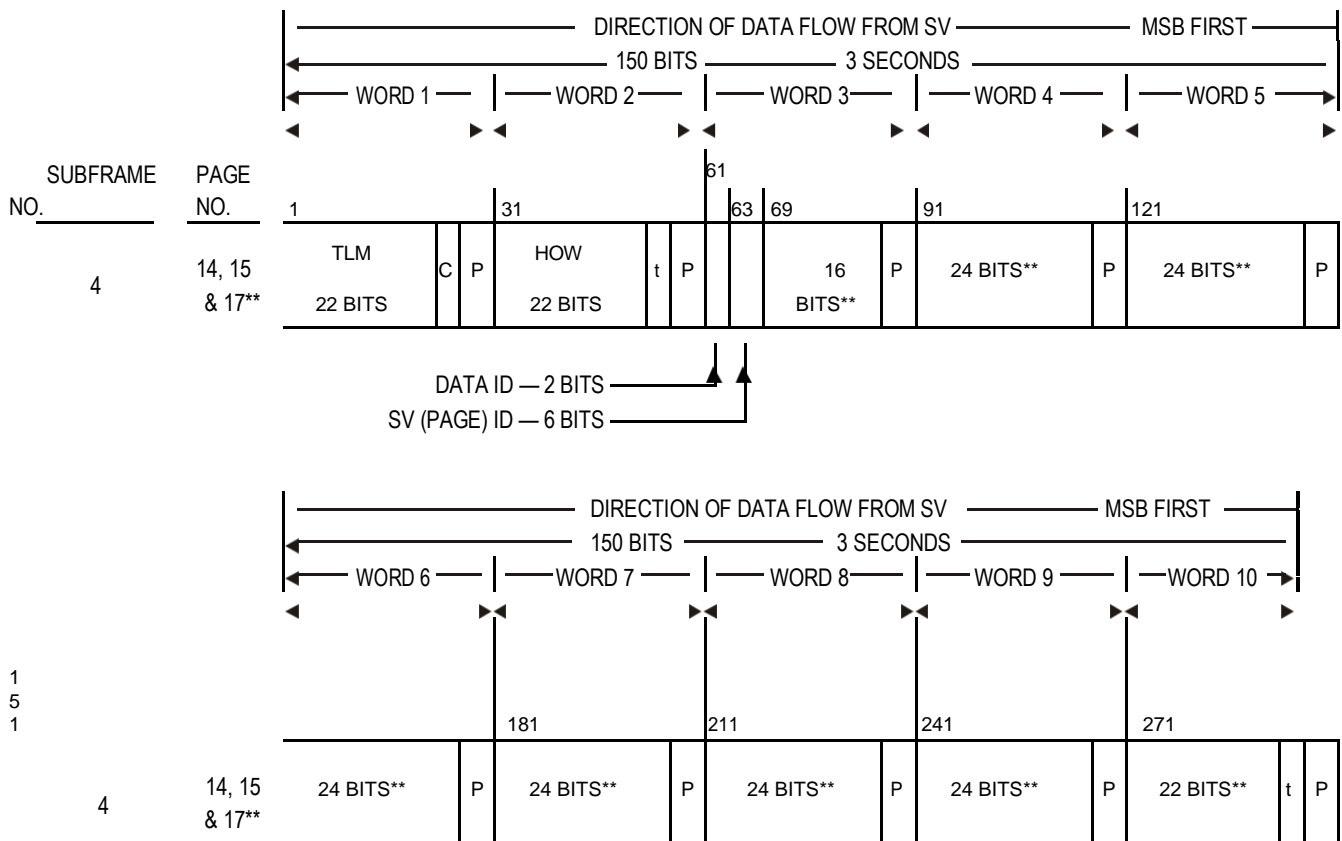

** THE INDICATED PORTIONS OF WORDS 3 THROUGH 10 OF PAGES 14 AND 15 ARE RESERVED FOR SYSTEM USE, WHILE THOSE OF PAGE 17 ARE RESERVED FOR SPECIAL MESSAGES

P = 6 PARITY BITS

t = 2 NON-INFORMATION BEARING BITS USED FOR PARITY COMPUTATION

C = TLM BITS 23 AND 24 WHICH ARE RESERVED

Figure B-6. Data format (11 of 11)

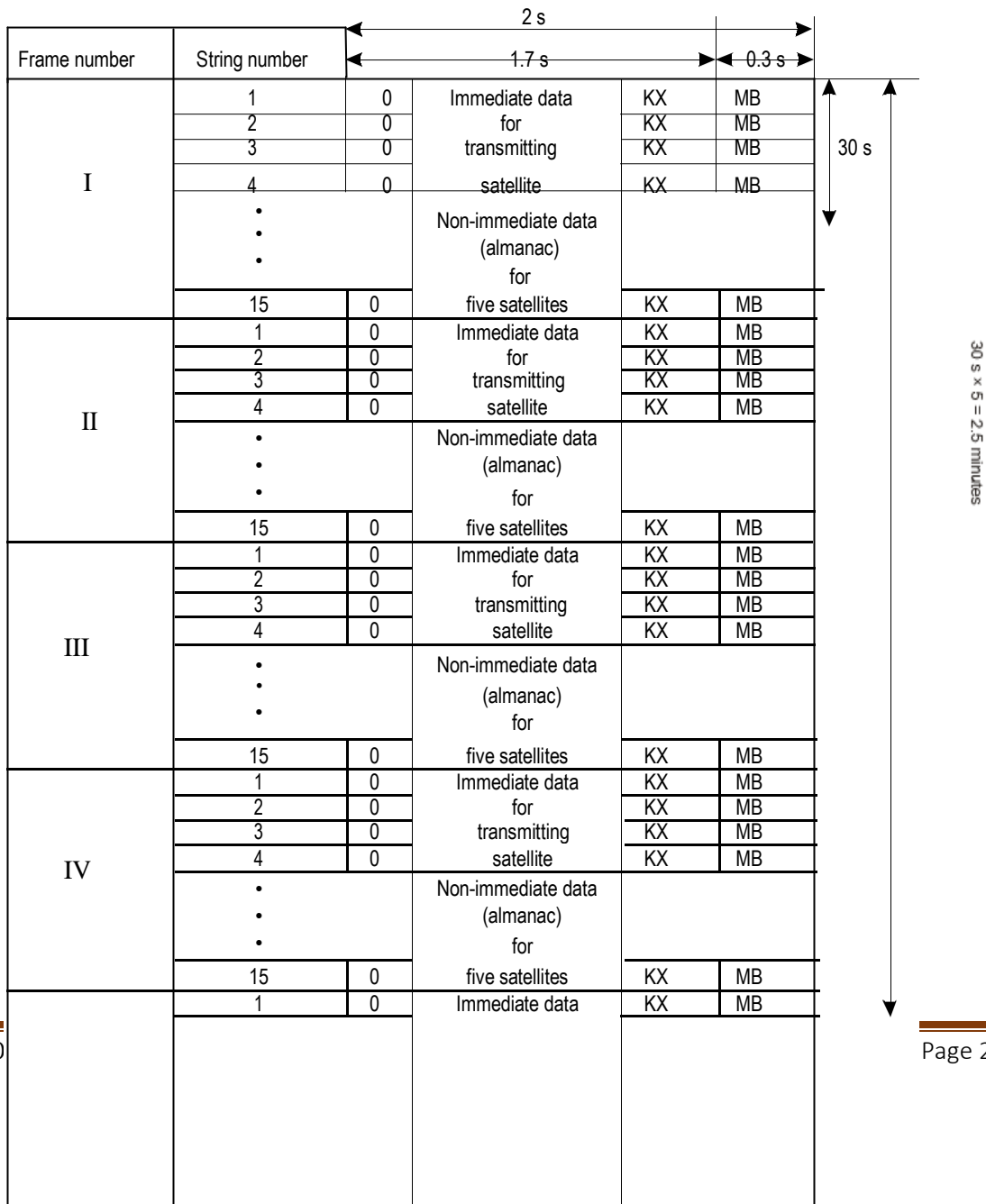

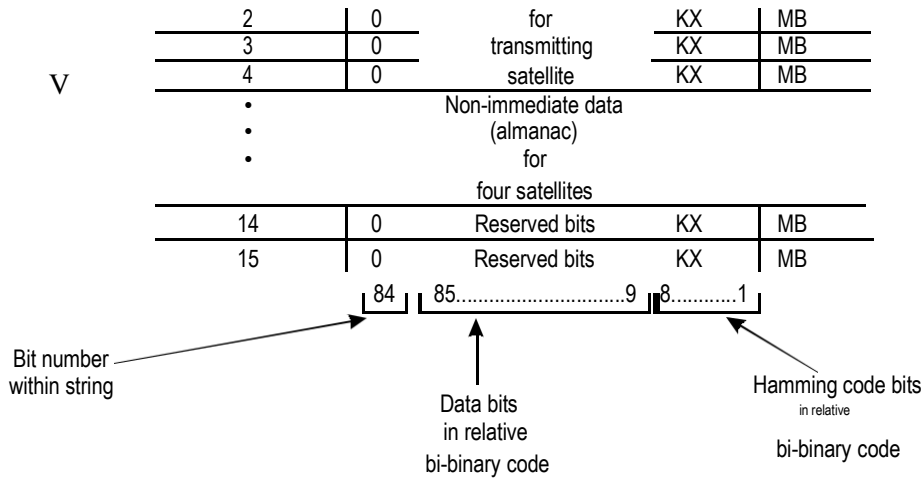

Figure B-7. Superframe structure

17/11/23/06
No. 86

APP B-142

String No.

(P2)	1	m	4	2	2	P1	t _k	12	x'(t)	n _b	24	x''(t)	n _b	27	x(t)	n _b	27	KX	8	MB
	2	m	4	3	1	B _n	t _b	7	y'(t)	n _b	24	y''(t)	n _b	27	y(t)	n _b	27	KX	8	MB
(P3)	3	m	4	1	1	Y _n (t _b)		11	z _n '(t _b)		24	z _n ''(t _b)		27	z _n (t _b)		27	KX	8	MB
	4	m	4	2	2	T _n (t _b)		22	ΔT _n	E _n	5	*	P ₄	T _T *	N _T	n	M	KX	8	MB
(C _n)	5	m	4	4	11	N ^A	T _c	32	T _{GPS}	1	1	1	1	1	1	1	1	KX	8	MB
	6	m	4	2	5	M ^A _n	n ^A	10	T ^A _{λ_n}	λ ^A _n	21	i ^A _n	18	ε ^A _n	15			KX	8	MB
	7	m	4	16	21	ω ^A _n	T ^A _{λ_n}	21	ΔT ^A _n	ΔT ^A _n	22	ΔT ^A _n	7	H ^A _n	5	1	1	KX	8	MB
	8	m	4	2	5	M ^A _n	n ^A	10	T ^A _{λ_n}	λ ^A _n	21	i ^A _n	18	ε ^A _n	15			KX	8	MB
	9	m	4	16	21	ω ^A _n	T ^A _{λ_n}	21	ΔT ^A _n	ΔT ^A _n	22	ΔT ^A _n	7	H ^A _n	5	1	1	KX	8	MB
	10	m	4	2	5	M ^A _n	n ^A	10	T ^A _{λ_n}	λ ^A _n	21	i ^A _n	18	ε ^A _n	15			KX	8	MB
	11	m	4	16	21	ω ^A _n	T ^A _{λ_n}	21	ΔT ^A _n	ΔT ^A _n	22	ΔT ^A _n	7	H ^A _n	5	1	1	KX	8	MB
	12	m	4	2	5	M ^A _n	n ^A	10	T ^A _{λ_n}	λ ^A _n	21	i ^A _n	18	ε ^A _n	15			KX	8	MB
	13	m	4	16	21	ω ^A _n	T ^A _{λ_n}	21	ΔT ^A _n	ΔT ^A _n	22	ΔT ^A _n	7	H ^A _n	5	1	1	KX	8	MB
	14	m	4	2	5	M ^A _n	n ^A	10	T ^A _{λ_n}	λ ^A _n	21	i ^A _n	18	ε ^A _n	15			KX	8	MB
	15	m	4	16	21	ω ^A _n	T ^A _{λ_n}	21	ΔT ^A _n	ΔT ^A _n	22	ΔT ^A _n	7	H ^A _n	5	1	1	KX	8	MB

* Reserved bits within frame

Note.— Data content, definitions and explanations of parameters are given in 3.2.1.3 and 3.2.1.4. Additional data transmitted by GLONASS-M are highlighted in this figure.

Figure B-8.

Frame structure (frames 1 to 4)

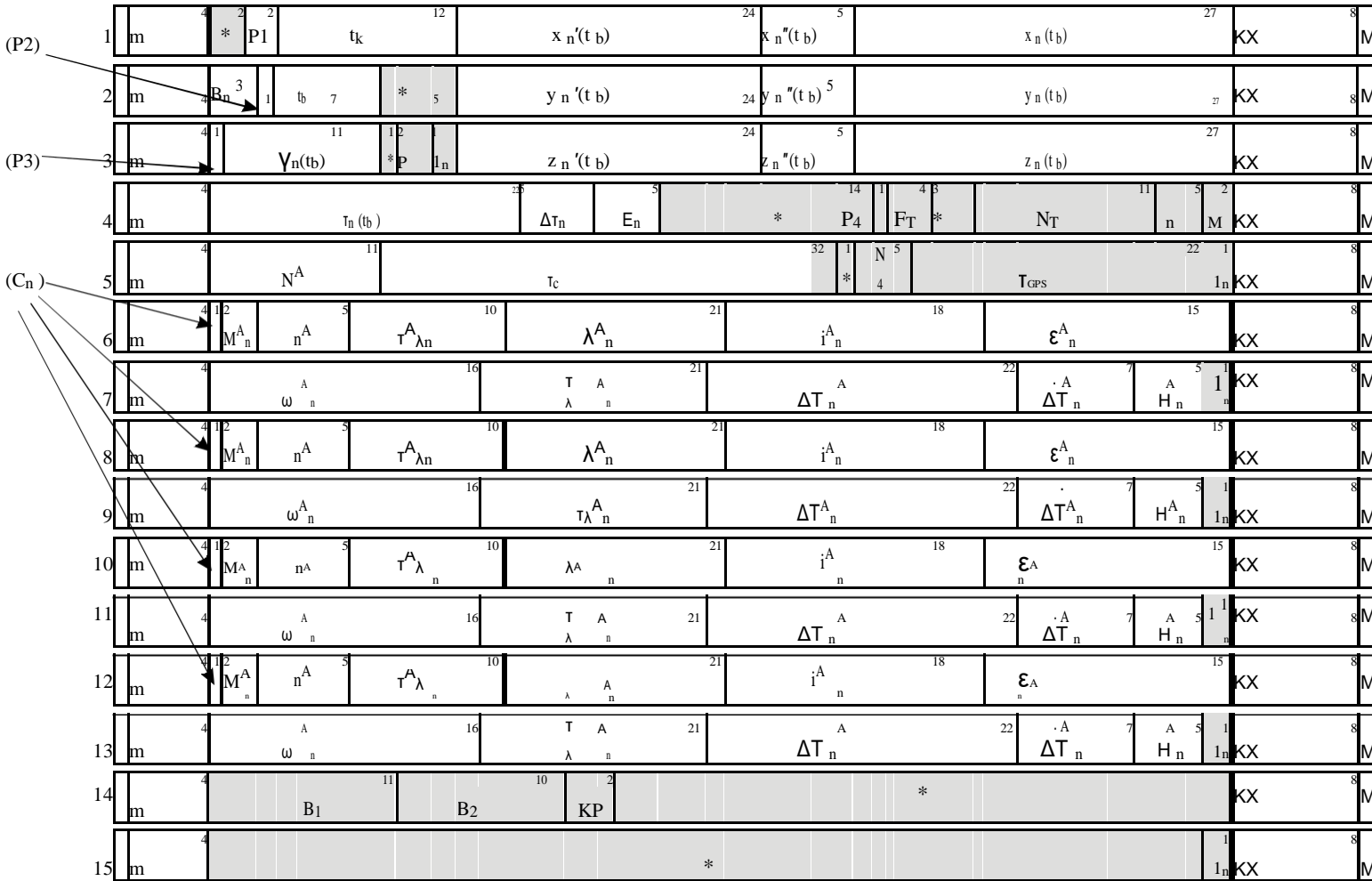

* Reserved bits within frame

Note.— Data content, definitions and explanations of parameters are given in 3.2.1.3 and 3.2.1.4. Additional data transmitted by GLONASS-M are highlighted in this figure.

Figure B-9.

Frame structure (frame 5)

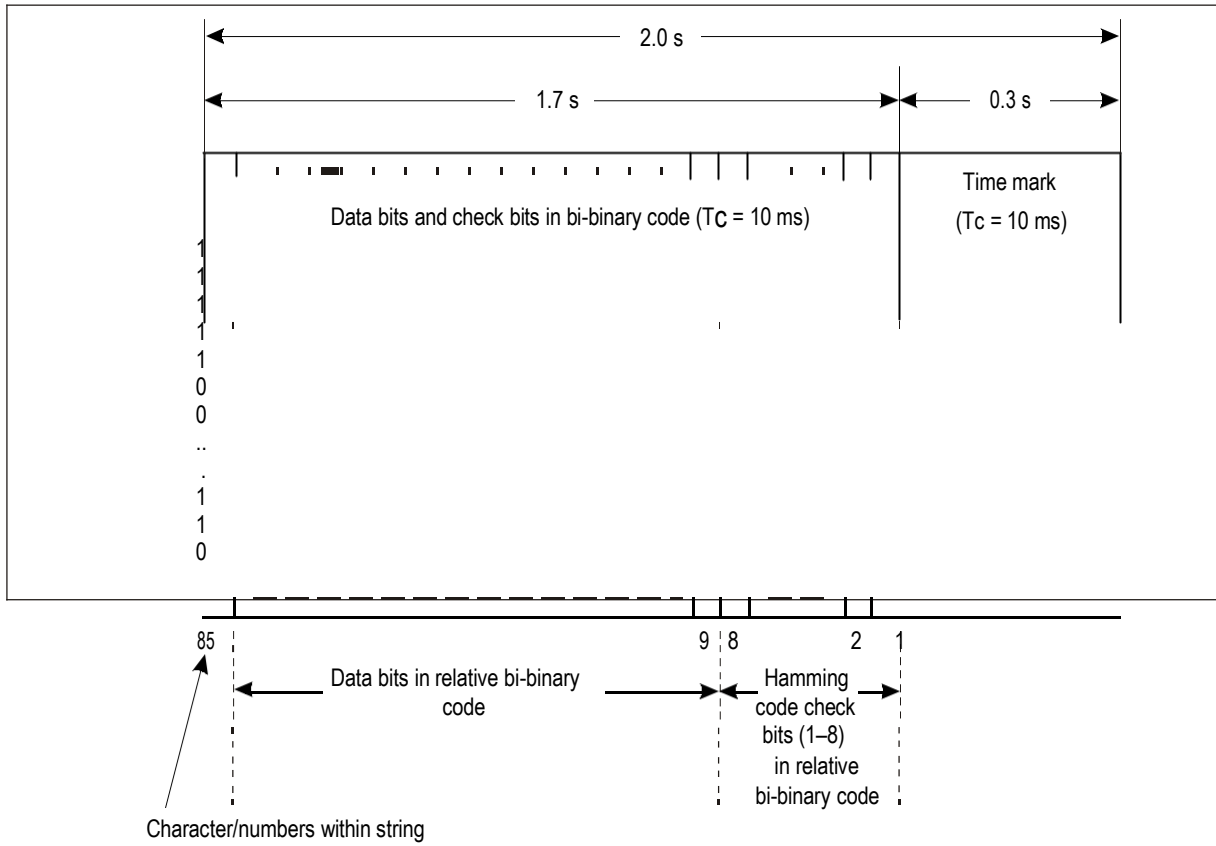

Note.— T_c = time duration for each chip

Figure B-10. Data string structure

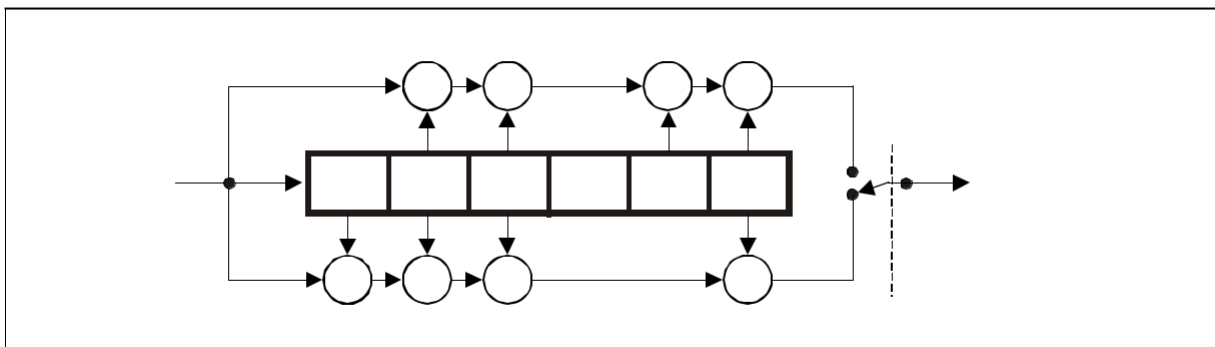

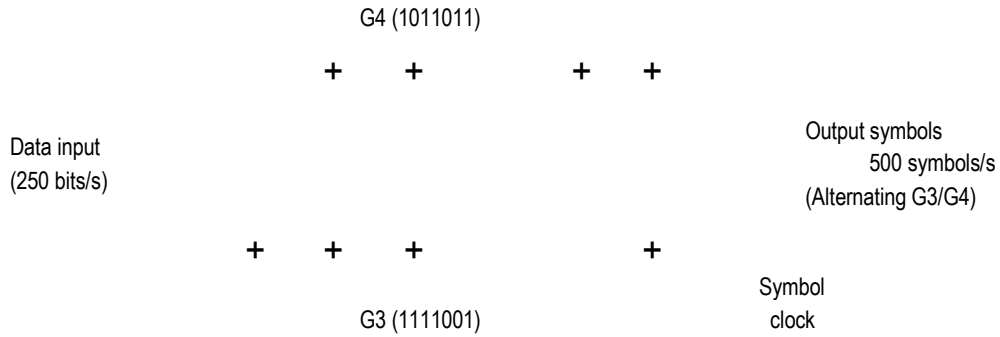

Figure B-11. Convolutional encoding

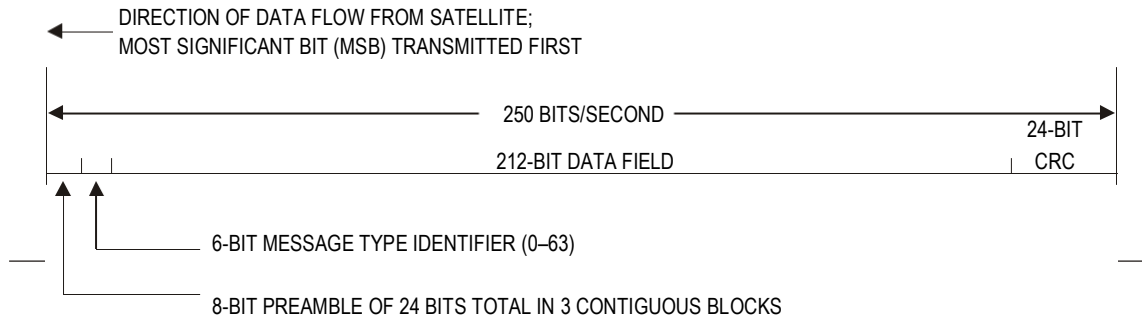

Figure B-12. Data block format

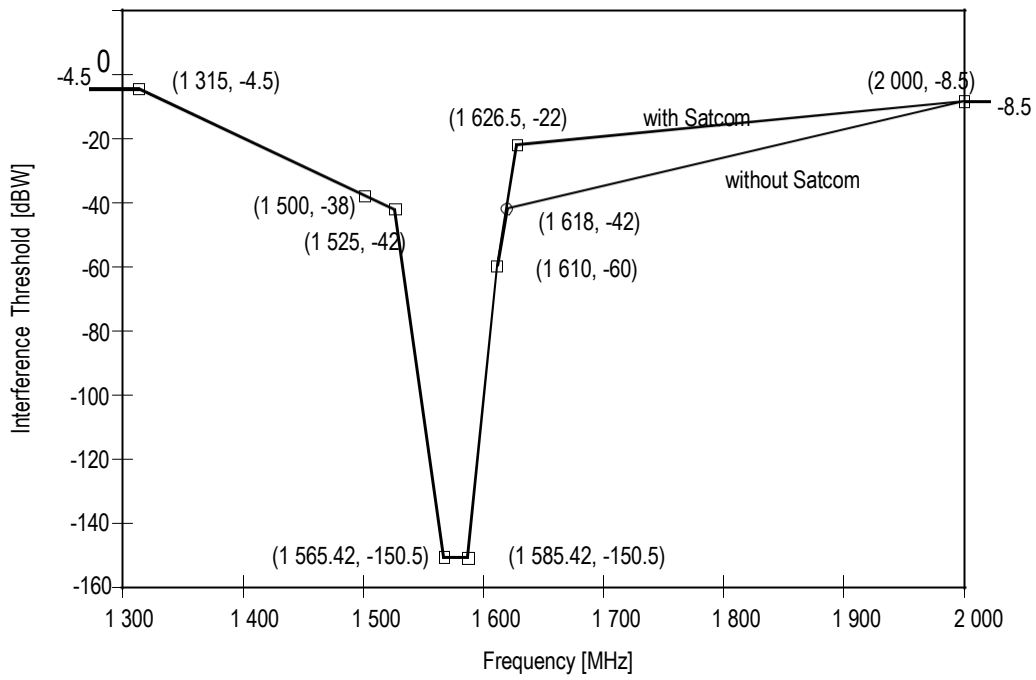

Figure B-15. CW interference thresholds for GPS and SBAS receivers used for precision approach

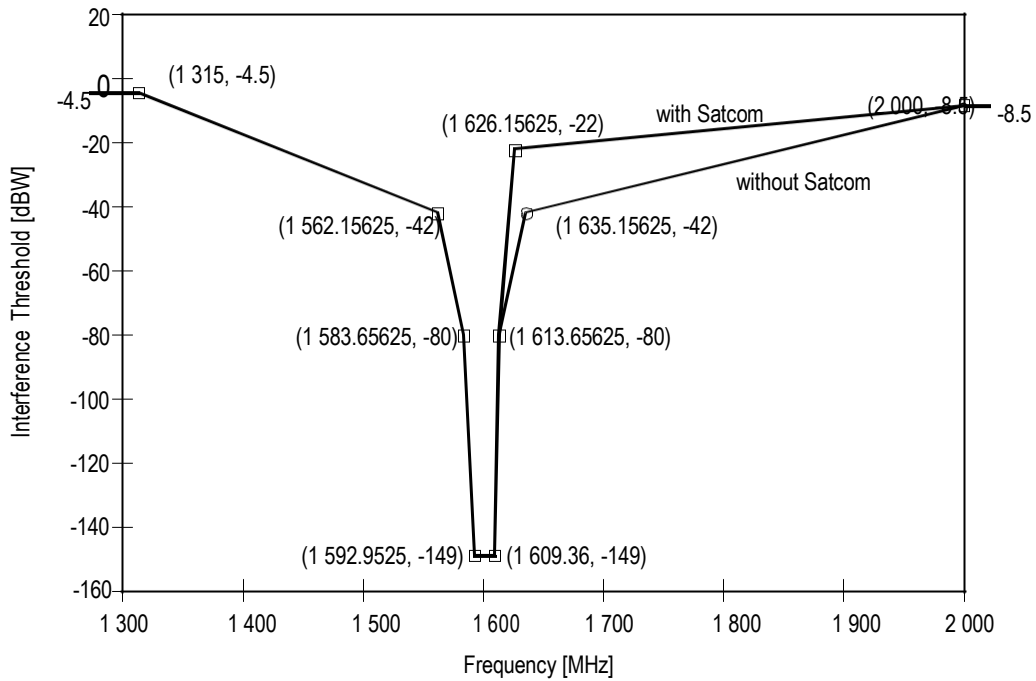

Figure B-16. CW interference thresholds for GLONASS receivers used for precision approach

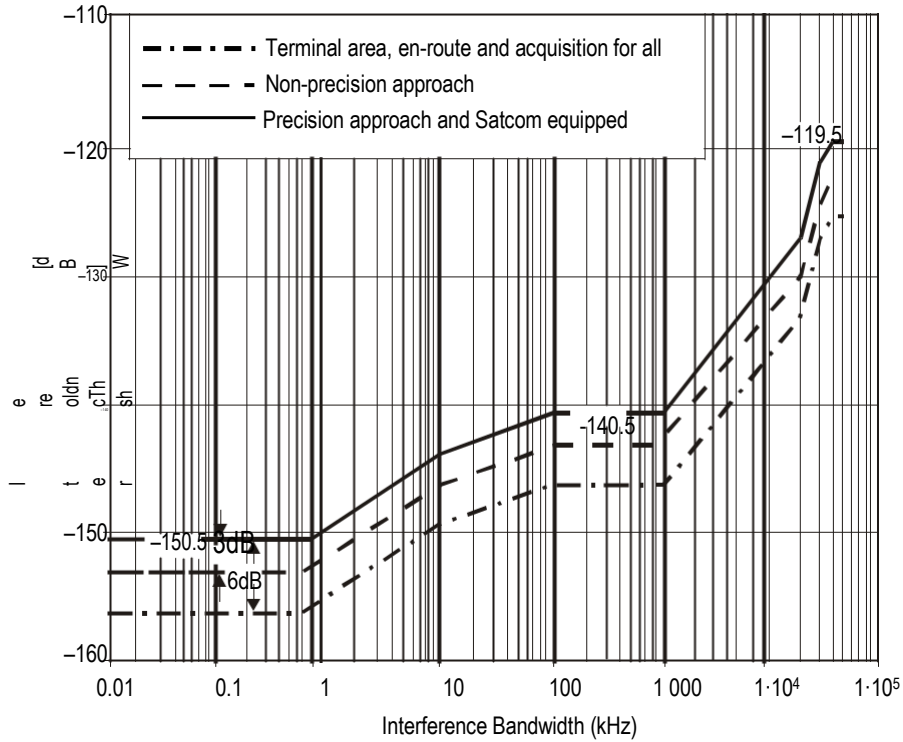

Figure B-17. Interference thresholds versus bandwidth for GPS and SBAS receivers

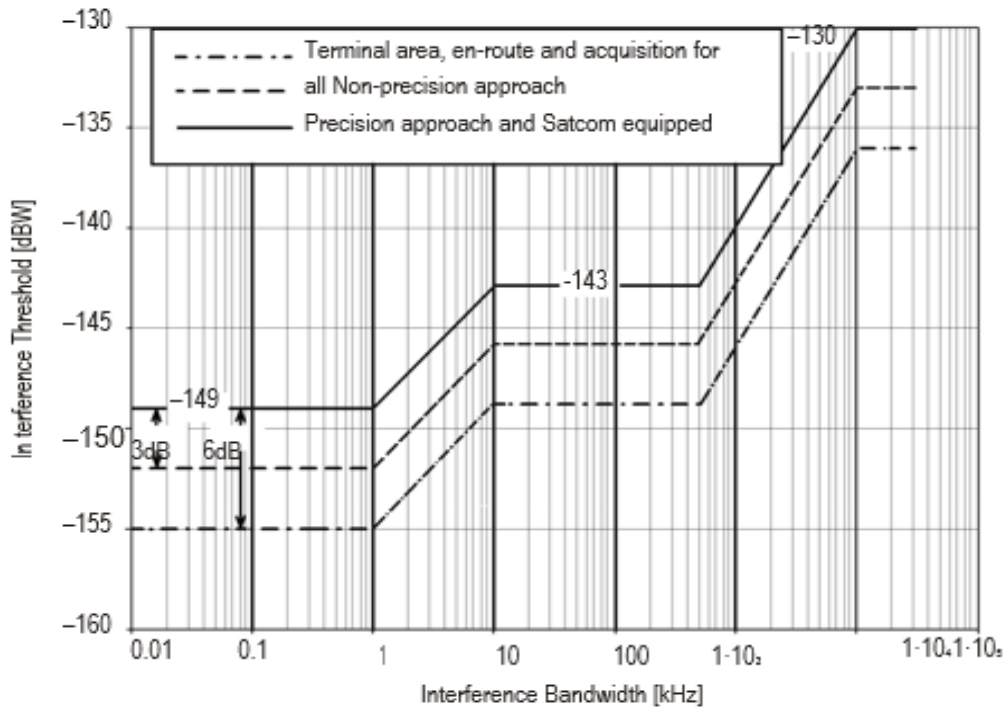

Figure B-18. Interference thresholds versus bandwidth for GLONASS

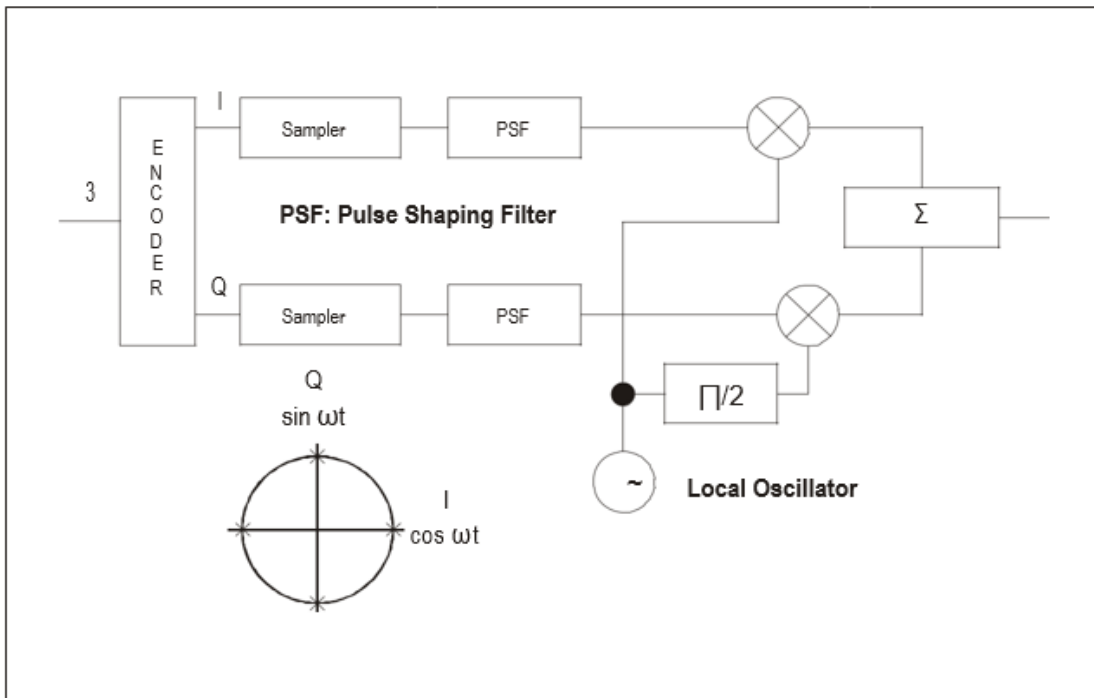

Figure B-19. Example data modulation

IS: 23.1.3.11 MICROWAVE LANDING SYSTEM (MLS) CHARACTERISTICS

Table A-1. Preamble timing*
(see Subpart 23.1.3.10.4.3.4)

Event	15.625 kHz Clock pulse (number)	Time (milliseconds)
Carrier acquisition (CW transmission)	0	0
Receiver reference time code		
I ₁ = 1	13	0.832
I ₂ = 1	1	0.896
I ₃ = 1	15	0.960
I ₄ = 0	16	1.024
I ₅ = 1	17	1.088**
Function identification		
I ₆	18	1.152
I ₇	19	1.216
I ₈	20	1.280
I ₉ (see 3.11.4.4.3.3)	21	1.344
I ₁₀	22	1.408
I ₁₁	23	1.472
I ₁₂	24	1.536
End preamble	25	1.600

* Applies to all functions transmitted.

** Reference time for receiver synchronization for all function timing.

Table A-2. Approach azimuth function timing
(see 3.11.4.3.4)

Event	15.625 kHz Clock pulse (number)	Time (milliseconds)
Preamble	0	0
Morse Code (see 3.11.4.6.2.1.2)	25	1.600
Antenna select	26	1.664
Rear OCI	32	2.048
Left OCI	34	2.176
Right OCI	36	2.304
TO test	38	2.432
TO scan*	40	2.560
Pause		8.760
Midscale point		9.060

FRO scan*	9.360
FRO test	15.560
End function (airborne)	15.688
End guard time; end function (ground)	15.900

* The actual commencement and completion of the TO and FRO scan transmissions are dependent on the amount of proportional guidance provided. The time slots provided will accommodate a maximum scan of plus or minus 62.0 degrees. Scan timing shall be compatible with accuracy requirements.

Table A-3. High rate approach azimuth and back azimuth function timing
(see 3.11.4.3.4)

Event time slot begins at

Event	15.625 kHz Clock pulse (number)	Time (milliseconds)
Preamble	0	0
Morse Code (see 3.11.4.6.2.1.2)	25	1.600
Antenna select	26	1.664
Rear OCI	32	2.048
Left OCI	34	2.176
Right OCI	36	2.304
TO test	38	2.432
TO scan*	40	2.560
Pause		6.760
Midscan point		7.060
FRO scan*		7.360
FRO test pulse		11.560
End function (airborne)		11.688
End guard time; end function (ground)		11.900

* The actual commencement and completion of the TO and FRO scan transmissions are dependent on the amount of proportional guidance provided. The time slots provided will accommodate a maximum scan of plus or minus 42.0 degrees. Scan timing shall be compatible with accuracy requirements.

Table A-4. Approach elevation function timing
(see 3.11.4.3.4)

Event time slot begins at

Event	15.625 kHz Clock pulse (number)	Time (milliseconds)
Preamble	0	0
Processor pause	25	1.600
OCI	27	1.728
TO scan*	29	1.856
Pause		3.406
Midscan point		3.606
FRO scan*		3.806
End function (airborne)		5.356
End guard time; end function (ground)		5.600

* The actual commencement and completion of the TO and FRO scan transmissions are dependent on the amount of proportional guidance provided. The time slots provided will accommodate a maximum scan of minus 1.5 degrees to plus 29.5 degrees. Scan timing shall be compatible with accuracy requirements.

Table A-5. Flare function timing
(see 3.11.4.3.4)

Event time slot begins at

Event	15.625 kHz Clock pulse (number)	Time (milliseconds)
Preamble	0	0
Processor pause	25	1.600
TO scan*	29	1.856
Pause		3.056
Midscan point		3.456
FRO scan*		3.856
End function (airborne)		5.056
End guard time; end function (ground)		5.300

* The actual commencement and completion of the TO and FRO scan transmissions are dependent on the amount of proportional guidance provided. The time slots provided will accommodate a maximum scan of minus 2.0 degrees to plus 10.0 degrees. Scan timing shall be compatible with accuracy requirements.

Table A-6. Basic data function timing
(see 3.11.4.3.4)

Event time slot begins at

Event	15.625 kHz Clock pulse (number)	Time (milliseconds)
Preamble	0	0
Data transmission (Bits I ₁₃ - I ₃₀)	24	1.600
Parity transmission (Bits I ₃₁ - I ₃₂)	43	2.752
End function (airborne)	45	2.880
End guard time; end function (ground)		3.100

Table A-7. Basic data
(see 3.11.4.8.2.1)

Word	Data content	Maximum time between transmissions (seconds)	Bits used	Range of values	Least significant bit	Bit number
1	PREAMBLE Approach azimuth antenna to	1.0	12 6	see Note 10 0 m to 6 300 m	100 m	I ₁₋₁₂ I ₁₃₋₁₈

	threshold distance					I - I _{19 - 23}
	Approach azimuth proportional guidance sector negative limit	5	0° to 60° (see Note 11)	2°		I - I _{24 - 28}
	Approach azimuth proportional guidance sector positive limit	5	0° to 60° (see Note 11)	2°		I ₂₉
	Clearance signal type	1	see Note 9			I ₃₀
	SPARE	1	see Note 12			I - I _{31 - 32}
	PARITY	2	see Note 1			
2	PREAMBLE	0.16	12	see Note 10		I _{1 - I12}
	Minimum glide path	7	2° to 14.7°	0.1°		I - I _{13 - 19}
	Back azimuth status	1	see Note 2			I ₂₀
	DME status	2	see Note 7			I - I _{21 - 22}
	Approach azimuth status	1	see Note 2			I ₂₃
	Approach elevation status	1	see Note 2			I ₂₄
	SPARE	6	see Notes 6 and 12			I - I _{25 - 30}
	PARITY	2	see Note 1			I - I _{31 - 32}

Word	Data content	Maximum time between transmissions (seconds)	Bits used	Range of values	Least significant bit	Bit number
3	PREAMBLE	1.0	12	see Note 10		I _{1 - I12}
	Approach azimuth beamwidth		3	0.5° to 4° (See Note 8)	0.5°	I - I _{13 - 15}
	Approach elevation beamwidth		3	0.5° to 2.5° (See Note 8)	0.5°	I - I _{16 - 18}
	DME distance		9	0 m to 6 387.5 m	12.5 m	I - I _{19 - 27}
	SPARE		3	see Note 12		I - I _{28 - 30}
	PARITY		2	see Note 1		I - I _{31 - 32}
4	PREAMBLE	1.0	12	see Notes 4 and 10		I _{1 - I12}
	Approach azimuth magnetic Orientation		9	0° to 359°	1°	I - I _{13 - 21}
	Back azimuth magnetic orientation		9	0° to 359°	1°	I - I _{22 - 30}
	PARITY		2	see Note 1		I - I _{31 - 32}

5	PREAMBLE	1.0	12	see Notes 5 and 10	I ₁ - I ₁₂
	Back azimuth proportional guidance sector negative limit		5	0° to 40° (see Note 11)	2° I ₁₃ - I ₁₇
	Back azimuth proportional guidance sector positive limit		5	0° to 40° (see Note 11)	2° I ₁₈ - I ₂₂
	Back azimuth beamwidth		3	0.5° to 4.0° (see Note 8)	0.5° I ₂₃ - I ₂₅
	Back azimuth status		1	see Note 2	I ₂₆
	SPARE		4	see Notes 3 and 12	I ₂₇ - I ₃₀
	PARITY		2	see Note 1	I ₃₁ - I ₃₂
6	PREAMBLE MLS ground equipment Identification	1.0	12	see Notes 4 and 10 Letters A to Z	I ₁ - I ₁₂
Character 2			6		I ₁₃ - I ₁₈
Character 3			6		I ₁₉ - I ₂₄
Character 4			6		I ₂₅ - I ₃₀
PARITY			2	see Note 1	I ₃₁ - I ₃₂

NOTES.—

1. Parity bits I₃₁ and I₃₂ are chosen to satisfy the equations:
 $I_{13} + I_{14} \dots + I_{29} + I_{30} + I_{31} = \text{ODD}$
 $I_{14} + I_{16} + I_{18} \dots + I_{28} + I_{30} + I_{32} = \text{ODD}.$
2. Coding for status bit:
 0 = function not radiated, or radiated in test mode (not reliable for navigation);
 1 = function radiated in normal mode (in Basic data word 2 the back azimuth status also indicates that back azimuth transmission is to follow).
3. These bits are reserved for future applications. One possible application is to define the back azimuth deviation scale factor.
4. Basic data words 4 and 6 are transmitted in both approach azimuth and back azimuth coverages if back azimuth guidance is provided, while retaining the maximum specified time between transmissions in each coverage sector.
5. Basic data word 5 is transmitted in both approach azimuth and back azimuth coverages if back azimuth guidance is provided, while retaining the maximum specified time between transmissions in each coverage sector.
6. These bits are reserved for future applications requiring high transmission rates.
7. Coding for I₂₁ and I₂₂:
 I₂₁ I₂₂
 0 ODME transponder inoperative or not available
 1 0Only IA mode or DME/N available
 0 1FA mode, Standard 1, available
 1 1FA mode, Standard 2, available
8. The value coded is the actual beamwidth (as defined in Chapter 3, 3.11.1) rounded to the nearest 0.5 degree.
9. Code for I₂₉ is:
 0 = pulse clearance signal
 1 = scanning clearance signal.
10. The 12 data bits of the preamble are preceded by an 0.832 millisecond interval (13 clock pulses) of CW for carrier acquisition (see Table A-1).
11. The scan limits are greater than the proportional guidance sector limits shown in Basic data words 1 and 5 as described in 3.11.4.5.1.
12. All spare bits are set to ZERO.

Table A-8. Auxiliary data function timing
(see 3.11.4.3.4)

Event time slot begins at

Event	15.625 kHz Clock pulse (number) (milliseconds)	Time
Preamble	0	0
Address transmission (Bits I ₁₃ - I ₂₀)	25	1.600
Data transmission (Bits I ₂₁ - I ₆₉)	33	2.112
Parity transmission (Bits I ₇₀ - I ₇₆)	82	5.248
End function (airborne)	89	5.696
End guard time; end function (ground)		5.900

Table A-9. Auxiliary data words address codes

No.	I ₁₃	I ₁₄	I ₁₅	I ₁₆	I ₁₇	I ₁₈	I ₁₉	I ₂₀	No.	I ₁₃	I ₁₄	I ₁₅	I ₁₆	I ₁₇	I ₁₈	I ₁₉	I ₂₀
1	0	0	0	0	0	1	1	1	33	1	0	0	0	0	1	0	1
2	0	0	0	0	1	0	1	0	34	1	0	0	0	1	0	0	0
3	0	0	0	0	1	1	0	1	35	1	0	0	0	1	1	1	1
4	0	0	0	1	0	0	1	1	36	1	0	0	1	0	0	0	1
5	0	0	0	1	0	1	0	0	37	1	0	0	1	0	1	1	0
6	0	0	0	1	1	0	0	1	38	1	0	0	1	1	0	1	1
7	0	0	0	1	1	1	1	0	39	1	0	0	1	1	1	0	0
8	0	0	1	0	0	0	1	0	40	1	0	1	0	0	0	0	0
9	0	0	1	0	0	1	0	1	41	1	0	1	0	0	1	1	1
10	0	0	1	0	1	0	0	0	42	1	0	1	0	1	0	1	0
11	0	0	1	0	1	1	1	1	43	1	0	1	0	1	1	0	1
12	0	0	1	1	0	0	0	1	44	1	0	1	1	0	0	1	1
13	0	0	1	1	0	1	1	0	45	1	0	1	1	0	1	0	0
14	0	0	1	1	1	0	1	1	46	1	0	1	1	1	0	0	1
15	0	0	1	1	1	1	0	0	47	1	0	1	1	1	1	1	0
16	0	1	0	0	0	0	1	1	48	1	1	0	0	0	0	0	1
17	0	1	0	0	0	1	0	0	49	1	1	0	0	0	1	1	0
18	0	1	0	0	1	0	0	1	50	1	1	0	0	1	0	1	1
19	0	1	0	0	1	1	1	0	51	1	1	0	0	1	1	0	0
20	0	1	0	1	0	0	0	0	52	1	1	0	1	0	0	1	0
21	0	1	0	1	0	1	1	1	53	1	1	0	1	0	1	0	1
22	0	1	0	1	1	0	1	0	54	1	1	0	1	1	0	0	0
23	0	1	0	1	1	1	0	1	55	1	1	0	1	1	1	1	1
24	0	1	1	0	0	0	0	1	56	1	1	1	0	0	0	1	1
25	0	1	1	0	0	1	1	0	57	1	1	1	0	0	1	0	0
26	0	1	1	0	1	0	1	1	58	1	1	1	0	1	0	0	1
27	0	1	1	0	1	1	0	0	59	1	1	1	0	1	1	1	0
28	0	1	1	1	0	0	1	0	60	1	1	1	1	0	0	0	0
29	0	1	1	1	0	1	0	1	61	1	1	1	1	0	1	1	1
30	0	1	1	1	1	0	0	0	62	1	1	1	1	1	0	1	0
31	0	1	1	1	1	1	1	1	63	1	1	1	1	1	1	0	1
32	1	0	0	0	0	0	1	0	64	0	0	0	0	0	0	0	0

Note.— Parity bits I₁₉ and I₂₀ are chosen to satisfy the equations: I₁₃ + I₁₄ + I₁₅

+ I₁₆ + I₁₇ + I₁₈ + I₁₉ = EVEN I₄ +

I₁₆ + I₁₈ + I₂₀ = EVEN

Table A-10. Auxiliary data
(see 3.11.4.8.3.1)

Word	Data content	Type of data	Maximum time between transmissions (seconds)	Bits used	Range of values	Least significant bit	Bit number
A1	PREAMBLE	digital	1.0	12	see Note 6		I ₁ - I ₁₂
	Address			8			I ₁₃ - I ₂₀
	Approach azimuth antenna offset			10	-511 m to +511 m (see Note 3)	1 m	I ₂₁ - I ₃₀
	Approach azimuth antenna to MLS datum point distance			13	0 m to 8 191 m	1 m	I ₃₁ - I ₄₃
	Approach azimuth alignment with runway centre line			12	-20.47° to +20.47° (see Notes 3 and 7)	0.01°	I ₄₄ - I ₅₅
	Approach azimuth antenna coordinate system			1	See Note 2		I ₅₆
	Approach azimuth antenna height			7	-63 m to +63 m (see Note 3)	1 m	I ₅₇ - I ₆₃
	SPARE			6	See Note 8		I ₆₄ - I ₆₉
PARITY			7	See Note 1		I ₇₀ - I ₇₆	
A2	PREAMBLE	digital	1.0	12	See Note 6		I ₁ - I ₁₂
	Address			8			I ₁₃ - I ₂₀
	Approach elevation antenna offset			10	-511 m to +511 m (see Note 3)	1 m	I ₂₁ - I ₃₀
	MLS datum point to threshold distance			10	0 m to 1 023 m	1 m	I ₃₁ - I ₄₀
	Approach elevation antenna height			7	-6.3 m to +6.3 m (see Note 3)	0.1 m	I ₄₁ - I ₄₇
	MLS datum point elevation			13	-4 095 m to +4 095 m (see Note 3)	1 m	I ₄₈ - I ₆₀
	Runway threshold height			7	-6.3 m to +6.3 m (see Note 3)	0.1 m	I ₆₁ - I ₆₇
	SPARE			2	See Note 8		I ₆₈ - I ₆₉
PARITY			7	See Note 1		I ₇₀ - I ₇₆	

Word	Data content	Type of data	Maximum time between transmissions (seconds)	Bits used	Range of values	Least significant bit	Bit number
A3	PREAMBLE (see Note 4)	digital	1.0	12	See Note 6		I ₁ - I ₁₂
	Address			8			I ₁₃ - I ₂₀
	DME offset			12	-2 047 m to +2 047 m (see Note 3)	1 m	I ₂₁ - I ₃₂
	DME to MLS datum point distance			14	-8 191 m to +8 191 m (see Note 3)	1 m	I ₃₃ - I ₄₆
	DME antenna height			7	-63 m to +63 m (see Note 3)	1 m	I ₄₇ - I ₅₃
	Runway stop-end distance			14	0 m to 16 383 m	1 m	I ₅₄ - I ₆₇
	SPARE			2	See Note 8		I ₆₈ - I ₆₉
	PARITY			7	See Note 1		I ₇₀ - I ₇₆
A4	PREAMBLE (see Note 5)	digital	1.0	12	See Note 6		I ₁ - I ₁₂
	Address			8			I ₁₃ - I ₂₀
	Back azimuth antenna offset			10	-511 m to +511 m (see Note 3)	1 m	I ₂₁ - I ₃₀
	Back azimuth to MLS datum point distance			11	0 m to 2 047 m	1 m	I ₃₁ - I ₄₁
	Back azimuth alignment with runway centre line			12	-20.47° to +20.47° (see Notes 3 and 7)	0.01°	I ₄₂ - I ₅₃
	Back azimuth antenna coordinate system			1	See Note 2		I ₅₄
	Back azimuth antenna height			7	-63 m to +63 m (see Note 3)	1 m	I ₅₅ - I ₆₁
	SPARE			8	See Note 8		I ₆₂ - I ₆₉
	PARITY			7	See Note 1		I ₇₀ - I ₇₆

NOTES.—

- Parity bits I₇₀ to I₇₆ are chosen to satisfy the equations which follow.

For bit I₇₀

$$\text{EVEN} = (I_{13} + \dots + I_{18}) + I_{20} + I_{22} + I_{24} + I_{25} + I_{28} + I_{29} + I_{31} + I_{32} + I_{33} + I_{35} + I_{36} + I_{38} + I_{41} + I_{44} + I_{45} + I_{46} + I_{50} + (I_{52} + \dots + I_{55}) + I_{58} + I_{60} + I_{64} + I_{65} + I_{70}$$

For bit I₇₁

$$\text{EVEN} = (I_{14} + \dots + I_{19}) + I_{21} + I_{23} + I_{25} + I_{26} + I_{29} + I_{30} + I_{32} + I_{33} + I_{34} + I_{36} + I_{37} + I_{39} + I_{42} + I_{45} + I_{46} + I_{47} + I_{51} + (I_{53} + \dots + I_{56}) + I_{59} + I_{61} + I_{65} + I_{66} + I_{71}$$

For bit I₇₂

$$\text{EVEN} = (I_{15} + \dots + I_{20}) + I_{22} + I_{24} + I_{26} + I_{27} + I_{30} + I_{31} + I_{33} + I_{34} + I_{35} + I_{37} + I_{38}$$

+ I40 + I43 + I46 + I47 + I48 + I52 + (I54 + ... + I57) + I60 + I62 + I66 + I67

+ I72 For bit I73

EVEN = (I16 + ... + I21) + I23 + I25 + I27 + I28 + I31 + I32 + I34 + I35 + I36 + I38 + I39

+ I41 + I44 + I47 + I48 + I49 + I53 + (I55 + ... + I58) + I61 + I63 + I67 + I68 + I73

For bit I74

EVEN = (I17 + ... + I22) + I24 + I26 + I28 + I29 + I32 + I33 + I35 + I36 + I37 I39 + I40

+ I42 + I45 + I48 + I49 + I50 + I54 + (I56 + ... + I59) + I62 + I64 + I68 + I69

+ I74 For bit I75

EVEN = (I13 + ... + I17) + I19 + I21 + I23 + I24 + I27 + I28 + I30 + I31 + I32 + I34 + I35 + I37

+ I40 + I43 + I44 + I45 + I49 + (I51 + ... + I54) + I57 + I59 + I63 + I64 + I69 + I75

For bit I76

EVEN = I13 + I14 + ... + I75 + I76

2. Code for antenna coordinate system is 0 = conical.

3. The convention for the coding of negative numbers is as follows: MSB is the sign bit:

0 = positive

1 = negative

Other bits represent the absolute value.

The convention for the antenna location is as follows:

As viewed from the MLS approach reference datum looking toward the MLS datum point, a positive number represents a location to the right of the runway centre line (lateral offset) or above the runway (vertical offset), or towards the stop end of the runway (longitudinal distance). The convention for the alignment is as follows:

As viewed from above, a positive number represents clockwise rotation from the runway centre line to the respective zero-degree azimuth.

4. Data word A3 is transmitted in both approach azimuth and back azimuth coverages if back azimuth guidance is provided, while retaining the maximum specified time between transmissions in each coverage sector.

5. Data word A4 is transmitted in both approach azimuth and back azimuth coverages if back azimuth guidance is provided, while retaining the maximum specified time between transmissions in each coverage sector.

6. The 12 data bits of the preamble are preceded by an 0.832 millisecond interval (13 clock pulses) of CW for carrier acquisition (see Table A-1).

7. See Table A-12 for data words B42 and B43 which are defined for applications that require azimuth antenna rotation greater than the +20.47° supported by the data items in A1, for azimuth, and A4, for back azimuth. At a facility with the approach azimuth rotation greater than +20.47°, B42 is transmitted in place of A1. At a facility with the back azimuth rotation greater than +20.47°, B43 is transmitted in place of A4.

8. All spare bits are set to ZERO.

Table A-11. Definitions of auxiliary data B items
(see 3.11.4.8.3.2)

Note.— Definitions of auxiliary data B items supporting MLS/RNAV procedures are shown in Table A-13.

a) *Latitude of MLS datum point* shall be the latitude coordinate of the MLS datum point as defined by the World Geodetic System — 1984 (WGS-84) reference ellipsoid, coordinate system and associated datum.

b) *Longitude of the MLS datum point* shall be the longitude coordinate of the MLS datum point as defined by the same reference ellipsoid, coordinate system, and datum noted in item a).

c) *Vertical coordinate of the MLS datum point* shall be the vertical coordinate of the MLS datum point as defined by the same reference ellipsoid, coordinate system, and datum noted in item a).

Note.— Although WGS-84 has been approved as the ICAO Standard for geographical coordinates indicating latitude and longitude, introduction of vertical WGS-84 coordinates is pending. Until this introduction, an elevation referenced to mean sea level (msl) can continue to be used.

- d) *Approach azimuth true north orientation* shall represent the angle measured in the horizontal plane clockwise from True North to the zero-degree approach azimuth, originating from the approach azimuth antenna. The vertex of the measured angle shall be the approach azimuth antenna phase centre.
- e) *Runway visual range (RVR)* shall represent measurement of instrument RVR at touchdown zone, mid-point and stop end of the runway together with the trend indication, provided in accordance with Annex 3, Chapter 4.
- f) *Surface wind* shall represent wind speed and wind direction (magnetic), provided in accordance with Annex 3, Chapter 4.
- g) *Approach azimuth antenna offset* shall represent the minimum distance between the approach azimuth antenna phase centre and a vertical plane containing the runway centre line.
- h) *Approach azimuth antenna to MLS datum point distance* shall represent the minimum distance between the approach azimuth antenna phase centre and the vertical plane perpendicular to the runway centre line and containing the MLS datum point.
- i) *Approach azimuth alignment with runway centre line* shall represent the minimum angle between the zero-degree approach azimuth and the runway centre line.
- j) *Approach azimuth antenna height* shall represent the vertical location of the antenna phase centre with respect to the MLS datum point.
- k) *Back azimuth antenna offset* shall represent the minimum distance between the back azimuth antenna phase centre and a vertical plane containing the runway centre line.
- l) *Back azimuth antenna to MLS datum point distance* shall represent the minimum distance between the back azimuth antenna and the vertical plane perpendicular to the runway centre line which contains the MLS datum point.
- m) *Back azimuth alignment with runway centre line* shall represent the minimum angle between the zero-degree back azimuth and the runway centre line.
- n) *Back azimuth antenna height* shall represent the vertical location of the antenna phase centre with respect to the MLS datum point.
- o) *Primary runway number* shall represent the primary runway number as defined in Part 14, Section 14.5.
- p) *Primary runway letter* shall represent the primary runway letter as defined in Part 14, Section 14.5, where used to differentiate between parallel runways.
- q) *Secondary runway number* shall represent the secondary runway number as defined in Part 14, subpart 14.5.
- r) *Secondary runway letter* shall represent the secondary runway letter as defined in Part 14 Subpart 14.5, where used to differentiate between parallel runways.
- s) *Elevation guidance to secondary runway* shall indicate whether or not elevation guidance may be used to the secondary runway, and if so, whether it is directly usable as a raw angle or requires computed glide path.
- t) *Minimum glide path to secondary runway* shall represent the lowest angle of descent along the secondary runway centre line.
- u) *Approach azimuth alignment with secondary runway centre line* shall represent the minimum angle between the zero-degree approach azimuth and the secondary runway centre line.

- v) *Secondary runway threshold X coordinate* shall represent the minimum distance between the secondary runway threshold and the vertical plane perpendicular to the primary runway centre line containing the MLS datum point.
- w) *Secondary runway threshold Y coordinate* shall represent the minimum distance between the secondary runway threshold and the vertical plane containing the primary runway centre line.
- x) *Secondary runway threshold Z coordinate* shall represent the height of the secondary runway threshold above the MLS datum point.
- y) *Secondary runway threshold crossing height* shall represent the height above the secondary runway threshold at which the computed glide path crosses the threshold.
- z) *Virtual azimuth to secondary runway threshold distance* shall represent the distance to the secondary runway threshold from the point to be considered as the origin for lateral guidance to that runway.

Note.— This distance may be used by the MLS receiver in a manner similar to the approach azimuth antenna to threshold distance, to establish the lateral deviation scale factor.

Table A-12. Auxiliary data B
(see 3.11.4.8.3)

Word	Data content	Type of data	Maximum time between transmissions (seconds)	Bits used	Bits used	Least significant bit	Bit number
------	--------------	--------------	--	-----------	-----------	-----------------------	------------

Words B1 through B39: Time-invariant (fixed) data items supporting MLS/RNAV procedures (see Table A-15) Words B40 through B54: Other fixed data items

B40	PREAMBLE	digital	2.0	12	see Note6		I ₁ - I ₁₂
	Address			8			I ₁₃ - I ₂₀
	Latitude of MLS datum point			23	-324 000.0 arc seconds to +324 000.0 arc seconds (see Note2)	0.1 arc seconds	I ₂₁ - I ₄₃
	Longitude of MLS datum point			24	-648 000.0 arc seconds to +648 000.0 arc seconds (see Note2)	0.1 arc seconds	I ₄₄ - I ₆₇
	SPARE			2	see Note 9		I ₆₈ - I ₆₉
	PARITY			7	see Note1		I ₇₀ - I ₇₆
B41	PREAMBLE	digital	2.0	12	see Note6		I ₁ - I ₁₂
	Address			8			I ₁₃ - I ₂₀
	Vertical coordinate of MLS datum point			13	-4 095 m to +4 095 m (see Note2)	1 m	I ₂₁ - I ₃₃
	Approach azimuth True North orientation			16	0° to 359.99°	0.01°	I ₃₄ - I ₄₅
	SPARE			20			I ₅₀ - I ₆₉
	PARITY			7	see Note1		I ₇₀ - I ₇₆
B41	PREAMBLE	digital	2.0	12	see Note6		I ₁ - I ₁₂
	Address			8			I ₁₃ - I ₂₀
	Vertical coordinate of MLS datum point			13	-4 095 m to +4 095 m (see Note2)	1 m	I ₂₁ - I ₃₃
	Approach azimuth True North orientation			16	0° to 359.99°	0.01°	I ₃₄ - I ₄₅
	SPARE			20			I ₅₀ - I ₆₉
	PARITY			7	see Note1		I ₇₀ - I ₇₆
B42	PREAMBLE (see Note 5)	digital	1.0	12	see Note6		I ₁ - I ₁₂
	Address			8			I ₁₃ - I ₂₀
	Approach azimuth antenna offset			10	-511 m to +511 m (see Note2)	1 m	I ₂₁ - I ₃₀
	Approach azimuth antenna to MLS datum point distance			13	0 m to 8 191 m	1 m	I ₃₁ - I ₄₃
	Approach azimuth alignment with runway centre line			14	-81.91° to +81.91° (see Note2)	0.01°	I ₄₄ - I ₆₇
	Approach azimuth antenna height			7	-63 m to +63 m (see Note2)	1 m	I ₅₈ - I ₆₄
	SPARE			5	see Note 9		I ₆₅ - I ₆₉

Word	Data content	Type of data	Maximum time between transmissions (seconds)	Bits used	Bits used	Least significant bit	Bit number
	PARITY			7	see Note 1		I ₇₀ - I ₇₆

B43	PREAMBLE (see Notes 4 and 5)	digital	1.0	12	see Note 6		I1 - I12
	Address			8			I13 - I20
	Back azimuth antenna offset			10	-511 m to +511 m (see Note2)	1 m	I21 - I30
	Back azimuth antenna to MLS datum point distance			11	0 m to 2 047 m	1 m	I31 - I41
	Back azimuth alignment with runway centre line			14	-81.91° to +81.91° (see Note2)	0.01°	I42 - I55
	Back azimuth antenna height			7	-63 m to +63 m (see Note2)	1 m	I56 - I62
	SPARE			7	see Note 9		I63 - I69
	PARITY			7	see Note 1		I70 - I76
B44	PREAMBLE	digital	2.0	12	see Note 6		I1 - I12
	Address			8			I13 - I20
	Primary runway number			6	0 to 36 (see Note 10)		I21 - I26
	Primary runway letter			2	see Note 7		I27 - I28
	Secondary runway number			6	0 to 36 (see Note 10)		I29 - I34
	Secondary runway letter			2	see Note 7		I35 - I36
	Elevation guidance to secondary runway			2	see Note 8		I37 - I38
	Minimum glide path to secondary runway			7	2° to 14.7°	0.1°	I39 - I45
	Approach azimuth alignment with secondary runway centre line			16	±180.00°	0.01°	I46 - I61
	SPARE			8	see Note 9		I62 - I69
	PARITY			7	see Note 1		I70 - I76
B45	PREAMBLE	digital	2.0	12	see Note 6		I1 - I12
	Address			8			I13 - I20
	Secondary runway threshold X coordinate			15	±16 384 m	1 m	I21 - I35
	Secondary runway threshold Y coordinate			15	±16 384 m	1 m	I36- I50
Word	Data content	Type of data	Maximum time between transmissions (seconds)	Bits used	Bits used	Least significant bit	Bit number
	Secondary runway threshold			8	±127 m	1 m	I ₅₁ - I ₅₈

Z coordinate						I ₅₉ - I ₆₃
Secondary runway threshold crossing height	5	0 to 31 m	1 m			
Virtual azimuth to secondary runway threshold distance	6	0 to 6 300 m	100 m			I ₆₄ - I ₆₉
PARITY	7	see Note 1				I ₇₀ - I ₇₆
Words B55 through B64: Time-varying data items. (<i>Note.— Word B55 only is defined below.</i>)						
B55PREAMBLE	digital	10.0	12	see Note 6		I ₁ - I ₁₂
Address			8			I ₁₃ - I ₂₀
RVR (touchdown zone)			11	0 - 2 555 m (see Note 3)	5 m	I ₂₁ - I ₃₁
RVR (mid-point)			11	0 - 2 555 m (see Note 3)	5 m	I ₃₂ - I ₄₂
RVR (stop end)			11	0 - 2 555 m (see Note 3)	5 m	I ₄₃ - I ₅₃
Surface wind speed			7	0 - 127 kt	1 kt	I ₅₄ - I ₆₀
Surface wind direction (magnetic)			9	0 - 359°	1°	I ₆₁ - I ₆₉
PARITY			7	see Note 1		I ₇₀ - I ₇₆

NOTES.—

1. Parity bits I₇₀ to I₇₆ are chosen to satisfy the equations which follow.

For bit I₇₀

$$\text{EVEN} = (I_{13} + \dots + I_{18}) + I_{20} + I_{22} + I_{24} + I_{25} + I_{28} + I_{29} + I_{31} + I_{32} + I_{33} + I_{35} + I_{36} + I_{38} + I_{41} + I_{44} + I_{45} + I_{46} + I_{50} + (I_{52} + \dots + I_{55}) + I_{58} + I_{60} + I_{64} + I_{65} + I_{70}$$

For bit I₇₁

$$\text{EVEN} = (I_{14} + \dots + I_{19}) + I_{21} + I_{23} + I_{25} + I_{26} + I_{29} + I_{30} + I_{32} + I_{33} + I_{34} + I_{36} + I_{37} + I_{39} + I_{42} + I_{45} + I_{46} + I_{47} + I_{51} + (I_{53} + \dots + I_{56}) + I_{59} + I_{61} + I_{65} + I_{66} + I_{71}$$

For bit I₇₂

$$\text{EVEN} = (I_{15} + \dots + I_{20}) + I_{22} + I_{24} + I_{26} + I_{27} + I_{30} + I_{31} + I_{33} + I_{34} + I_{35} + I_{37} + I_{38} + I_{40} + I_{43} + I_{46} + I_{47} + I_{48} + I_{52} + (I_{54} + \dots + I_{57}) + I_{60} + I_{62} + I_{66} + I_{67} + I_{72}$$

For bit I₇₃

$$\text{EVEN} = (I_{16} + \dots + I_{21}) + I_{23} + I_{25} + I_{27} + I_{28} + I_{31} + I_{32} + I_{34} + I_{35} + I_{36} + I_{38} + I_{39} + I_{41} + I_{44} + I_{47} + I_{48} + I_{49} + I_{53} + (I_{55} + \dots + I_{58}) + I_{61} + I_{63} + I_{67} + I_{68} + I_{73}$$

For bit I₇₄

$$\text{EVEN} = (I_{17} + \dots + I_{22}) + I_{24} + I_{26} + I_{28} + I_{29} + I_{32} + I_{33} + I_{35} + I_{36} + I_{37} + I_{39} + I_{40} + I_{42} + I_{45} + I_{48} + I_{49} + I_{50} + I_{54} + (I_{56} + \dots + I_{59}) + I_{62} + I_{64} + I_{68} + I_{69} + I_{74}$$

For bit I₇₅

$$\text{EVEN} = (I_{13} + \dots + I_{17}) + I_{19} + I_{21} + I_{23} + I_{24} + I_{27} + I_{28} + I_{30} + I_{31} + I_{32} + I_{34} + I_{35} + I_{37} + I_{40} + I_{43} + I_{44} + I_{45} + I_{49} + (I_{51} + \dots + I_{54}) + I_{57} + I_{59} + I_{63} + I_{64} + I_{69} + I_{75}$$

For bit I₇₆

$$\text{EVEN} = I_{13} + I_{14} + \dots + I_{75} + I_{76}$$

2. The convention for the coding of negative numbers is as follows:

MSB is the sign bit:

0 = positive

1 = negative

Other bits represent the absolute value.

The convention for the antenna location is as follows:

As viewed from the MLS approach reference datum looking toward the MLS datum point, a positive number represents a location to the right of the runway centre line (lateral offset) or above the runway (vertical offset), or towards the stop end of the runway (longitudinal distance).

The convention for the alignment is as follows:

As viewed from above, a positive number represents clockwise rotation from the runway centre line to the respective zero-degree guidance radial.

The convention for geodetic coordinates is as follows:

A positive number represents a northern latitude or eastern longitude.

A negative number represents a southern latitude or western longitude.

3. The tenth and eleventh bits transmitted for each RVR value are used to provide trend information. The convention for coding is as follows:

Tenth bit	Eleventh bit	
Off	0	0
Decreasing	1	0
Equal	0	1
Increasing	1	1

4. When used, data word B43 is transmitted in both approach azimuth and back azimuth coverage sectors if back azimuth guidance is provided, while retaining the specified maximum time between transmissions in each area.

5. Data words B42 and B43 are defined for applications that require azimuth antenna rotation greater than the 20.47° supported by the data items in A1, for azimuth, and A4, for back azimuth. At a facility with approach azimuth rotation greater than 20.47°, B42 is transmitted in place of A1. At a facility with the back azimuth rotation greater than 20.47°, B43 is transmitted in place of A4.

6. The 12 data bits of the preamble are preceded by an 0.832 millisecond interval (13 clock pulses) of CW for carrier acquisition (see Table A-1).

7. The convention for coding is as follows:

0 = no letter

1 = R (right)

2 = C (centre)

3 = L (left)

8. The convention for coding is as follows:

0 = not provided

1 = raw elevation guidance

2 = computed glide path

3 = code not allowed

9. All spare bits are set to ZERO.

10. Runway number designation 0 is for heliport operations.

Table A-13. Definitions of auxiliary data B items concerning MLS/RNAV procedure database

(see 3.11.4.8.3.2)

- a) *Number of approach azimuth procedure descriptors* shall represent the total number of named approach and departure procedures for which procedure descriptor words are transmitted in the approach azimuth coverage sector.

Note.— Missed approaches are not counted, as they do not use procedure descriptor words. Computed centre line procedures to the primary runway are counted if a procedure descriptor is transmitted, even though associated waypoint data are not transmitted in auxiliary words B1 to B39.

- b) *Number of back azimuth procedure descriptors* shall represent the total number of named approach and departure procedures for which procedure descriptor words are transmitted in the back azimuth coverage sector.

Note.— Missed approaches are not counted, as they do not use procedure descriptor words.

- c) *Last approach azimuth database word* shall represent the address code of the last auxiliary data word within the range B1 to B39 which is transmitted in the approach azimuth coverage sector, as defined by bits I₁₃ to I₁₈ of that word.

- d) *First back azimuth database word* shall represent the address code of the first auxiliary data word within the range B1 to B39 which is transmitted in the back azimuth coverage sector, as defined by bits I₁₃ to I₁₈ of that word.
- e) *Approach azimuth CRC code* shall represent the coefficients of the cyclic redundancy check code for the approach azimuth procedure database.
- f) *Back azimuth CRC code* shall represent the coefficients of the cyclic redundancy check code for the back azimuth procedure database.
- g) *Word B42 transmitted* shall indicate whether auxiliary data word B42 is transmitted in lieu of word A1.
- h) *Word A4 transmitted* shall indicate whether auxiliary data word A4 is transmitted.
- i) *Word B43 transmitted* shall indicate whether auxiliary data word B43 is transmitted.
- j) *Back azimuth map/CRC indicator* shall indicate whether auxiliary data word B39 is employed as a back azimuth map/CRC word or as an approach azimuth waypoint data word.
- k) *Basic indicator* shall represent the name of the first flown waypoint in an approach procedure, or the last flown waypoint in a departure procedure. The name shall consist of five alpha characters coded in accordance with bits b₁ to b₅ of International Alphabet No. 5.
- l) *Validity indicator* shall represent the revision level of the approach or departure procedure. The validity indicator shall be a number from 1 to 9.
- m) *Route indicator* shall represent the route to or from the waypoint named by the basic indicator. The route indicator shall be a single alpha character coded in accordance with bits b₁ to b₅ of International Alphabet No. 5. The letters “I” and “O” shall not be used. Each of the 24 available route indicators shall be assigned not more than once within the combined set of approach azimuth and back azimuth procedure descriptor words.
- Note.— The restriction on the unique assignment of route indicators for MLS/RNAV operations is a departure from normal route assignment practice necessary to enhance the integrity of procedure selection and reduce pilot workload.*
- n) *Runway number* shall represent the runway number as defined in Annex 14, Volume I, Chapter 5.
- o) *Runway letter* shall represent the runway letter as defined in Annex 14, Volume I, Chapter 5, where used to differentiate between parallel runways.
- p) *Procedure type* shall indicate whether the procedure is an approach procedure or a departure procedure.
- q) *First waypoint index* shall represent the sequential position, within the approach azimuth database or back azimuth database, of the waypoint definition data for the first encoded waypoint of the procedure.
- r) *X coordinate* shall represent the X coordinate of a given waypoint in the coordinate system defined.
- s) *Y coordinate follows* shall indicate whether or not the Y coordinate is transmitted for a given waypoint. If the Y coordinate is not transmitted, the Y coordinate is assumed to be zero.
- t) *Y coordinate* shall represent the Y coordinate of a given waypoint in the coordinate system defined.
- u) *Z coordinate follows* shall indicate whether or not the Z coordinate is transmitted for a given waypoint.
- v) *Z coordinate* shall represent the Z coordinate of given waypoint in the coordinate system defined.

w) *Next segment/field identifier* shall indicate whether the next segment of a given procedure is straight or curved and indicate which data fields follow the waypoint coordinates.

x) *Threshold waypoint height* shall represent the height of the primary runway threshold waypoint above the runway threshold.

y) *Virtual azimuth to waypoint distance* shall represent the distance to the waypoint from the point to be considered as the origin for lateral guidance for an approach procedure not leading to the primary runway threshold.

Note.— This distance may be used by the MLS receiver in a manner similar to the approach azimuth antenna to threshold distance, to establish the lateral deviation scale factor for the procedure.

z) *Next waypoint index* shall represent the sequential position, within the approach azimuth database or back azimuth database, of the waypoint definition data for the next waypoint in the procedure.

Note.— The next waypoint index may be used to permit sharing of one or more waypoints which have been explicitly defined as a part of another procedure. The shared waypoints are the final ones for approach procedures and the initial ones for missed approach and departure procedures.

aa) *Missed approach index* shall represent the sequential position, within the approach azimuth database or back azimuth database, of the waypoint definition data for the first encoded (last flown) waypoint of the associated missed approach procedure.

Table A-14. MLS/RNAV procedure database structure
(see 3.11.4.8.3.2)

Database	Word	Data content
Approach azimuth	B1 B2	Approach azimuth map/CRC word
	...	Procedure 1 descriptor word
	... B(M+1)	...
	B(M+2) to B(a)	...
		Procedure “M” descriptor word (see Note 1) Waypoint data words
	B(a+1) to B(b-1)	Not used.
Back azimuth (see Note 2)	B(b)	Procedure 1 descriptor word

	B(b+N-1)	Procedure “N” descriptor word (see Note 1)
	B(b+N) to B(38)	Waypoint data words
	B39	Back azimuth map/CRC word

NOTES.—

1. Parameter “M” represents the number of named approach and departure procedures which commence within the approach azimuth coverage sector. Parameter “N” represents the number of named approach and departure procedures which commence within the back azimuth coverage sector.

A facility without a back azimuth database may employ all words up to B39 for the approach azimuth database.

Table A-15. Auxiliary data B words B1 through B39
(see 3.11.4.8.3.2)

Word	Data content	Type of data	Maximum time (seconds)	Bits used	Range of values	Bit numbers
Approach azimuth map/CRC word						
B1	PREAMBLE	digital	2.5	12		I ₁ to I ₁₂
	Address			8		I ₁₃ to I ₂₀
	Number of approach azimuth procedure descriptors			4	0 to 15	I ₂₁ to I ₂₄
	Last approach azimuth database word			6	see Note 2	I ₂₅ to I ₃₀
	Approach azimuth CRC code			32	see Note 3	I ₃₁ to I ₆₂
	Word B42 transmitted			1	see Note 4	I ₆₃
	Word A4 transmitted			1	see Note 4	I ₆₄
	Word B43 transmitted			1	see Note 4	I ₆₅
	Spare			4	see Note 12	I ₆₆ to I ₆₉
	PARITY			7	see Note 13	I ₇₀ to I ₇₆

Word	Data content	Type of data	Maximum time (seconds)	Bits used	Range of values	Bit numbers
------	--------------	--------------	------------------------	-----------	-----------------	-------------

Procedure descriptor words

B2 to B(M+1) (approach azimuth database) (see Note 1)
B(b) to B(b+N-1) (back azimuth database)

PREAMBLE	digital	2.5	12			I ₁ to I ₁₂
Address			8			I ₁₃ to I ₂₀
Basic indicator			25		see Note 5	I ₂₁ to I ₄₅
Validity indicator			4		1 to 9 (see Note 14)	I ₄₆ to I ₄₉
Route indicator			5		see Note 5	I ₅₀ to I ₅₄
Runway number			6		0 to 36 (see Note 15)	I ₅₅ to I ₆₀
Runway letter			2		see Note 6	I ₆₁ to I ₆₂
Procedure type			1		see Note 7	I ₆₃
First waypoint index			6		0 to 63 (see Notes 8, 9)	I ₆₄ to I ₆₉
PARITY			7		see Note 13	I ₇₀ to I ₇₆

Waypoint data words (see Table A-16)

B(M+2) to B(a) (approach azimuth database) (see Notes 1 and 11)
B(b+N) to B(38) (back azimuth database)

PREAMBLE	digital	2.5	12			I ₁ to I ₁₂
Address			8			I ₁₃ to I ₂₀

	Waypoint definition data items		49	see Notes 10, 11	I ₂₁ to I ₆₉
	PARITY		7	see Note 13	I ₇₀ to I ₇₆
Back azimuth map/CRC word (see Notes 1 and 11)					
B39	PREAMBLE	digital	2.5		I ₁ to I ₁₂
	Address				I ₁₃ to I ₂₀
	Number of back azimuth procedure descriptors		4	0 to 15	I ₂₁ to I ₂₄
	First back azimuth database word			see Note 2	I ₂₅ to I ₃₀
	Back azimuth CRC code			see Note 3	I ₃₁ to I ₆₂
	Word B43 transmitted			see Note 4	I ₆₃
	Spare			see Note 12	I ₆₄ to I ₆₈
	Back azimuth map/CRC indicator			see Note 11	I ₆₉
	PARITY			see Note 13	I ₇₀ to I ₇₆

NOTES.—

1. Variables used in word numbers correspond to those used in Table A-14.
2. This field is coded in accordance with Table A-9, using bits I₁₃ through I₁₈. In this table, bit I₂₅ carries the information of bit I₁₃ from Table A-9 and is transmitted first.
3. The CRC code contains the remainder, R(x), of the modulo 2 division of two polynomials:

$$\frac{x^{32} M(x)}{G(x)} \text{ mod } 2 = Q(x) + \frac{R(x)}{G(x)}$$

M(x) is the information field, which consists of the approach azimuth or back azimuth database defined below, excluding the preambles, addresses, parity bits, and CRC code bits. For auxiliary data words these are bits I₂₁ to I₆₉, and for basic data words bits I₁₃ to I₃₀. The database consists of the following data words in the order listed:

<i>Approach azimuth database:</i>	<i>Back azimuth database:</i>
B1 (bits I ₂₁ to I ₃₀ , I ₆₃ to I ₆₉)	B(b) to B38
B2 to B(a)	B39 (bits I ₂₁ to I ₃₀ , I ₆₃ to I ₆₉)
B40, B41	B40, B41, A3
A1 or B42, A2, A3	A4 or B43 (if transmitted)
A4 or B43 (if transmitted)	Basic data word 6
Basic data word 6	

M(x) is multiplied by x³², which appends 32 zero bits to the end of the dividend.

G(x) is the generator polynomial, defined as follows:

$$G(x) = x^{32} + x^{31} + x^{14} + x^{13} + x^9 + x^8 + x^4 + x^3 + x + 1$$

Q(x) is the quotient of the division.

The CRC code, R(x), is transmitted with the coefficient of x³¹ as bit I₃₁ and the coefficient of x⁰ as bit I₆₂.

4. The convention for coding is as follows:

- 0 = no
1 = yes
5. Alpha characters are coded as defined in 3.11.4.8.3 for data words B1 through B39.
6. The convention for coding is as follows:
0 = no letter
1 = R (right)
2 = C (centre)
3 = L (left)
7. The convention for coding is as follows:
0 = approach procedure
1 = departure procedure
8. Waypoint index numbers are assigned by sequentially numbering all waypoints in the approach azimuth or back azimuth database. If a waypoint at the primary runway threshold is coded using only a threshold crossing height, it is omitted from the waypoint index sequence.
9. A value of zero in this field indicates that the procedure is a computed centre line procedure based on data contained in auxiliary data words A1 (or B42), A2, A3 and A4 (or B43).
10. Waypoint definitions are of variable length and are coded sequentially without conforming to word boundaries. Spare bits are not permitted between waypoint definitions. Any spare bits at the end of the last waypoint data word are set to zero. Waypoint definitions for an approach procedure are coded in the order that the aircraft flies the procedure. Waypoint definitions for a missed approach or departure are coded in the reverse order. Missed approach or departure waypoints which are not shared with approach waypoints are coded after the last approach waypoint in the database.
11. A facility without a back azimuth data base may employ auxiliary word B39 as a waypoint data word for the approach azimuth database. Bit I₆₉ of word B39 is used to indicate the application of this word. The convention for coding is as follows:
0 = word B39 is a waypoint data word
1 = word B39 is the back azimuth map/CRC word
12. All spare bits are set to ZERO.
13. Parity bits I₇₀ to I₇₆ are chosen to satisfy the equations given in Note 1 of Table A-12.
14. The coded value 0000 is not allowed.
15. Runway number designation 0 is for heliport operations.

Table A-16. Waypoint definition data items
(see 3.11.4.8.3.2)

Data content	Bits used	Range of values	Least significant bit
X coordinate	15	±41 940 m (see Notes 1, 2)	2.56 m
Y coordinate follows	1	See Note 3	
Y coordinate	15	±41 940 m (see Notes 1, 2)	2.56 m
Z coordinate follows	1	See Note 3	
Z coordinate	13	-100 to +8 091 m (see Notes 1, 4)	1 m
Next segment/field identifier	3	See Note 5	
Threshold waypoint height	6	0 to 31.5 m (see Note 5)	0.5 m
Virtual azimuth to waypoint distance	6	0 to 6 300 m (see Note 5)	100 m
Next waypoint index	6	See Notes 5, 6	
Missed approach index	6	See Notes 5, 6	

NOTES.—

1. The origin of the coordinate system is the MLS datum point. The X-axis is horizontal, and lies in the vertical plane containing the runway centre line, with a positive number representing a location toward the approach reference datum. The Y-axis is horizontal and perpendicular to the X-axis, with a positive number representing a location to the left of centre line as viewed from the MLS datum point looking toward the approach reference datum. The Z-axis is vertical, with a positive number representing a location above the MLS datum point. Earth curvature is not considered when determining waypoint coordinate values.

2. The convention for coding is as follows:

Most significant bit is the sign bit:

0 = positive

1 = negative

The other bits represent the absolute value.

3. The convention for coding is as follows:

0 = no

1 = yes

The “Y coordinate follows” bit is set to ZERO (no) to indicate that the Y coordinate for the waypoint is zero. In this case, the Y coordinate field is not used. The “Z coordinate follows” bit is set to ZERO (no) to indicate either that the waypoint is two-dimensional or that it lies on a constant gradient between two waypoints for which the Z coordinate is transmitted. In either of these two cases, the Z coordinate field is not used.

4. This field is coded as an unsigned value with an offset of –100 m. A value of zero in this field would therefore represent a Z coordinate of –100 m.

5. Data fields which follow the next segment/field identifier are transmitted only for certain cases. The coding of the next segment/field identifier and use of subsequent data fields are defined in Table A-17.

6. Waypoint index numbers are assigned by sequentially numbering all waypoints in the approach azimuth or back azimuth database. If a waypoint at the primary runway threshold is coded using only a threshold crossing height, it is omitted from the waypoint index sequence. The next waypoint index field always refers to an index number lower than that of the current waypoint. The missed approach index field always refers to an index number higher than that of the current waypoint.

Table A-17. Next segment/field identifiers
(see 3.11.4.8.3.2)

Application				Next segment/ field identifier	Data field(s) to follow identifier		
Next waypoint location	Next waypoint shared (Note 1)	Linked to missed approach	Segment type		Approach procedure	Missed approach procedure	Departure procedure
Any	No	No	Straight	0	Next waypoint X coordinate		
			Curved	1			
	Yes		Straight	2	1. Next waypoint index 2. Next procedure first waypoint X coordinate		
			Curved	3			
Primary runway threshold	No	No	Straight	4	1. Threshold waypoint height 2. Next procedure first way- point X coordinate	Next procedure first waypoint X coordinate	
		Yes		5	1. Threshold waypoint height 2. Missed approach index 3. Next procedure first way- point X coordinate	Not allowed (see Note 3)	
None	No	No	None (see Note 2)	6	1. Virtual azimuth to waypoint distance 2. Next procedure first way- point X coordinate	Next procedure first waypoint X coordinate	
		Yes	Straight to first flown missed approach waypoint	7	1. Virtual azimuth to waypoint distance 2. Missed approach index 3. Next procedure first way- point X coordinate	Not allowed (see Note 3)	

NOTES.—

1. A shared waypoint is a waypoint that is identified in the current procedure by waypoint index number only. The waypoint coordinates are explicitly defined as part of another procedure.
2. Beyond this waypoint, guidance information is provided relative to the straight line extended from the current waypoint, tangent to the path entering the waypoint. In the case of a missed approach procedure, this line intersects the last approach waypoint.
3. Next segment/field identifier values 5 and 7 are reserved for use in approach procedures only. Missed approach and departure procedures may share approach waypoints which use these values, ignoring the data fields for threshold waypoint height, virtual azimuth to threshold distance and missed approach index.